

# Loop/AP Operation Manual

PRODUCT INFORMATION BULLETIN #2872

Record Platter System Identification Numbers Here:

Model # \_\_\_\_\_ Serial # \_\_\_\_\_

## TABLE OF CONTENTS

Safety Instructions.....	2
Non Loop Platter Operation.....	See AP Platter Operation Manual, #3001
Loop Make-Up (Through the Projector).....	3 & 4
Loop Run (Through the Projector).....	5 & 6
Loop Breakdown.....	6 & 7
Push Arm Lateral Adjustment.....	8
Pivot Arm and Push Arm Vertical Adjustment.....	9
Feed Castor Switch Adjustment....	See AP Platter Operation Manual, #3001
Pivot Motor Cam Limit Switch Check-Out Procedure.....	10
Pivot Motor Cam Limit Switch Adjustment.....	11&12
Make-Up Guide Adjustment.....	13
Loop Trouble Shooting & Maintenance.....	.....
.....	.....See AP Platter Operation Manual, #3001
Wire Schematics.....	14-17

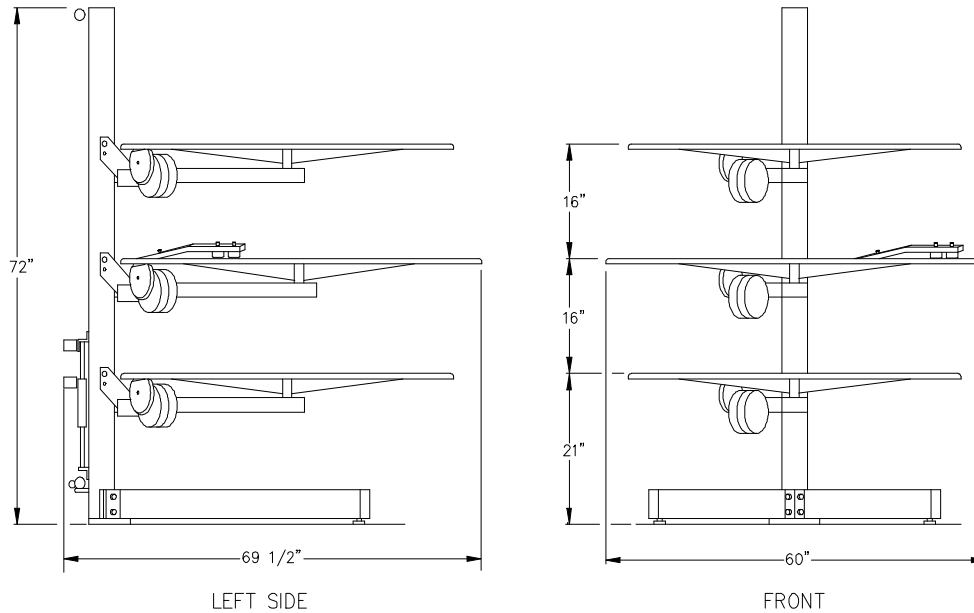

LOOP / AUTO PROGRAMMING PLATTER  
60" / 52" DIA. DISKS  
WEIGHT 400 POUNDS

NOTE: When using this Platter System as a non-loop system, refer to AP Platter Operation Manual #3001.

# IMPORTANT SAFETY INSTRUCTIONS

1. Read and understand all instructions before using.
2. Do not operate appliance with a damaged cord or if the appliance has been dropped or damaged-until it has been examined by a qualified serviceman.
3. Position the cord so that it will not be tripped over, pulled or contact hot surfaces.
4. If an extension cord is necessary, a cord with a current rating at least equal to that of the appliance should be used. Cords rated for less amperage than the appliance may overheat.
5. Always unplug appliance from electrical outlet before cleaning and servicing and when not in use. Never yank cord to pull plug from outlet. Grasp plug and pull to disconnect.
6. To reduce the risk of electric shock, do not use this product near water or other liquids.
7. To reduce the risk of electric shock, do not disassemble this appliance. Refer all work to a qualified serviceman when service or repair work is required. Incorrect reassembly can cause electric shock when the appliance is used subsequently.
8. The use of an accessory attachment not recommended by the manufacturer may cause a risk of fire, electric shock or injury to persons.
9. Connect this appliance to a grounded outlet.
10. Disconnect this unit from It's source of supply before replacing the lamps.

**SAVE THESE INSTRUCTIONS**

## POWER SOURCE

The Loop/Auto-Programming Platter System requires one 110/120 Volt AC, 50-60 Hz, 10 AMP grounded power outlet.

## FAILSAFE SYSTEM

The Loop/Auto-Programming Platter System is equipped with a built in Failsafe Switch. Any condition, such as film breakage, which allows the film Take-Up, located on the back of the column, to drop to the bottom of its travel will engage the Failsafe Switch, and power down the system

## NON LOOP PLATTER OPERATION

See Operation Manual for AP Platter System (#3001)

## PLATTER TO LOOP MAKE UP

(Through the Projector)

◆ When making up from the platter the table must be used to control the speed of the payout disk.

**Caution:** The Push Arm must be used when using Make Up Guides.

Never use the table as a speed control for the Loop Disk while the Push Arm is engaged.

1. Turn the power switch ON.
2. Turn the Loop Selector Switch to OFF.
3. Check to insure the Take-Up plate is at the bottom of its travel.
4. Make up the program onto one of the two non-loop platters. The threading diagram below shows the program starting on the bottom platter. Program Make-Up is explained in the Table operation manual.
5. Install the six Make-up Guides on the Loop Disk as shown in Figure 1.
6. Pull the Black Knobs until the Make Up Guides are fully extended.
7. Insure that the Push Arm is locked down and engaged with the disk cam.
8. Install the Loop Control Plate. (Make sure that the Take-Up plate is at the bottom or that the Loop drive motor is disengaged.)
9. Turn the Loop Selector Switch to LOOP RUN. Hold the Control Plate Arm clockwise. The Pivot Motor Cam and the Pivot Arm will rotate to its inward position and stop.

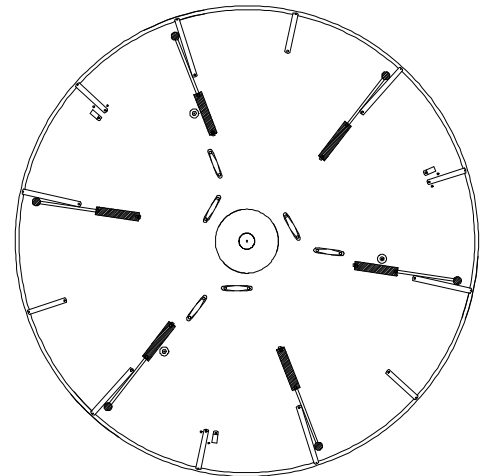

Figure 1

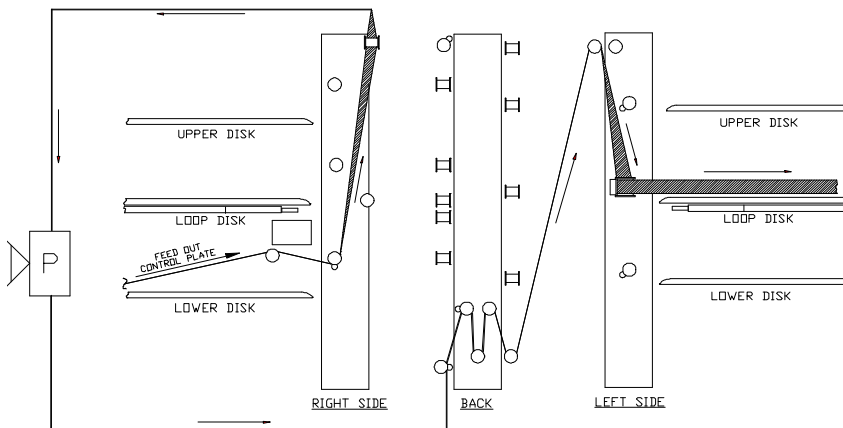

Figure 2

10. Remove the Loop Control Plate. This will insure that the Push Arm will remain at it's inward position. (NOTE: The program must be made up with the Push arm in the inward position.)
11. Turn the Loop Selector Switch to OFF.
12. Slowly rotate the disk by hand for two revolutions. The Push Arm Roller will contact the knobs on the Make Up Guides and set them to length.

13. Thread the film from the bottom disk to the loop disk as shown in Fig. 2, Page 3. Allow a sufficient length of film at the output of the projector to return to and make two revolutions around the Make-Up Guides.
14. Thread the film through the Take-Up to the Loop Disk. Wrap the film around one of the Make-Up Guide Knobs and tuck it under the rubber strip as shown in Fig. 3.
15. **Carefully** turn the disk by hand for the two revolutions, and **ease** the Take-Up to the top of its travel.
16. Turn the Loop Selector Switch to LOOP RUN.
17. Turn the table ON and, with the Pay-out Platter in Make-Up, adjust the speed control to remove the wraps of film around its control plate.
18. Turn the projector ON and adjust the speed of the payout platter with the Table Control for proper payout. The payout speed will have to be adjusted periodically as the film diameter changes.

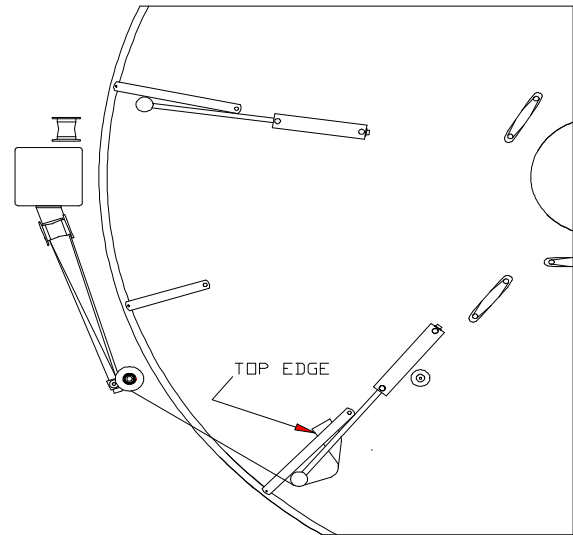

Figure 3

### TABLE TO LOOP MAKE UP

(Through the Projector)

◆ The table is only used to payout film, it should not be plugged into the table port on the Variac.

**Caution:** The Push Arm must be used when using Make Up Guides.

Never use the table as a speed control for the Loop Disk while the Push Arm is engaged.

1. Turn the Power Switch ON.
2. Turn the Loop Selector Switch to OFF.
3. Check to insure the Take-Up plate is at the bottom of its travel.
4. Place the program on the Table Make-Up Spindle (see Fig 4). The table will hold up to 17 3/4" diameter reels. Program Make-Up is explained in the Table operation manual.
5. Install the six Make-Up Guides on the Loop Disk as shown in Figure 1, page 3.
6. Pull the Black Knobs until the Make Up Guides are fully extended.
7. Insure that the Push Arm is locked down and engaged with the Disk Cam.
8. Install the Loop Control Plate (Make sure that the Take-Up plate is at the bottom or that the Loop drive motor is disengaged).

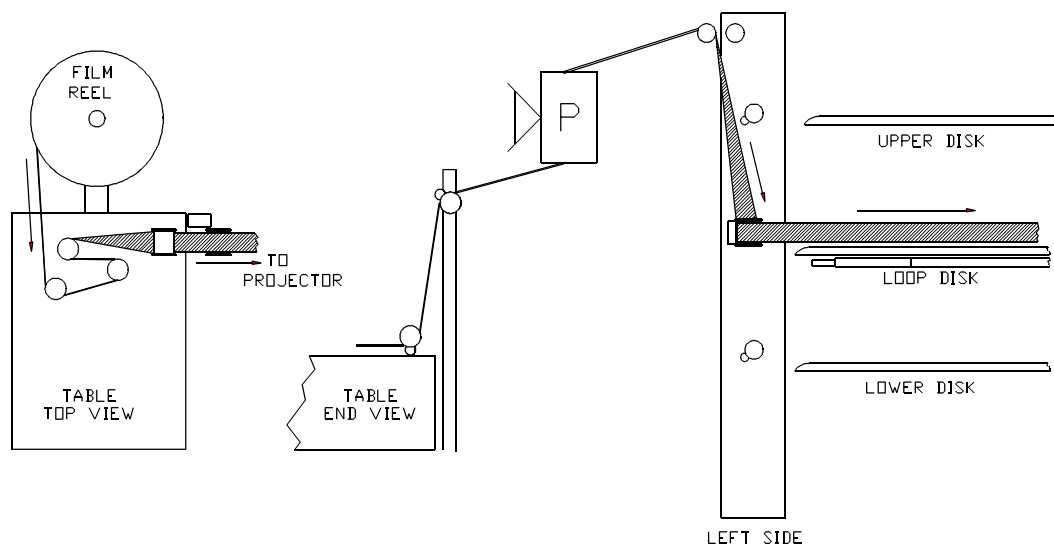

Figure 4

9. Turn the Loop Selector Switch to LOOP RUN. Hold the Control Plate Arm clockwise. The Pivot Motor Cam and Pivot Arm will rotate to it's inward position and stop.
10. Remove the Loop Control Plate. This will insure that the Push Arm will remain at it's inward position. (NOTE: The program must be made up with the Push Arm in the inward position.)
11. Turn the Loop Selector Switch to OFF.
12. Slowly rotate the disk by hand for the two revolutions. The Push Arm Roller will contact the knobs on the Make Up Guides and set them to length.
- 13.. Thread the film from the Table through the Projector to the Loop disk as shown in Fig. 4, Page 4. Allow a sufficient length of film at the output of the projector to return to and make two revolutions around the Make-Up Guides.
14. Thread the film through the Take-Up to the Loop Disk. Wrap the film around one of the Make-Up Guide knobs and tuck it under the rubber strip as shown in Figure 3, page 4.
15. *Carefully* turn the Loop Disk by hand for the two revolutions, and *ease* the Take-Up to the top of it's travel.
16. Turn the Loop Selector Switch to LOOP RUN.
17. Turn the projector ON.

### LOOP RUN

(Through the Projector)

1. Turn the Loop Selector Switch to OFF
2. Remove the six Make-Up Guides.
3. Install the Control Plate.
4. Insure that the Push Arm is locked down and engaged with the Disk Cam.
5. Thread the film from the Loop Control Plate through the Projector back to the Loop Disk (See Fig. 5). Allow a sufficient length of film at the output of the projector to return through the Take-Up to the outside edge of the Loop Disk as shown in Fig.6, Page 6.
6. Rotate the disk slowly by hand to eliminate the wraps of film around the Control Plate.

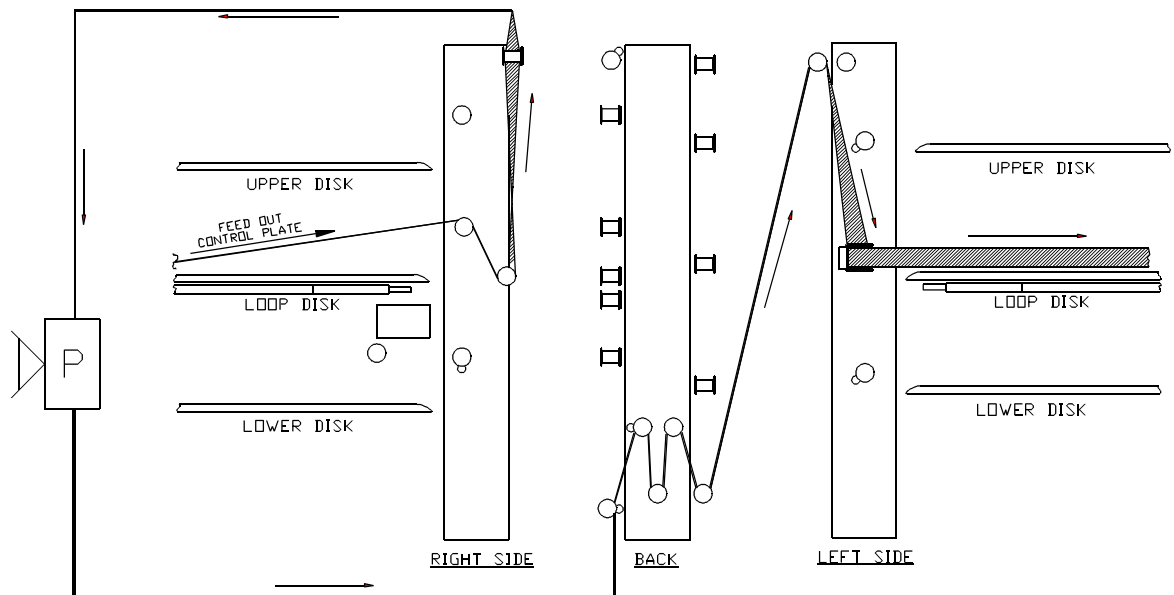

Figure 5

7. Remove all of the slack from the film path and rotate the disk until there is a 1/4 to 1/3 wrap of film around the Control Plate in the Counter Clockwise (CCW) direction.
8. Splice the two ends together. **Note:** Do not stretch the two ends of film to meet as this may cause cinching. It may be necessary to add or remove a little film to maintain the 1/4 to 1/3 film wrap.
9. **Carefully** rotate the loop disk by hand until the Take-Up eases to the top of its travel.
10. Turn the Loop Selector Switch to LOOP RUN.
11. The program is ready to show.

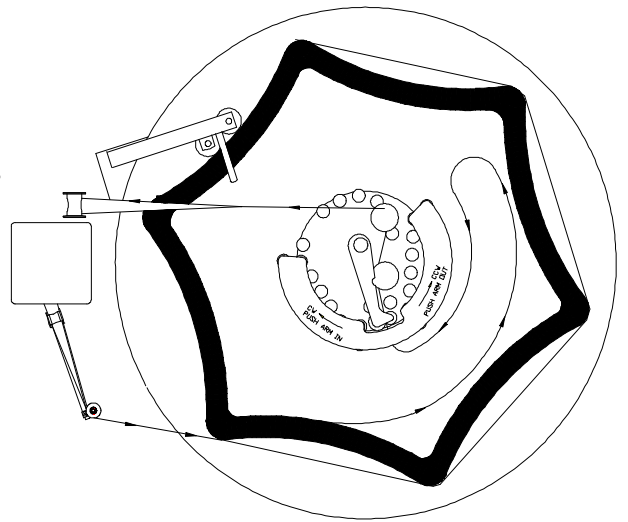

Figure 6

### BREAK DOWN

- ◆ There are two methods to break down a program from the Loop Platter:
  1. From the Loop Control Plate through the Projector back to a Non-Loop Platter, then breaking down the program as you would a normal platter. This is the recommended choice (shown in Fig. 7, Page 7).
  2. From the Loop Control Plate to the Table. This will put the film onto the reel head up (See Fig. 8, page 8).

### LOOP BREAK DOWN

(Through the Projector)

1. Turn the Loop Selector Switch to OFF.
2. Prior to the last showing of the program, cut the film at the beginning of reel #1.
3. Insure that the Push Arm is locked in its upward position and the Disk Cam Follower Roller is disengaged and locked.
4. Turn the Loop Selector Switch to BREAK DOWN. This allows the Loop Platter to function as a PAY-OUT Platter.
5. Raise the Take-Up Carriage and pin it in place. This will supply power to the Loop Platter and eliminate film wrap when threading the projector.
6. Thread the film from the Loop Control Plate through the Projector. Un-pin the Take-Up and thread to a Non Loop Platter.
7. The system is ready to run.

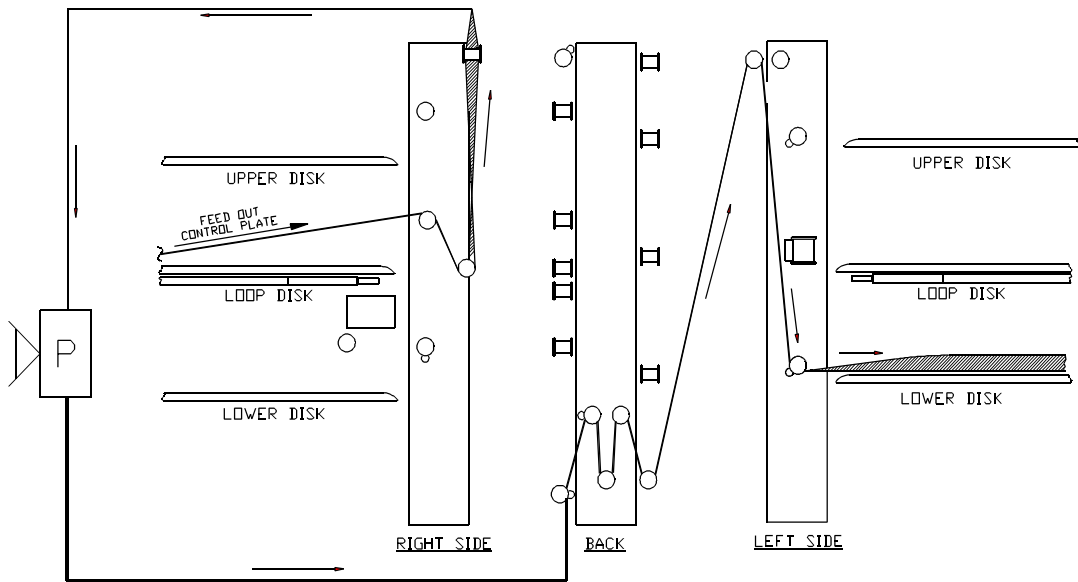

Figure 7

### **LOOP BREAK DOWN**

(To the Table)

1. Turn the Loop Selector Switch to OFF.
2. Prior to the last showing of the program, cut the film at the beginning of reel #1.
3. Insure that the Push Arm is locked in it's upward position, and the Disk Cam Follower Roller is disengaged and locked.
4. Turn the Loop Selector Switch to BREAK-DOWN. This allows the Loop Platter to function as a PAY-OUT Platter.
5. Raise the Take-Up Carriage and pin it in place. This will provide power to the Loop Platter
6. Thread the film from the Loop Control Plate to the Table Rewind Spindle (See fig. 8). Program BREAK DOWN can be found in the Table Operation Manual.
7. As the film is wound onto the Table, the Loop Control Plate will feed film from the center of the Loop Platter.

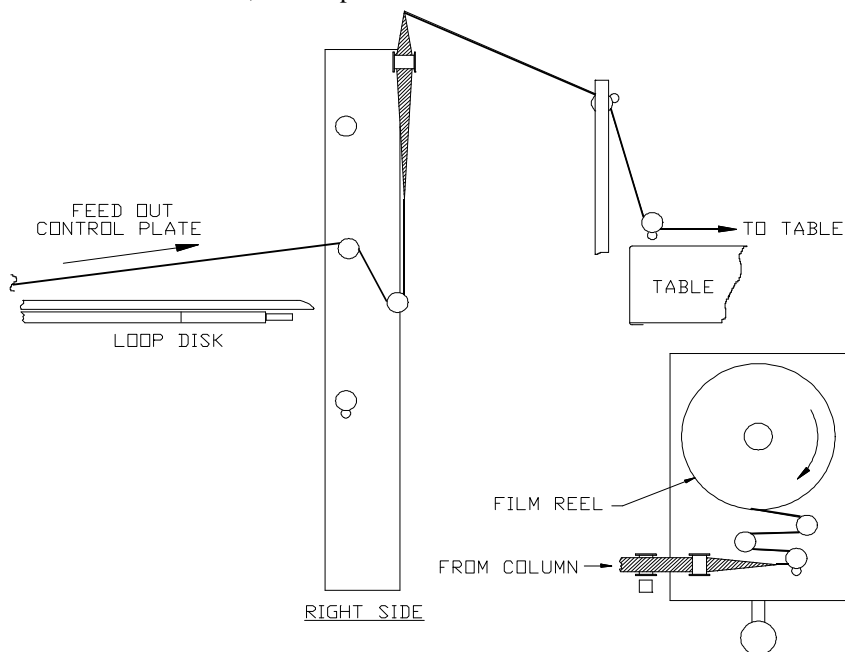

Figure 8

## PUSH ARM LATERAL ADJUSTMENT

◆ The Push Arm is adjusted at the factory, but should be checked when the system is installed to verify that proper alignment has not been affected during shipment.

1. Insure the Push Arm is locked down and engaged with the Disk Cam.
2. Install the Loop Control Plate and hold the Control Plate Arm Clockwise. The Pivot Motor Cam and Pivot Arm will rotate to it's inward position and stop.
3. Once the Pivot Motor Cam and Pivot Arm rotate inward and stop, turn the Loop Selector Switch to OFF. This will insure that the Push Arm will remain at it's inward position.
4. Rotate the Loop Disk CCW until the Push Arm Roller is located above adjustment holes (A) & (B) (See Fig. 9 below).
5. Fine tune the Loop Disk so that the end of the Push Arm Roller is on the edge or center of Hole (A). At this point the outside of the Push Arm Roller should be on the center of Hole (B) within plus or minus 1/16" (See Fig. 9). When checking this position, hold a small amount of outward pressure against the Push Arm.
6. Adjustments can be made by loosening the three bolts on the bottom side of the Push Arm Platform that hold the Push Arm in place.

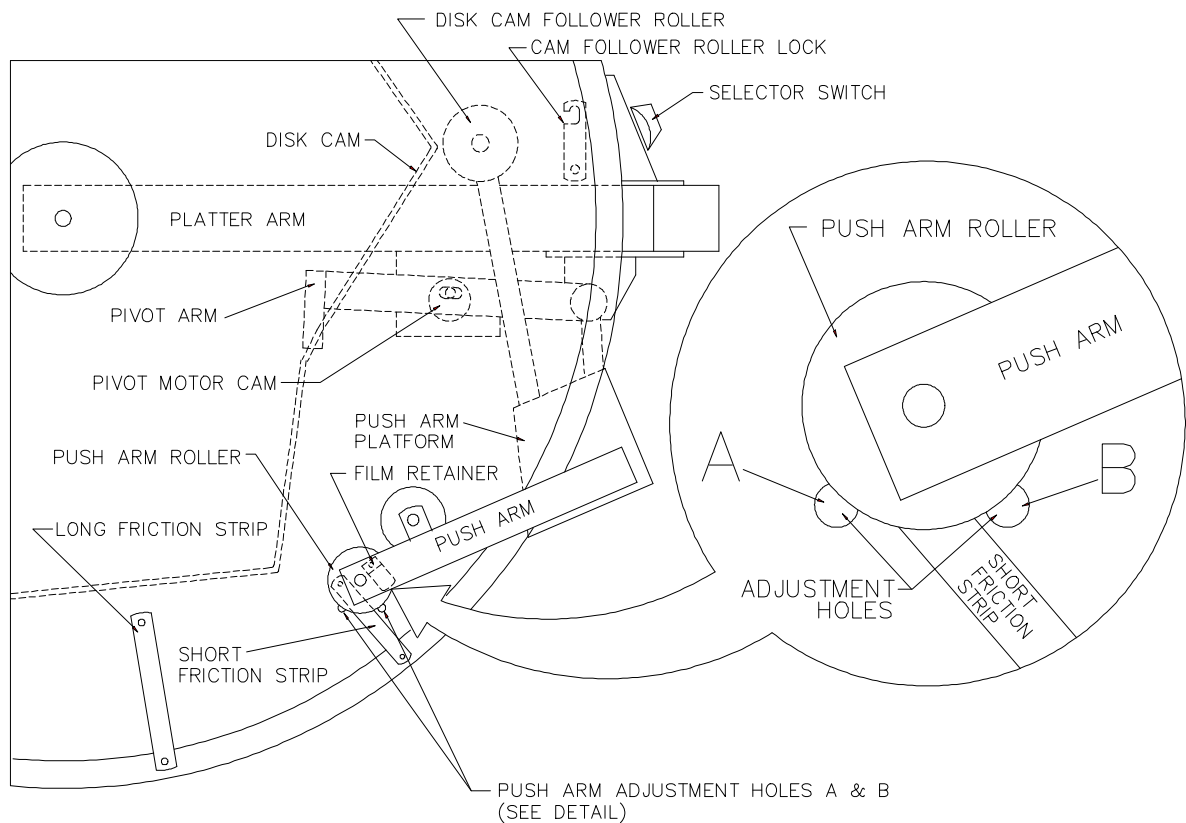

Figure 9

## PIVOT ARM AND PUSH ARM VERTICAL ADJUSTMENT

1. Locate the top of the Pivot Arm so it is parallel to the Loop Arm. There should be a 3/32" (2.4mm) gap between the bottom of the Pivot Arm and the top of the Pivot Motor Cam (See Fig. 10).
2. Insure that the Push Arm is locked in it's upward position and the Disk Cam Follower Roller is disengaged and locked.

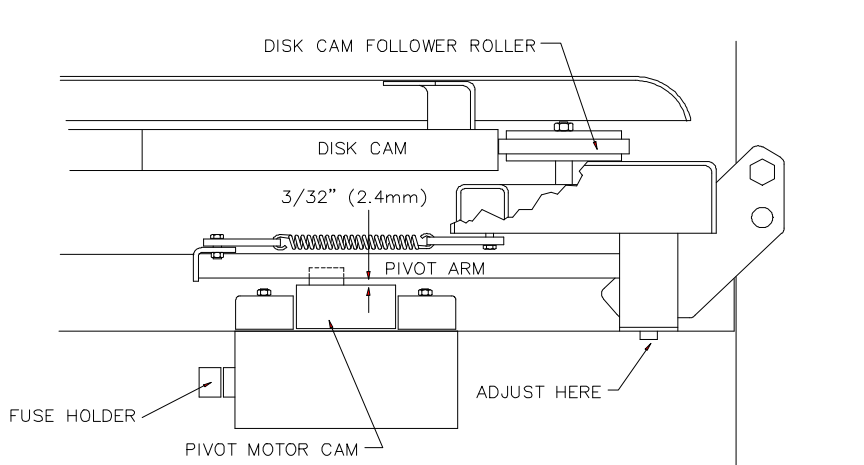

Figure 10

3. Disengage the Loop Drive Motor and install the Loop Disk.
4. Unlock the Disk Cam Follower Roller and engage the Drive Motor.  
*NOTE:* The drive motor must be engaged when making the Push Arm adjustments.
5. Make sure the Disk Cam Follower Roller is riding on the Disk Cam as shown in Fig. 9 and Fig. 10. Adjust using the two bolts securing the arm to the Push Arm Platform (See Fig. 11).
6. Lower and lock the Push Arm. Set the height of the Spanker Bar to the height of the film plus 1/8" (3mm). (See Fig. 11). This is done by adjusting the Spherical Head Bolt which supports the Push Arm (See Fig. 11). Use a small roll of film as a gauge.
7. Set the height of the Push Arm Rollers for minimum clearance above the Rubber Friction Strips and the three Film Retainers. The Push Arm Rollers can be adjusted by loosening the Set Screws clamping the Roller Shaft, adjusting the Roller and retightening the Set Screw (See Fig. 11).
8. Recheck the Push Arm lateral adjustment (See Fig. 9, page 8).

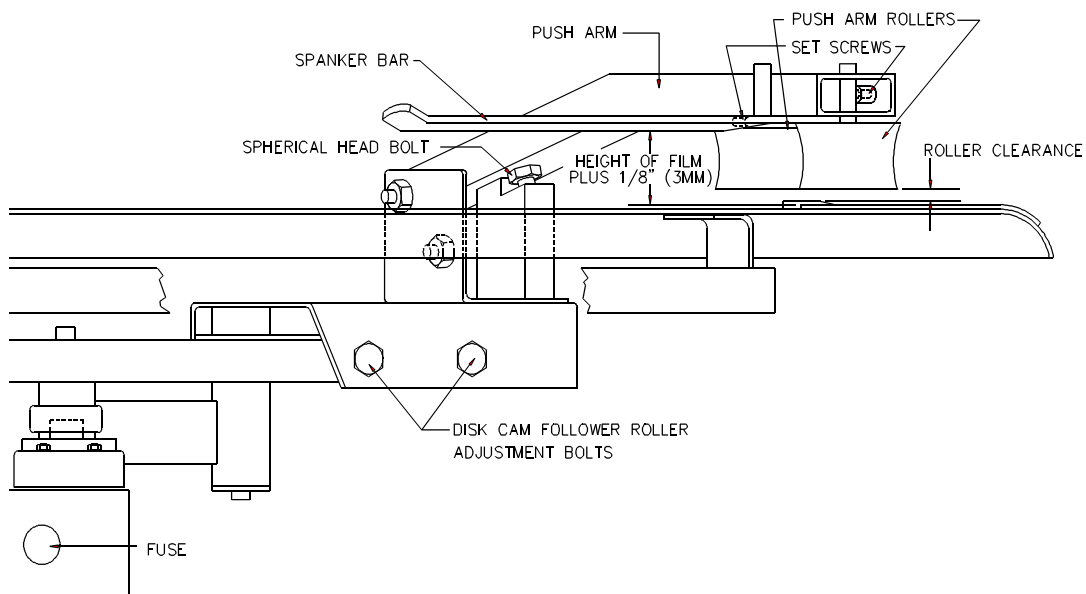

FIGURE 11

## MOTOR HEIGHT ADJUSTMENT

See Operation Manual for AP Platter System #3001

## FEED CASTOR SWITCH ADJUSTMENT

See Operation Manual for AP Platter System #3001

## FAILSAFE SWITCH ADJUSTMENT

See Operation Manual for AP Platter System #3001

## PIVOT MOTOR CAM LIMIT SWITCH CHECK-OUT PROCEDURE

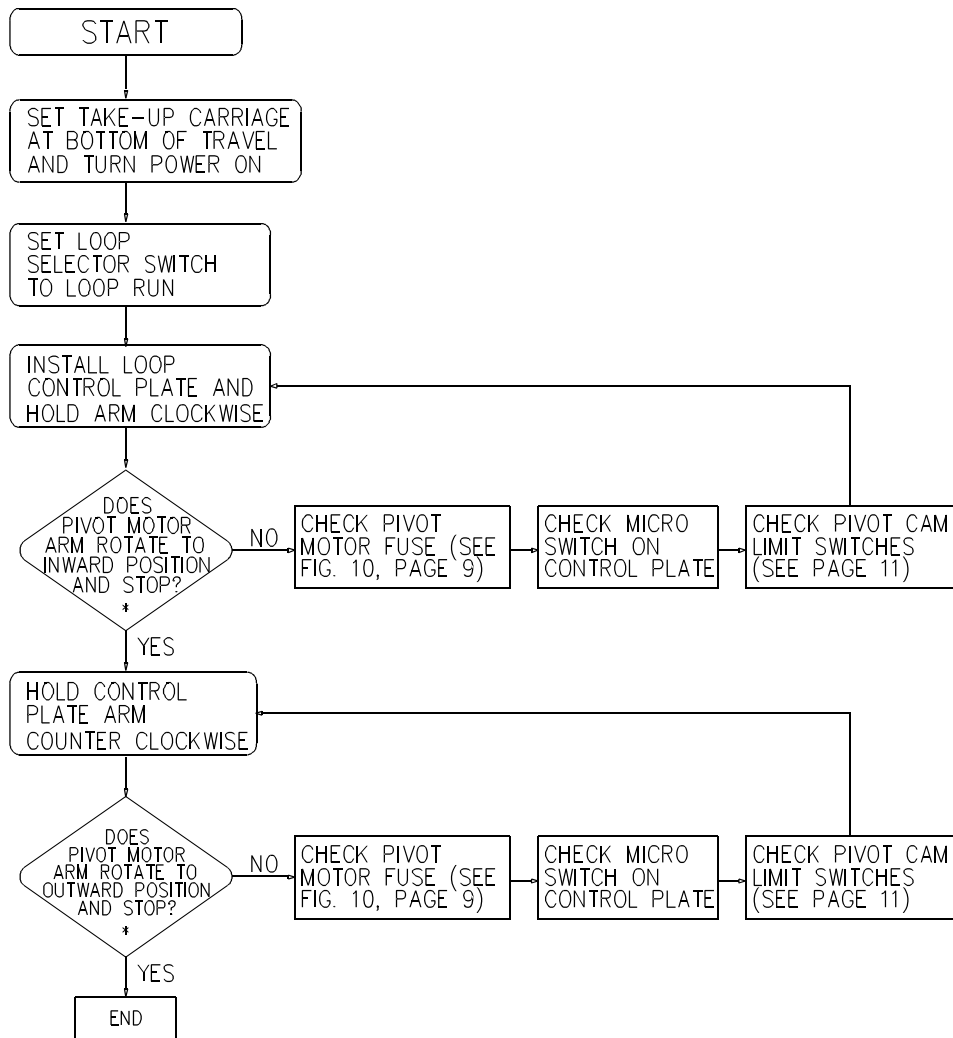

\* THE MOTOR WILL REQUIRE APPROXIMATELY 15 SECONDS TO MOVE THE ARM FROM FULLY IN TO FULLY OUT OR FROM FULLY OUT TO FULLY IN.

## PIVOT MOTOR CAM LIMIT SWITCH ADJUSTMENT

1. Disengage the Drive Motor and turn the Loop Selector Switch to LOOP RUN.
2. Install the Loop Control Plate and hold the Control Plate Arm Clockwise (CW). The Pivot Motor Cam and Pivot Arm will rotate to it's inward position and stop.
3. Hold the Loop Control Plate Arm Counter Clockwise (CCW). The Pivot Motor Cam and Pivot Arm will rotate to it's outward position and stop.
4. If the Pivot Motor Cam fails to rotate and stop in either direction, the Loop will not run correctly and the following should be checked:
  - A. Check the Pivot Motor Cam Fuse, 1 ½ amp, 250 vac located in the front of the Pivot Motor Cam Box (See Fig. 10, page 9).
  - B. Remove the Loop Control Plate and check the micro switch with an ohm meter to verify that the NORMALLY OPEN (NO) and NORMALLY CLOSED (NC) contacts are working correctly. When the Loop Control Plate Arm is clockwise (CW), the NO and Common Contacts are made. When the Loop Control Plate Arm is Counter Clockwise (CCW) the NC and Common Contacts are made.
  - C. The Pivot Motor Cam Limit Switches are shown in Fig. 12. The micro switch on the right stops the Pivot Motor Cam when it rotates to the it's inward position and the micro switch on the Left stops the Pivot Motor Cam when it rotates to it's outward position. The Normally Open (NO) Contact of the micro switch is open when the Cam Limit Switch is in the detent, and Closed when the switch is out of the detent.

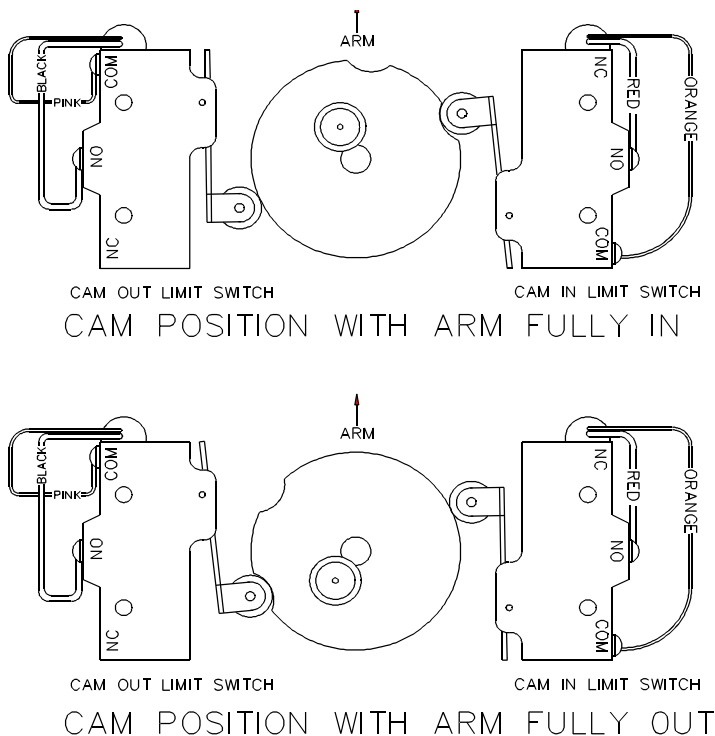

Figure 12

5. To check the Pivot Motor Cam Limit Switches:
  - A. Turn the power switch OFF and unplug the power supply.
  - B. Insure that the Push Arm is locked in it's upward position (See Fig. 13) and the Disk Cam Follower Roller is disengaged and locked (See Fig. 9).
  - C. Disengage the Loop Drive Motor and remove the Loop Disk.

- D. After the Loop Disk is removed, disengage the Disk Cam Follower Roller Lock. Remove the two Socket Head Cap Screws which hold the Pivot Arm Shaft to the Loop Arm Mount Bracket. You will now be able to remove the Pivot Arm, Push Arm Platform and Disk Cam Follower Assembly (See Fig. 13). A 1/4" Hex Allen Wrench will be required to remove the capscrews.
- E. Remove the Limit Switch Covers. Loosen the Set Screw in the Pivot Motor Cam to allow the Cam to be rotated on the Cam Motor Shaft. A 1/8" Hex Allen Wrench is required. If the set screw is not accessible, plug in the Power Supply, turn the power switch to ON and turn the Loop Selector Switch to LOOP RUN. **CAUTION!** The Pivot Motor Cam Limit Switches will have 115 vac present at this time. Install the Loop Control Plate and move the Control Plate Arm until the Pivot Motor Cam set screw is accessible (See Fig. 13). Turn the power switch OFF and unplug the power supply.

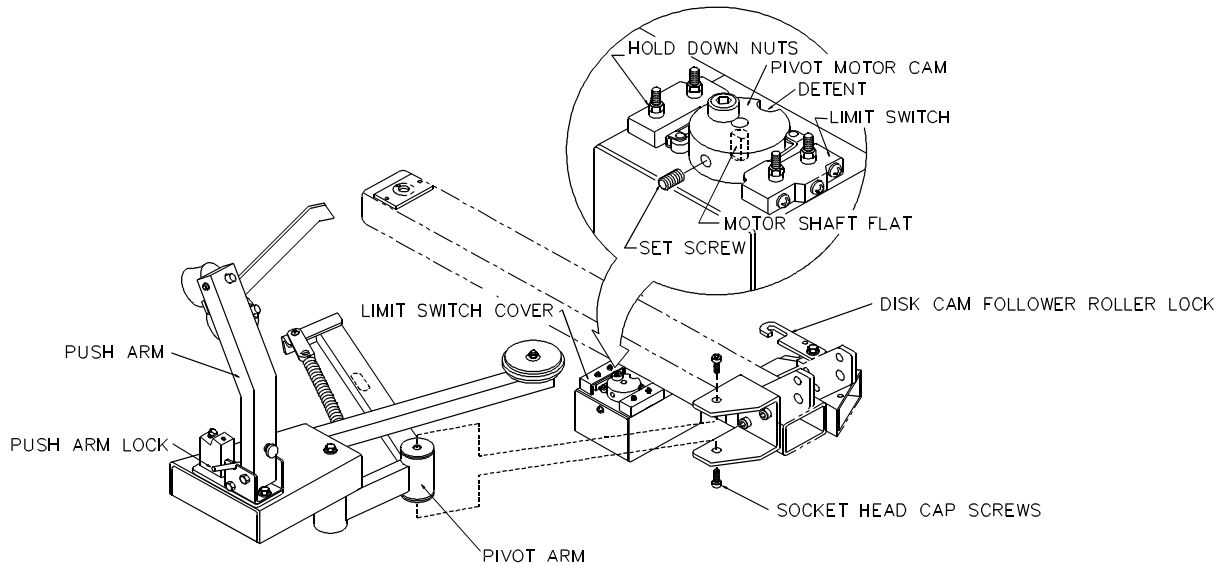

Figure 13

- F. Once the Pivot Motor Cam is free, rotate the Cam and allow the Limit Switch to engage the detent. You should hear an audible click when the switch drops into the detent and again when it comes out of the detent. If a click is not heard, loosen the two hold down nuts and adjust the switch until the clicks can be detected. The switch is adjusted correctly when there is a small amount of Limit Switch Arm travel after the audible click. When going into the detent the Limit Switch should be adjusted so that the audible click occurs before the Limit Switch Arm Roller is at the bottom of the detent. When coming out the audible click should occur before the Limit Switch Arm Roller is out of the detent.
6. After the Pivot Motor Cam Limit Switches are adjusted, make sure the cam is seated completely on the Motor Shaft and reinstall the Set Screw so it is against the flat on the shaft. Replace the switch covers and plug in the power supply. Turn the power switch to ON and turn the Loop Selector Switch to LOOP RUN. Install the Loop Control Plate and repeat steps 2 and 3. Reinstall the Pivot Arm, Push Arm Platform and Disk Cam Follower Assembly and secure with the Socket Head Cap Screws which hold the Pivot Arm Shaft to the Loop Arm Mount Bracket (See Fig. 13).
  7. See the Pivot Arm Vertical Adjustment Instructions before reinstalling the Disk.

## **MAKE-UP GUIDE ADJUSTMENT**

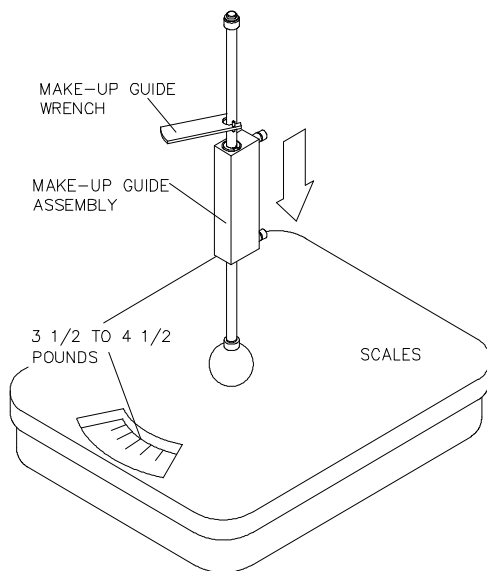
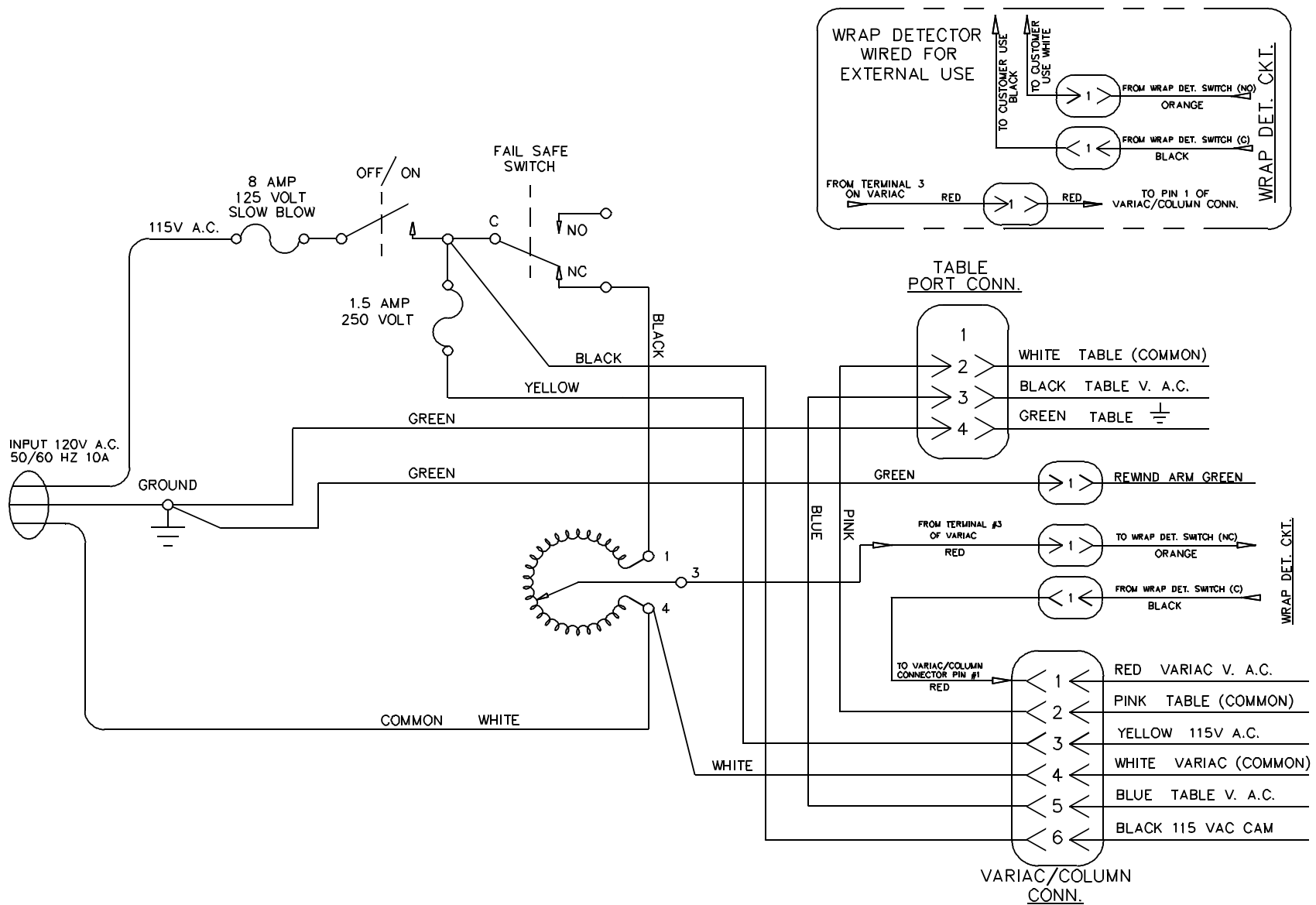

Figure 14

- 1) Remove one Make-Up Guide from the Loop Disk and slide the Guide Block to the E-ring end.
- 2) Place the ball end of the Make-Up Guide on a set of scales and push the Guide Block downward on the shaft. The scales should measure  $3 \frac{1}{2}$  to  $4 \frac{1}{2}$  pounds before the Guide Block begins to move on the shaft. If the scales measure less than  $3 \frac{1}{2}$  pounds, tighten the Tension Adjustment Screw using the Make-Up Guide Wrench supplied. If more than  $4 \frac{1}{2}$  pounds of pressure is required, loosen the screw.
- 3) Repeat the process with the remaining Guides.

## **TROUBLE SHOOTING and MAINTENANCE**

See Operation Manual for AP Platter System #3001



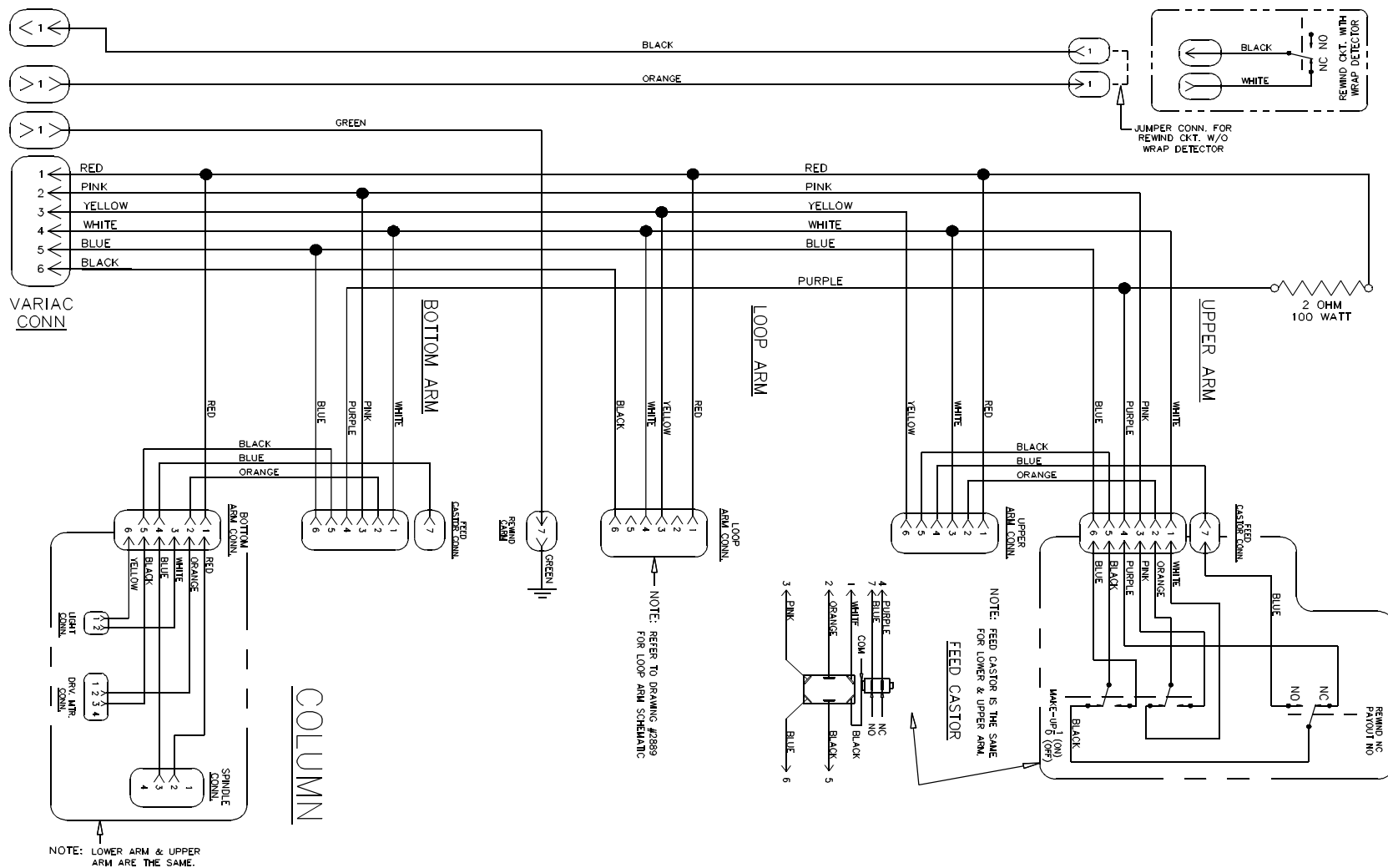

LOOP/AP COLUMN/ARM WIRE SCHEMATIC

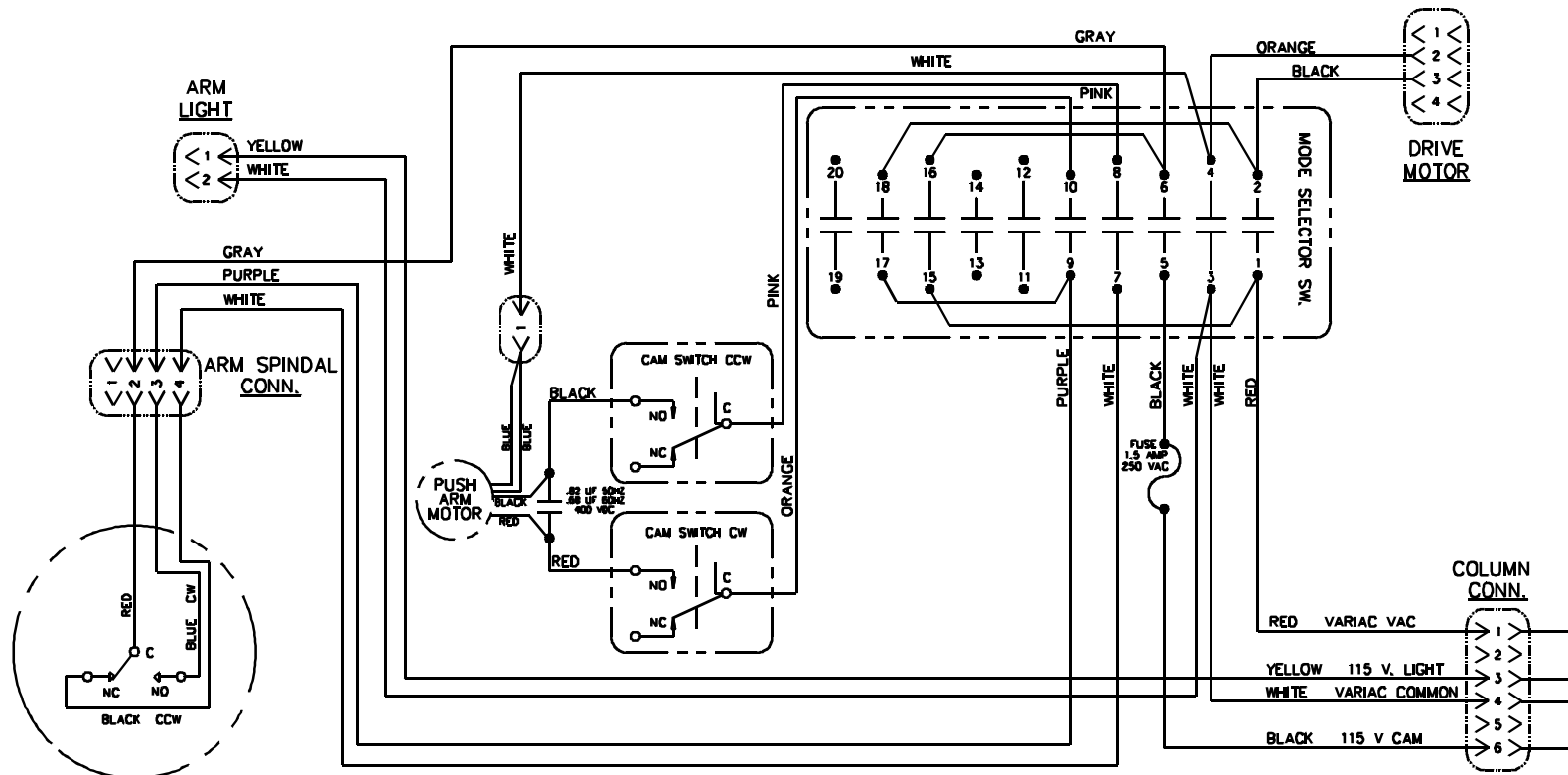

LOOP CONTROL PLATE SWITCH

<u>SELECTOR SWITCH</u>	
POSITION	CONTACTS
1. OFF	
2. LOOP-RUN	1-2,3-4,5-6,7-8,9-10
3. MAKE-UP	NOT USED
4. BREAK DOWN	3-4,15-16,17-18

LOOP/AP MODE SELECTOR SWITCH/LOOP ARM WIRE SCHEMATIC

NON LOOP  
CONTROL PLATE  
PHASE CONTROL

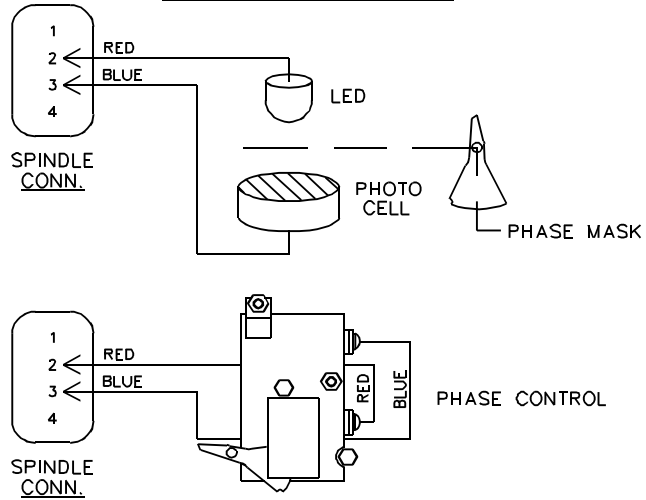

NON LOOP  
CONTROL PLATE  
MICRO SWITCH

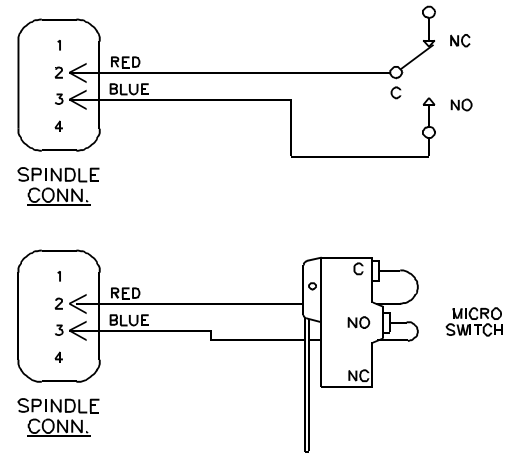

DRIVE MOTOR A.P.

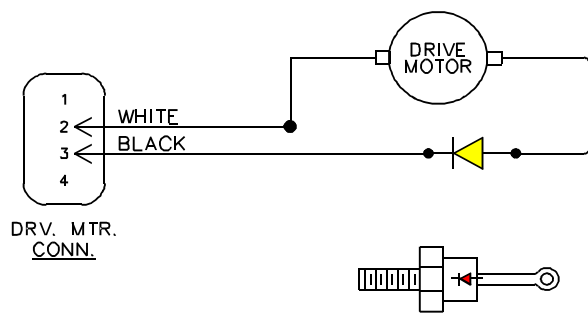

ARM LAMP

