

CNA-100 Cinema Network Automation

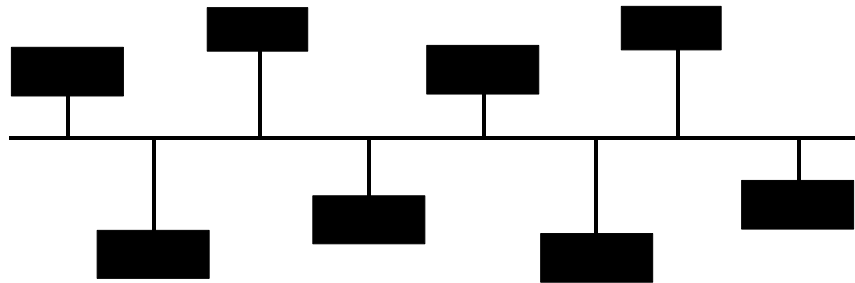

Operation and Installation Reference Manual



BALLANTYNE OF OMAHA

March 1999

WARRANTY INFORMATION

The CNA-100 Cinema Network Automation, sold by STRONG INTERNATIONAL, is warranted against defects in materials and workmanship for one year from the date of purchase. There are no other express or implied warranties and no warranty of merchantability or fitness for a particular purpose.

During the warranty period, STRONG INTERNATIONAL will repair or, at its option, replace components that prove to be defective, provided the unit is shipped prepaid to the manufacturer directly or via an authorized distributor. Not covered by this warranty are defects caused by modification, misuse or accidents and any further damage caused by inadequate packing for service return.

STRONG INTERNATIONAL's obligation is restricted to the repair or replacement of defective parts and under no circumstances will STRONG INTERNATIONAL be liable for any other damage, either direct or consequential.

Information in this document is subject to change without notice. No part of this document may be reproduced or transmitted in any form or by any means, electronic or mechanical, for any purpose, without the express written permission of STRONG INTERNATIONAL.

© 1997 - 1999 STRONG INTERNATIONAL. All rights reserved.

An Introduction to
THE CINENET™ SYSTEM

Strong International's CINENET™ is an automation and control network designed specifically for the Motion Picture Theatre Industry. CINENET™ provides a low cost connection to various control and I/O devices in the projection booth, auditorium, and throughout the theatre complex. CINENET™ is divided into two network layers: The Local Synchronous Network (LSN) is a complex-wide data network that provides advanced synchronous projector control, user selected data transfer and real-time remote automation status. The Local I/O Network (LIN) is designed to provide remote I/O control for each screen in a complex. The CINENET™ network offers many advantages over point-to-point wiring such as reduced installation costs, reduced wiring errors and high noise immunity. CINENET™ also allows management to program and access real-time status of all auditoriums in the theatre complex from a central location using a personal computer. Strong will continue to develop new CINENET™ products that will provide the control and flexibility the theatre industry demands.

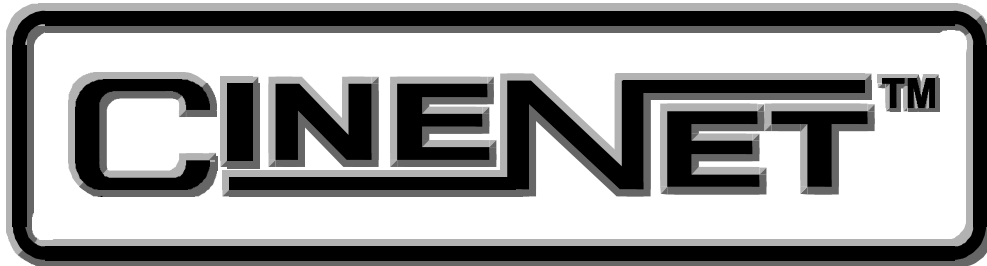

Section 1

SYSTEM OVERVIEW

The CNA-100[®] Cinema Network Automation is a CINENET[™] compatible automation system specifically designed for the Motion Picture Theatre industry. The system is modular in design, consisting of the operator interface and system peripherals. The Main Computer and each peripheral device is defined by its common functions and locations in the booth. The devices within the system communicate with each other on a serial communications link. Automation systems and remote stations distributed throughout the booth and other areas of the multiplex communicate on a second serial communications link.

The CNA-100 operator interface is user friendly and self-intuitive. Once some basic rules are learned you will be programming and running basic programs in less than an hour.

To enhance the operation of the CNA-100 and provide a higher level of control, the CINENET[™] Gateway PC Card and Host software is available. This product will provide a PC interface to the CNA-100 automations. The Host PC and software will allow management to access programming, data logging and diagnostic information from all systems connected to the network. Access to data and system upgrade software will also be available via the modem/Internet.

This manual provides the installer and user with the necessary information to install, setup and operate the CNA-100 automation system. The installer is encouraged to read all sections of the manual before proceeding with the installation. If while installing or operating the CNA-100 automation you find any part of the manual to be unclear or incorrect, please let us know. Call STRONG INTERNATIONAL at (800)-424-1215 if help or additional information is required.

Product Description

The CNA-100 Cinema Network Automation System is a microprocessor based computer automation designed to automate all aspects of the theatre presentation. The major features of the CNA-100 are listed below.

Local I/O Network (LIN)

Each system component is connected to the network and communicates via a five wire cable. This cable provides the serial communications as well as power to the termination panels. This is called the "Local I/O Network" or "LIN". The standard devices that make up the system are the:

1. Console Termination Panel
2. Booth Termination Panel
3. CNA-100 Control Panel

The CNA-100 Automation Control Panel contains the Main or Master Computer of the system and each I/O device is connected to it via a serial communications link. The devices are connected in a "daisy-chain" method and can then be distributed within the booth according to their logical location.

Local Synchronous Network (LSN)

The "Local Synchronous Network" is a two-wire data link that will support CNA-100 and CNA-200 Automations, remote stations, synchronous communications for interlock, network copy functions and a Host PC. The automation systems are connected together in a "daisy-chain" configuration, which allows the transmission line to continue from one unit to the next.

System Components

The standard components that make up the automation system LIN are described in the following sections.

Control Panel (Operator Interface)

The automation controller and front panel interface is a self-contained unit that can either be surface mounted to the booth wall or can be mounted in a standard 19" rack. The unit will house the main CPU, the front panel interface and the power supply for local and remote power for the Local I/O Network.

Communications to the local I/O devices and other remote CNA-100 systems is accomplished via two serial ports on the Main CPU:

The Local I/O Network (LIN) Com Port - This is the interface for the Local I/O Network that will support the Main I/O Interface, the Console and Booth Termination Panels and other auxiliary devices.

The Local Synchronous Network (LSN) Com port - This is the interface for the Interlock and Copy function between CNA-100 systems, Remote Monitors and PC Host.

The front panel is used to setup, program and run the shows. It also displays error and status messages to the user. The front panel incorporates up to nine manual override switches used for emergency manual control. These are rocker type switches and their general functions should be obvious to the operator. All manual controls circumvent the electronic circuitry giving the user the ability to control the major functions in the event of an automation failure. The manual control functions are listed below:

1. PROJECTOR - Maintained ON/AUTO
2. LAMP - Maintained
3. CHANGEOVER - Momentary OPEN/CLOSE
4. LENS - Momentary FLAT/SCOPE
5. LENS - Momentary SPECIAL
6. CURTAIN - Momentary OPEN/CLOSE
7. HOUSE LIGHTS - Momentary UP/DOWN
8. STAGE LIGHTS - Momentary UP/DOWN
9. AUXILIARY - Momentary ON1/ON2

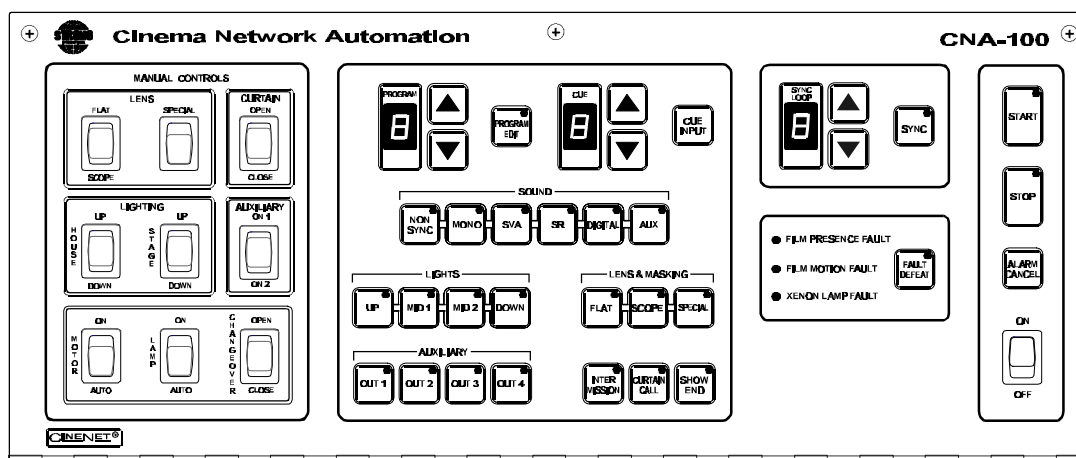

Figure 1.1

Program Number

Displays the program number to run or edit. Use the up and down cursor keys to select the program number. Up to nine unique programs can be saved.

Cue Number

Displays the show cue number. During programming use the up and down cursor keys to select the cue number to edit. Up to nine cues can be programmed for a show.

Programming Keys

These keys are used to program the sound, lens, masking, lights, intermission, curtain call and end of show. LEDs are on each key. The LED is "on" indicating the present state of the output during a show.

Program Edit Key

This key is used to enter the program edit mode allowing the user to build new or alter existing programs. The LED is on when "program edit" is active. The user may edit any program during a show or between shows.

Start Key

This key is used to start or restart a show. The LED on the start key will "blink" when the show is *ready to start* or *ready to restart*. The LED is "on" when the show is running, and "off" when the show is stopped.

Stop Key

This key is used to stop a show. The LED on the stop switch is "on" when a show is stopped, due either to a "local" or "remote" stop input or a fault.

Sync Key

This key is used to activate the automation for synchronous (interlock) operation. The sync LED will be "on" indicating the automation is in sync mode.

Sync Loop Number

This displays the Sync Loop number. Use the up and down cursor keys to change the loop number. Up to 9 different loops can be on the sync network. 0 disables the machine from sync operation. The user is prevented from changing the Sync Loop number when sync is enabled with the Sync Key.

Fault Status LEDs

These LEDs display the status of the fault conditions: *Film Presence*, *Film Motion* and *Xenon Fault*. The LEDs are "off" when there is no fault present. When a fault exists, the LED will "blink" rapidly.

Power Switch

Supplies power to the automation main controller and termination panels.

Fault Defeat Key

This key will defeat or bypass the fault inputs (film presence, film motion and xenon lamp). This key is normally used for testing the projection equipment or newly edited programs. It is *not* recommended for normal operation. The LED will "blink" when the Fault Defeat is activated.

Alarm Cancel Key

This key will cancel the local alarm and all remote alarms. This key is also used to clear any of the latched faults. Pressing the Alarm Cancel key once will cancel the alarm. Pressing the key again will clear the fault condition.

Cue Input Key

This key provides a manual cue input. This is similar to the cue input from the electronic cue detector or pick off. This key is always active during a show.

Console Termination Panel

This panel supports the input and output termination interface and provides connections for standard booth functions as listed below:

Outputs:

- Projector Motor; On/Off
- Xenon Lamp; On/Off
- Changeover; Open/Close
- Lens Turret; Flat/Scope/Special
- Auxiliary Output; On/Off

Inputs:

- Film Presence
- Film Motion
- Film Tension
- Cue Input
- Xenon Fault

Features:

- High power *dry* relay contact outputs.
- High power override connector for plug-in cable to override switches.
- Projector motor fuse.
- Plug-in I/O CPU Control Board to handle I/O and serial interface.
- Terminal Blocks for connection to the console equipment.

The relays and I/O CPU Control Board get their power from the network cable. The Control Board will plug onto the relay board to provide the I/O and network interface.

Booth Termination Panel.

This panel provides the outputs to control the following functions:

Outputs:

- Top Masking; Flat/Scope/Special
- Side Masking; Flat/Scope/Special
- Curtains; Open/Close
- House Lights; Up, Down, Mid 1, Mid 2
- Stage Lights; Up, Down
- Environment; On/Off
- Slide Projector; On/Off
- Sound Processor; Mono, SVA, SR, Digital 1, Aux, Nonsync

Inputs:

- Remote Start
- Remote Stop

Features:

- Low power dry relay contact outputs.
- High power dry relay contact outputs for Slide Projector and Environment Control
- A plug-in I/O CPU Control Board to handle I/O and serial interface.
- Override connector for plug-in cable to override switches.
- Override connector for optional override switches.
- Large terminal blocks for user interface.

This Panel (PC board) will connect to the to the Local I/O Network (LIN). The outputs can be configured at the PC Host.

The relays and plug-in I/O CPU Control Board get their power from the LIN cable. This board will generally be mounted in a cabinet on the booth wall, but can also be mounted in the console next to the Booth Termination Panel.

Section 2

INSTALLATION

The Installation section of this manual provides detailed wiring diagrams to aid in the installation process. A special section entitled *Installation Guidelines* is included to provide the installer with a set of important rules to follow that will help insure a successful installation.

Equipment Required

The CNA-100 should be installed only by an electrician, engineer or other qualified personnel. No special equipment or tools are required for installation. Typically the CNA-100 main controller and Console termination panel will be mounted in the Strong console and factory pre-wired.

Equipment Inspection

The equipment should be carefully inspected for signs of visible damage resulting from transportation and handling. Please notify the freight carrier immediately if damage is found.

Wiring the CNA-100 System

Remember, during installation to insure that all requirements of national and local electric codes are satisfied. Be sure to run *clean* power (dedicated to the CNA-100 systems only) to all CNA-100 automation systems from the service entrance panel or closest branch panel. The line, neutral and ground wires should all run back to the main service panel (separate from all other loads). It is acceptable and preferred if all automations were run from a single distribution point.

Important Note: Do not connect the projector motors, changeovers, xenon rectifiers or other heavy or noisy loads to this circuit.

Before applying power, verify that the power supply inside the unit is set to the same voltage (120V or 230V) that will be powering the unit. If it is not, move the switch S1 to the appropriate position. To access the power supply, open the front panel by removing the three screws along the top-front of the unit. The power supply board is mounted to the back wall. The switch S1 can be set with a small *flat-blade* screwdriver. Figure 2.1 shows the power supply power terminations and voltage selectors switch.

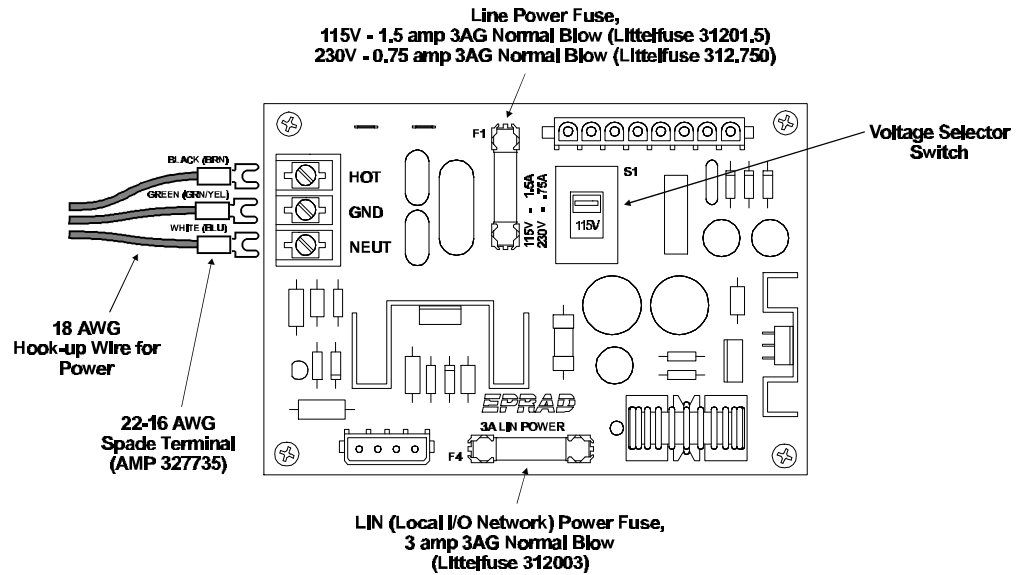

Figure 2.1

There are also two field-replaceable fuses on the power supply board. F1 is the line power fuse and F4 is the LIN (Local I/O Network) power fuse. All units are shipped from the factory with a 1.5 amp line fuse (F1). If 230 volt ac operation is required, it is the responsibility of the installer to change this to a 0.75 amp fuse. (Littelfuse #312.750). Remember, before servicing these fuses, be sure power is removed from the unit.

Wiring between the CNA-100 automations and system peripherals are shown in figure 2.2. The wiring between the components and systems are accomplished with two communication networks. These are the LIN and LSN.

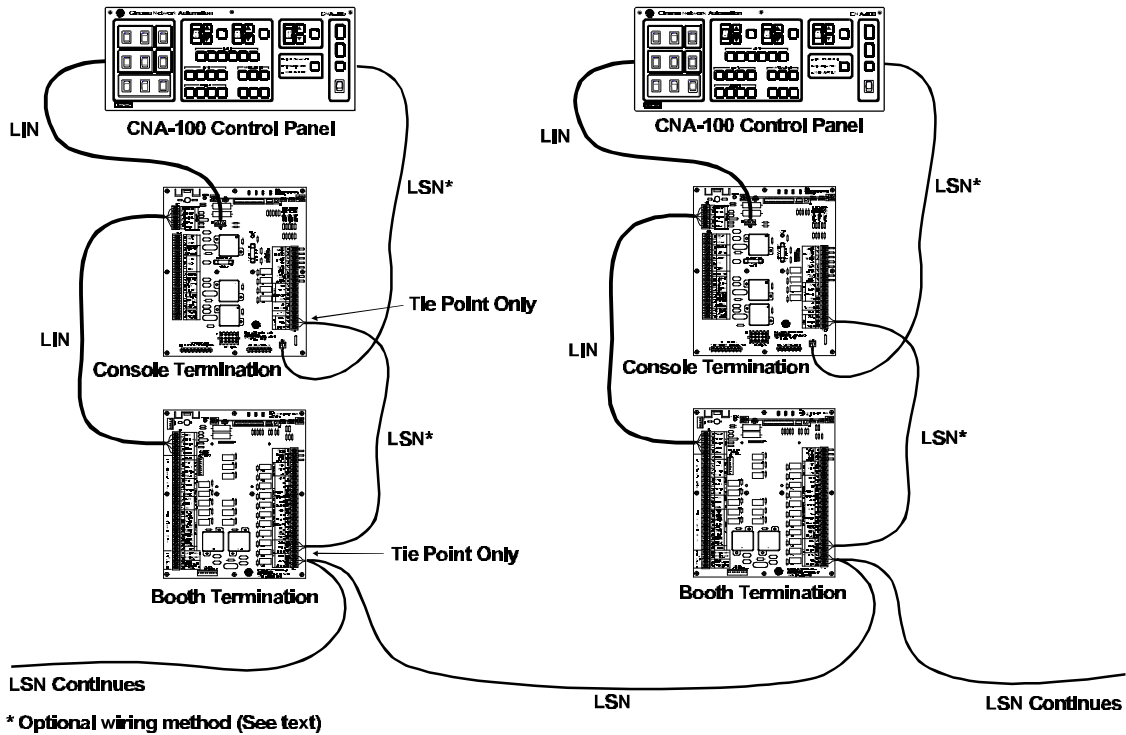

Figure 2.2

The CNA-100 Main Controller controls the Console and Booth termination boards via the LIN (Local I/O Network). This is a five wire cable that provides the serial communications as well as power to the termination panels. The termination boards are connected in a *daisy-chain* method and are mounted in the booth according to their logical location. For example, the Console termination board would typically be mounted in the console or on the pedestal, and the Booth termination board could be mounted on the wall.

LIN cable specifications: 2 twisted pair, 18 AWG with overall shield and drain wire (Alpha #5132C or equivalent).

Communication wiring between CNA-100 systems is accomplished via the LSN (Local Sync Network). The LSN provides a communications path between the CNA-100s, Remote Monitors and a PC host. The network supports synchronous communications for interlock, copy functions and remote status and control.

Figure 4 shows the LSN cable wired between the main controller and termination boards. The connections on the termination boards are tie points only, that provide a path to the main controller. It will typically be more convenient for the installer to connect CNA-100 systems together at the Booth termination board.

The cable is 2 conductor, twisted pair with a shield. Wire gage is dependent on the length of wire needed. In general, 24 AWG is sufficient. Many cable manufactures offer a broad range of 120-ohm cables designed for RS-485 applications.

LSN cable specifications: Twisted pair, 24 AWG with overall shield and drain wire (Alpha #6412, Belden #9841 or equivalent).

When planning the communications wiring, keep the cable away from equipment that generates electrical noise, such as power conduits, fluorescent lighting fixtures, air conditioners, etc. Choose cable routing paths in such a way to prevent damage to the cable.

The optimal method for communication wiring of the LSN and LIN is the daisy-chain configuration, a system in which the transmission line continues from one unit to the next. See figure 2.3 for the daisy chain connection topology. The bus must form a continuous path. Devices must not be branched or spoked.

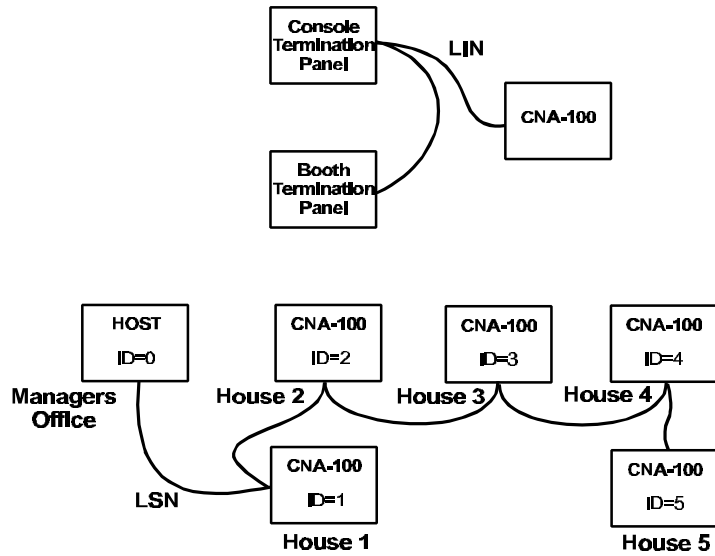

(a) Correct - The optimal configuration for the RS-485 bus is the daisy-chain connection.

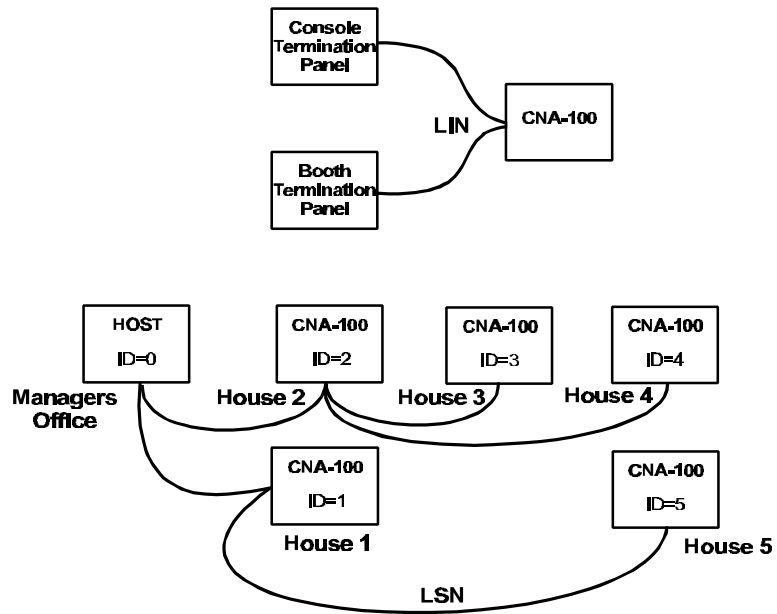

(b) Incorrect - This may create transmission line problems.

Figure 2.3

Normally the installer will wire the LSN and LIN at the 39331 Booth or 39330 Console termination board. It may also be necessary to wire directly to the 39325 Main Board (if it has not already been wired at the factory). Figure 2.4 shows how the LSN and LIN are terminated to the Main Board.

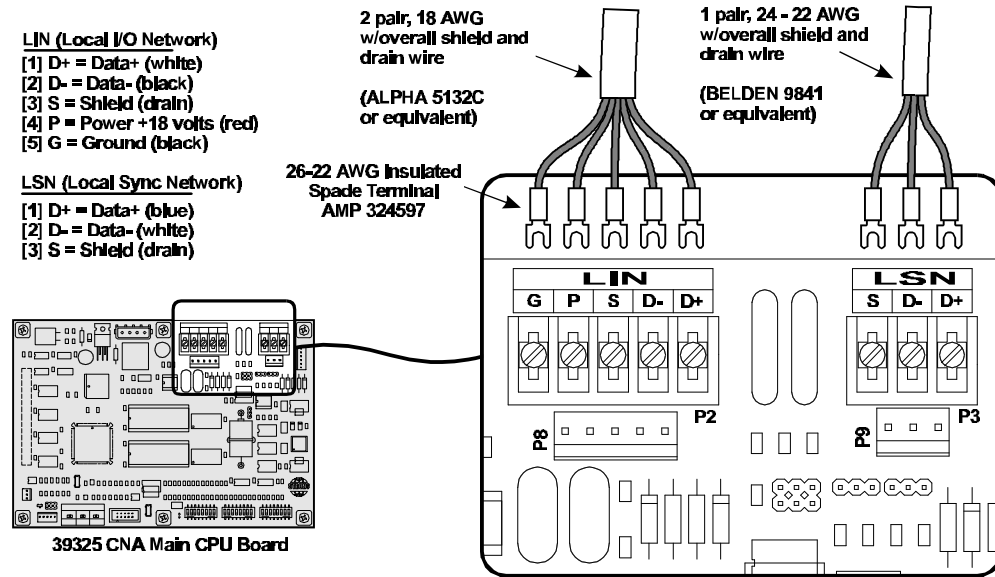

Figure 2.4

Configuring the System

The LSN can support up to 64 devices (CNA-100s, CNA-200s, Remote Status Monitors and a Host Computer). **Each device will each require a unique Sync Id number.** Id 0 is reserved for the *Host PC* and Ids 1 through 63 are assigned to CNA-100s and other devices as necessary. To keep things simple, assign the CNA-100 Ids starting at 1, corresponding to the house number and working up. The Remote Monitor's Ids, if used, should be assigned to the higher numbers starting at 62 and working down. You may want to keep Id 63 reserved for the portable or *secondary* host.

To set the Id number, first locate the eight position dip switch designated SW1. See figure 2-5.

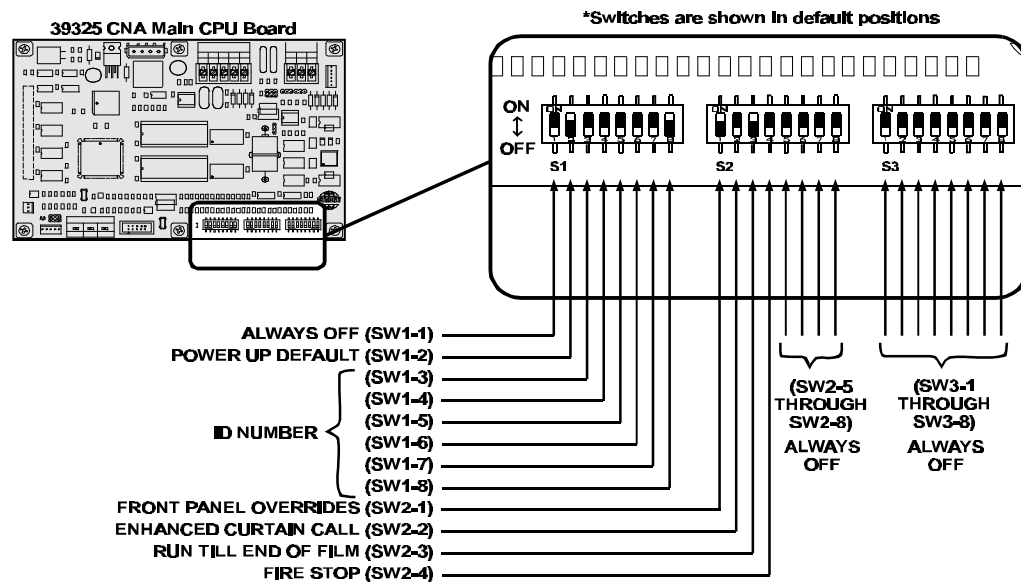

Figure 2.5

Switch Definitions

S1-1 On : Force Bootloader.
 Off : Normal Use. (Factory Default)

Note: Version 1.00 through Version 1.08

S1-2 On : Force “Supervisory Defaults” on power up. Default Supervisory data will be restored on each power up. (Factory Default)
 Off : Will **not** overwrite user-programmed supervisory data on power up. If you change any of the default settings with the Host program this switch must be off or the next time the CNA-100 is powered

up all user settings will be over-written with the defaults.

Note: Version 1.00 through Version 1.08

S1-3 through **S1-8** are used to set the ID number. The number is represented as a 6-bit binary number which allows for 64 possible ID numbers (0-63). Do not use 0 (zero) as an ID number. It has been reserved for the PC Gateway Interface. Each bit (switch) has a decimal value. Add up the decimal values to get the ID number. For example, ID number 15 would be $8+4+2+1=15$ or a DIP switch setting of 001111. See Figure 2.15.

S1-3 On : 1 Decimal value = 32
Off : 0 Decimal value = 0 (Factory Default)

S1-4 On : 1 Decimal value = 16
Off : 0 Decimal value = 0 (Factory Default)

S1-5 On : 1 Decimal value = 8
Off : 0 Decimal value = 0 (Factory Default)

S1-6 On : 1 Decimal value = 4
Off : 0 Decimal value = 0 (Factory Default)

S1-7 On : 1 Decimal value = 2
Off : 0 Decimal value = 0 (Factory Default)

S1-8 On : 1 Decimal value = 1 (Factory Default)
Off : 0 Decimal value = 0

Note: Version 1.00 through Version 1.08

S2-1 On : Enable front panel overrides. The Sound, Lights, Lens/Masking and Auxiliary front panel switches will override the outputs without affecting the program. The next instruction will override any manual changes. (Factory Default)
Off : Disable front panel overrides. The Sound, Lights, Lens/Masking and Auxiliary front panel switches are only used for programming.

Note: Version 1.00 through Version 1.08

S2-2 On : Enables the new Curtain Call function and overrides the original Curtain Call function. Place the Curtain Call cue at a distance before the next cue that is equal to the curtain close time. When

the CNA-100 sees the Curtain Call cue, the curtains begin to close, the changeover closes and sound is muted. At the next cue, the curtains will begin to open. After the CURTAIN CLOSE TIMER counts down to zero, the curtain will be fully open and the changeover will open and the sound is selected.

Off : Original Curtain Call function. (Factory Default)

Note: Version 1.07 through Version 1.08

- S2-3** On : Enables the “Run til End of Film” function. This overrides the normal 7 second motor off delay. The projector motor will run until the film runs out of the failsafe. (Factory Default)
- Off : Disables the “Run til End of Film” function. The projector motor will shut off after the normal 7 second delay.

Note: Version 1.07 through Version 1.08

- S2-4** On : Enables the “Fire Stop” function.

39331 Booth Termination Board - Converts the Remote Stop input to a Fire Stop input and the Slide Projector relay (K13) to a Fire Stop output. Fire Stop *acts* like a Remote Stop with the following exceptions:

- Sound is Muted.
- Slide Projector on *39330 Console Termination Board* is turned off *or* held off on.
- K13 relay (Slide Projector) on Booth Termination board is turned on.

39332 Termination Board - Remote Stop input must be enabled on board. (W1-OPT1 jumper across pins 2 and 3 changes the Film Tension input to a Remote Stop input.) Converts the Remote Stop input to a Fire Stop input. Fire Stop *acts* like a Remote Stop with the following exceptions:

- Sound is Muted.
- Slide Projector is turned off *or* held off.

Off : Disables the “Fire Stop” function. (Factory Default)

Note: Version 1.08

S2-5 through S3-8

On : Undefined

Off : Undefined (Factory Default)

Note: Version 1.00 through Version 1.08

See table 2-6 to configure the CNA-100s Id number with switches S1-3 through S1-8.



















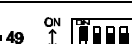



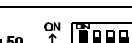



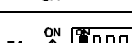
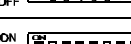

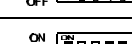
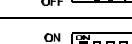
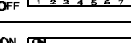
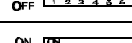
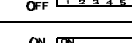
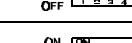
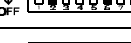
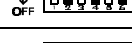
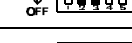
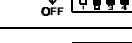
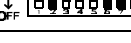
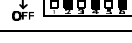
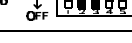
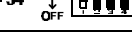
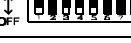

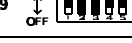
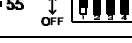



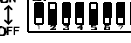

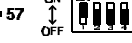



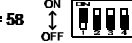



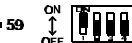

| | | | | |
|--|--|---|--|--|
| | OFF=  ON=  | ID = 16  | ID = 32  | ID = 48  |
| ID = 1  | ID = 17  | ID = 33  | ID = 49  | |
| ID = 2  | ID = 18  | ID = 34  | ID = 50  | |
| ID = 3  | ID = 19  | ID = 35  | ID = 51  | |
| ID = 4  | ID = 20  | ID = 36  | ID = 52  | |
| ID = 5  | ID = 21  | ID = 37  | ID = 53  | |
| ID = 6  | ID = 22  | ID = 38  | ID = 54  | |
| ID = 7  | ID = 23  | ID = 39  | ID = 55  | |
| ID = 8  | ID = 24  | ID = 40  | ID = 56  | |
| ID = 9  | ID = 25  | ID = 41  | ID = 57  | |
| ID = 10  | ID = 26  | ID = 42  | ID = 58  | |
| ID = 11  | ID = 27  | ID = 43  | ID = 59  | |
| ID = 12  | ID = 28  | ID = 44  | ID = 60  | |
| ID = 13  | ID = 29  | ID = 45  | ID = 61  | |
| ID = 14  | ID = 30  | ID = 46  | ID = 62  | |
| ID = 15  | ID = 31  | ID = 47  | ID = 63  | |

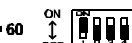
Figure 2.6

Alarm Loudness setting

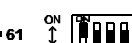
The alarm loudness can be set for one of three intensities; LOW (87 dBA), MEDIUM (94 dBA), HIGH (98 dBA). See figure 2.7 below.

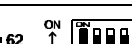
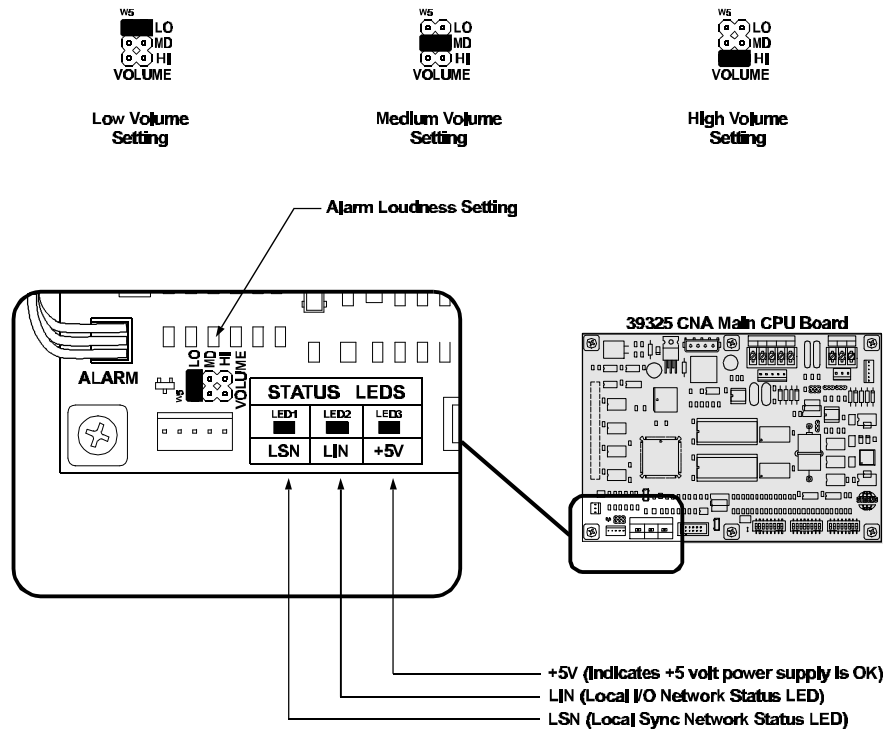

Figure 2.7

Status LEDs

There are three status LEDs on the 39325 Main CPU Board. These indicate the status of the +5 volt power supply, the LSN and the LIN. Following are the three conditions for the LIN and LSN LEDs:

Fast Blinking Rate: The CNA-100 computer is working and is communicating properly.

Slow Blinking Rate: The CNA-100 computer is working, but is *not* communicating.

Off: The CNA-100 computer has a problem.

Battery

With power off, the battery insures that stored programs will not be lost. Be sure the battery is seated properly in the sockets and the battery jumper W4 is in the ON position. The battery should provide several years of memory back up.

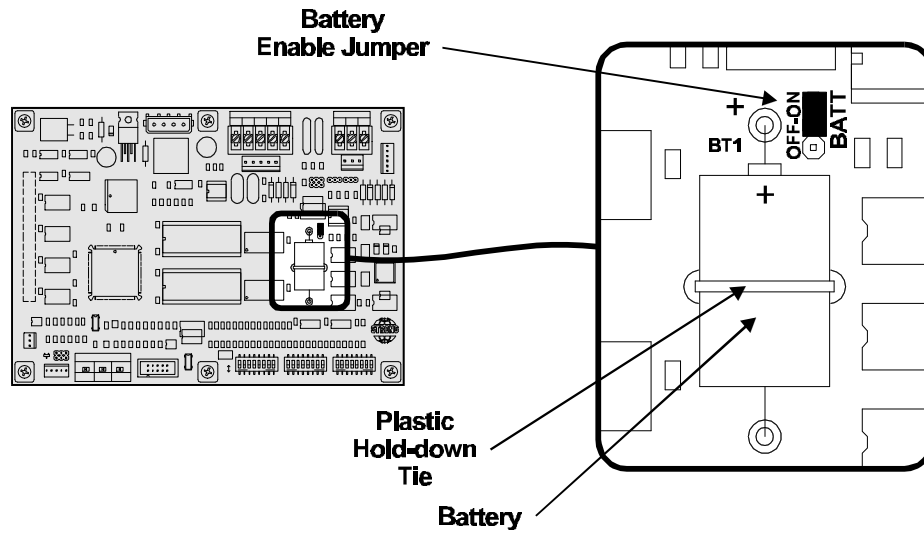

Figure 2.8

Termination Boards

All of the booth and auditorium peripheral devices (xenon lamp, projector motor, lights, etc.) are wired to the 39330 Console Termination Board and the 39331 Booth Termination Board. The Console Termination Board is shown in figure 2.10.

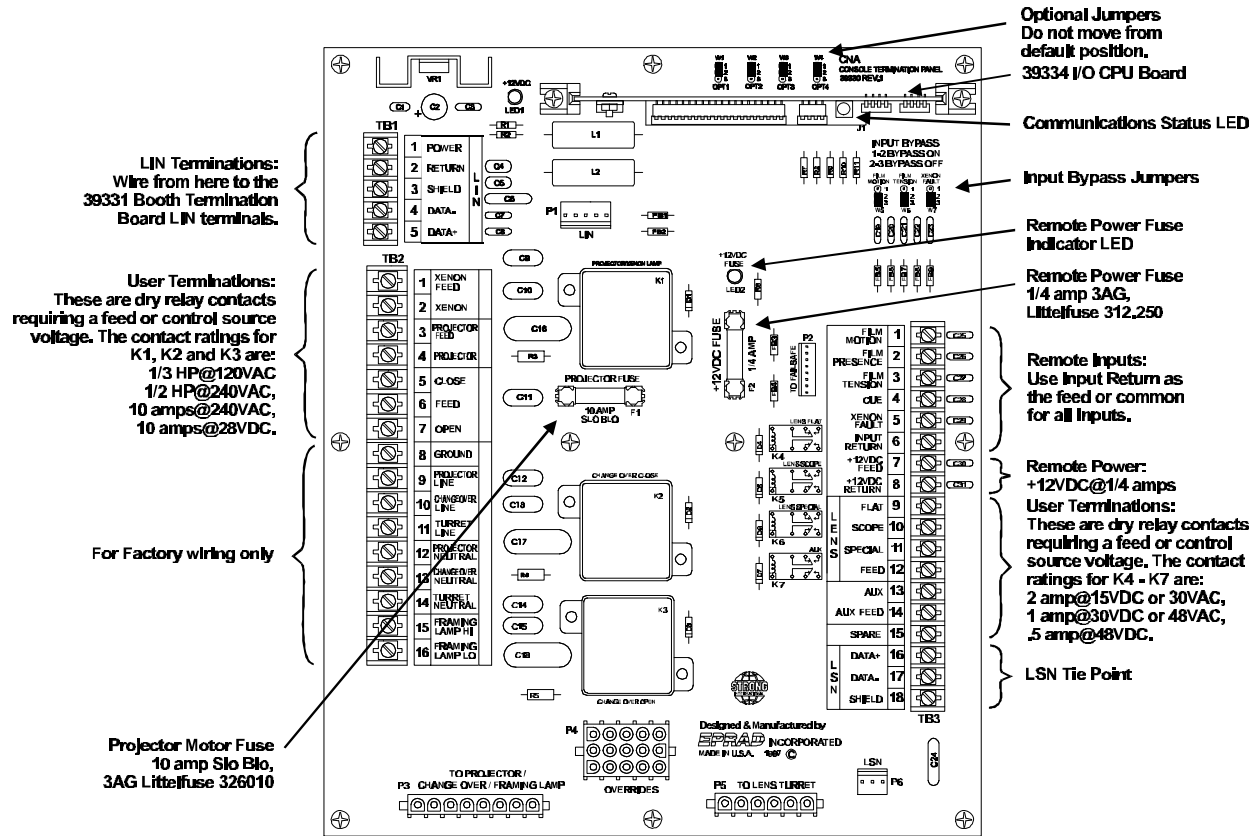

Figure 2.10

The 39334 I/O CPU Board plugs into the J1 connector on both termination boards. The purpose of this board is to handle the communications to and from the CNA-100 Main Board and to control the inputs and outputs. The Status LED on this board indicates the following:

Fast Blinking Rate: The I/O CPU computer is working and is communicating properly with the CNA-100 Main Board (Master).

1 Blink On, Pause: The I/O CPU computer is waiting for data from the Master, and the I/O is disabled.

2 Blinks On, Pause: Communications Timeout, I/O is disabled.

The Booth Termination Board is shown in figure 2.11.

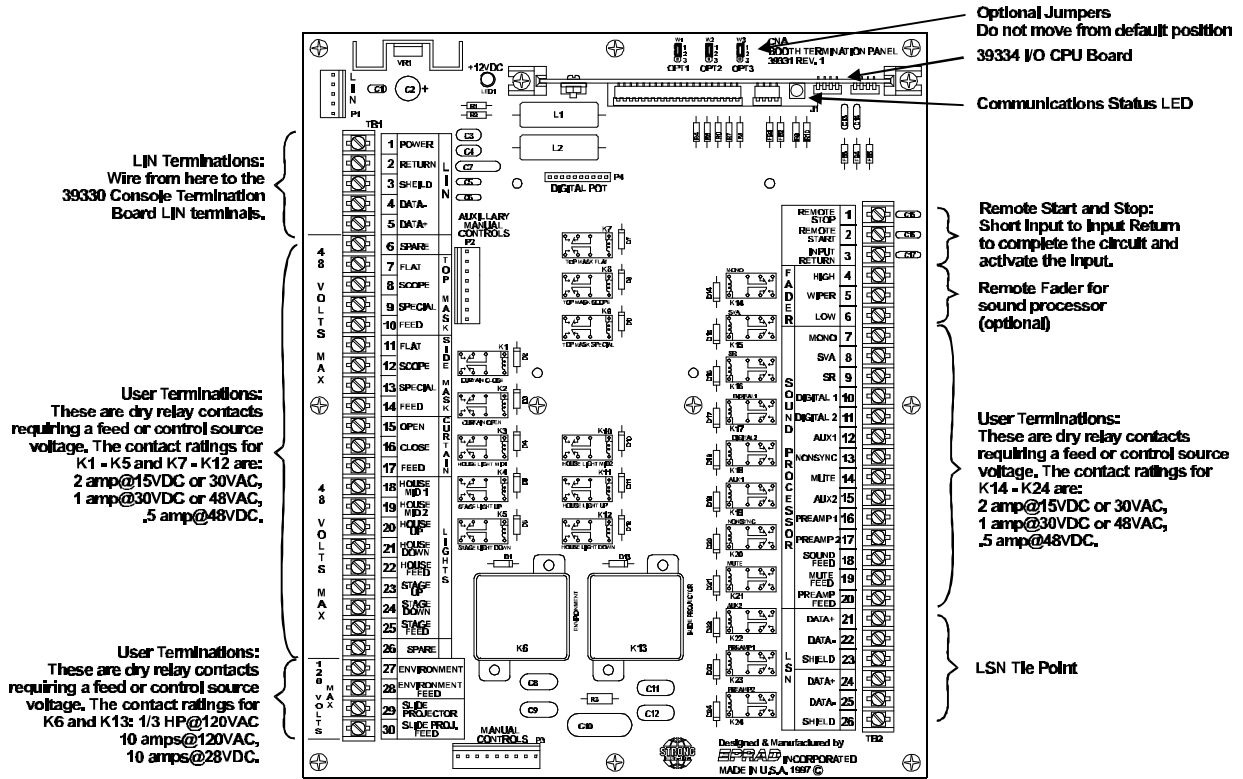

Figure 2.11

The 39332 'Single Termination' board is shown in figure 2.12. This board combines most of the functions of the 39330 and 39331 boards. If the 39332 board is used the 39330 and 39331 boards are not required. The 39334 I/O CPU board plugs into the J1 connector.

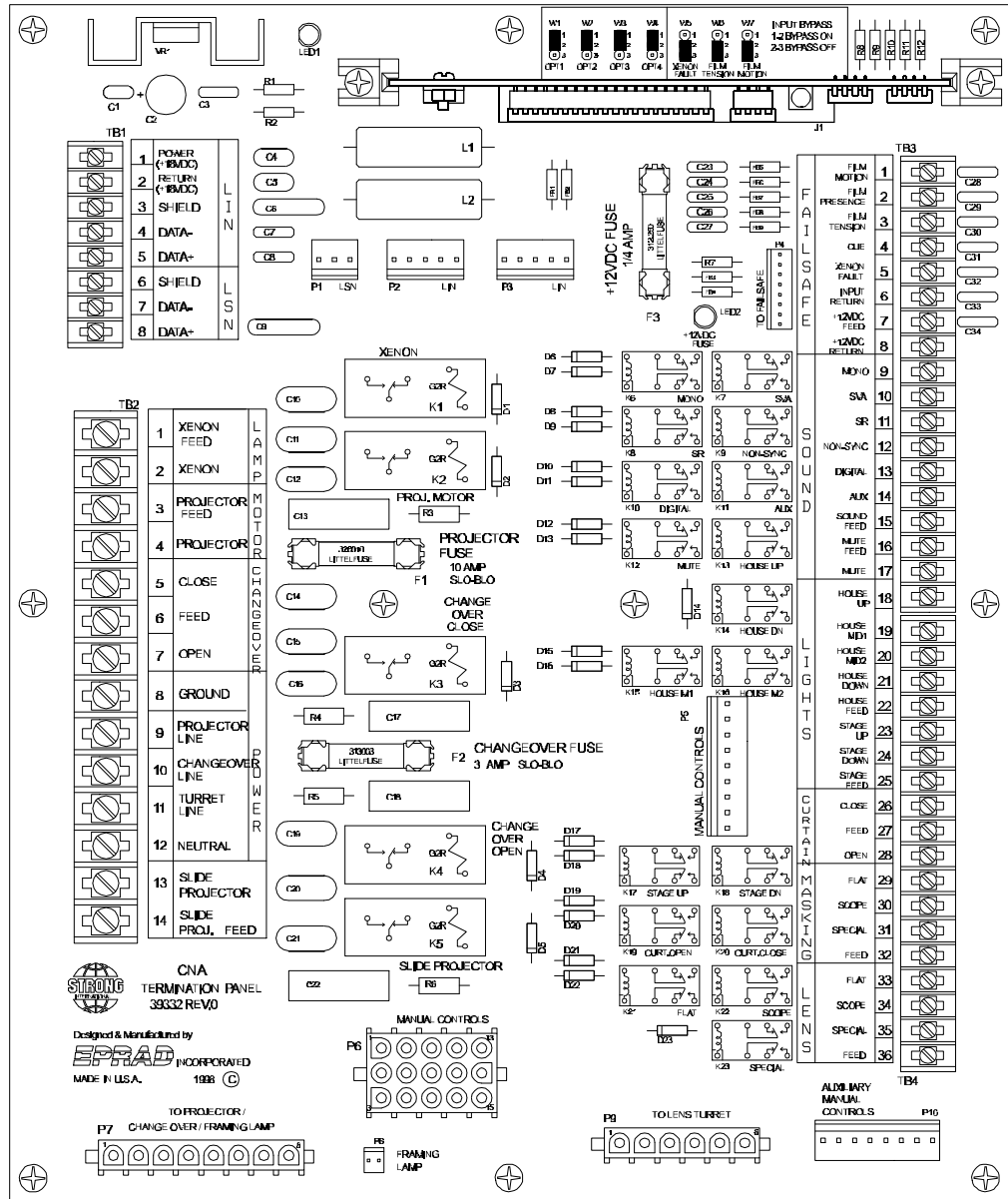

Figure 2.12

Termination Schedule for the 39332 Termination Board:

TB1 These are the LSN and LIN connections. TB1-1 through TB1-5 are used to terminate the LIN wiring *from* the CNA Automation to the 39332 board and to any other LIN devices such as the RVC-10 and ACP-50. TB1-6 through TB1-8 are used to terminate the LSN wiring from the CNA Automation. These are used as a tie point for the network connection to other CNA Automations.

TB1-1 : Power (+18VDC)
 TB1-2 : Return (+18VDC)
 TB1-3 : Shield
 TB1-4 : Data-
 TB1-5 : Data+
 TB1-6 : Shield
 TB1-7 : Data-
 TB1-8 : Data-

TB2 These are the high power connections. TB2-1 through TB2-7 and TB2-13 and TB2-14 are connected to the high power relay contacts. All relay contacts are 'dry' (no voltage) and require a feed voltage. TB2-8 through TB2-12 are special and are for factory wiring only.

| | | |
|--------|--------------------|--------------------|
| TB2-1 | : Xenon Feed | (Relay K1) |
| TB2-2 | : Xenon | (Relay K1) |
| TB2-3 | : Projector Feed | (Relay K2) |
| TB2-4 | : Projector | (Relay K2) |
| TB2-5 | : Changeover Close | (Relay K3) |
| TB2-6 | : Changeover Feed | (Relay K3 and K4) |
| TB2-7 | : Changeover Open | (Relay K4) |
| TB2-8 | : Ground | (Factory Use Only) |
| TB2-9 | : Projector Line | (Factory Use Only) |
| TB2-10 | : Changeover Line | (Factory Use Only) |
| TB2-11 | : Turret Line | (Factory Use Only) |
| TB2-12 | : Neutral | (Factory Use Only) |
| TB2-13 | : Slide Projector | (Relay K5) |
| TB2-14 | : Slide Projector | (Relay K5) |

K1, K2, K3 and K4 contacts are rated for 10 Amps @ 250VAC and 10 Amps @ 30VDC. Both the projector and changeover outputs are protected with fuses. This protects the termination board as well as your equipment. The projector fuse (F1) is a 10 amp (3AG Slo-Blo Littelfuse

#326010) and the changeover fuse (F2) is a 3 amp (3AG Slo-Blo Littelfuse #313003).

The projector, changeover and slide projector outputs have an RC network across their contacts. The purpose of the RC network is to protect the relay contacts. The capacitor C acts to suppress the discharge the moment the contacts open. Resistor R acts to limit the current when the power is turned on the next time. If the impedance of the load is not sufficiently smaller than the impedance of the RC circuit it may continue to operate even when the contacts are open. This is not a problem with the projector motor or changeover solenoid, but may be with the slide projector. If it is a problem, it will be necessary to remove R6 from the termination board.
Caution: There is enough leakage current through the RC circuit to present a potential electrical hazard to the installer.

TB3 These are the failsafe inputs and low power outputs for sound, lights, curtains, masking and lens. TB3-1 through TB3-8 are dedicated to failsafe operation. TB3-9 through TB3-36 are all low power dry relay contacts.

| | | |
|-------|-----------------|--|
| TB3-1 | : Film Motion | This input is used with a film motion device that is required for some installations. If this input is not used be sure the W7 jumper is in the bypass position. |
| TB3-2 | : Film Presence | |
| TB3-3 | : Film Tension | Becomes a Remote Stop input when the W1 (OPT1) jumper is across pins 2 and 3. Remote Stop becomes a Fire Stop input when that option is enabled at the CNA Automation. The Fire Stop alarm is activated when it is shorted to Input Return terminal. |
| TB3-4 | : Cue | |
| TB3-5 | : Xenon Fault | |
| TB3-6 | : Input Return | Current return path for all inputs. |
| TB3-7 | : +12VDC Feed | |
| TB3-8 | : +12VDC Return | |

TB3-7 and TB3-8 are used to power the film failsafe and cue detector. This power supply is fused at 1/4 amps. (Fuse F3 Littelfuse #312.250).

SOUND:

| | | |
|--------|--------------|-------------|
| TB3-9 | : Mono | (Relay K6) |
| TB3-10 | : SVA | (Relay K7) |
| TB3-11 | : SR | (Relay K8) |
| TB3-12 | : Non-Sync | (Relay K9) |
| TB3-13 | : Digital | (Relay K10) |
| TB3-14 | : Aux | (Relay K11) |
| TB3-15 | : Sound Feed | |
| TB3-16 | : Mute Feed | (Relay K12) |
| TB3-17 | : Mute | |

LIGHTS:

| | | |
|--------|----------------------|-------------|
| TB3-18 | : House Lights Up | (Relay K13) |
| TB3-19 | : House Lights Mid 1 | (Relay K15) |
| TB3-20 | : House Lights Mid 2 | (Relay K16) |
| TB3-21 | : House Lights Down | (Relay K14) |
| TB3-22 | : House Lights Feed | |
| TB3-23 | : Stage Lights Up | (Relay K17) |
| TB3-24 | : Stage Lights Down | (Relay K18) |
| TB3-25 | : Stage Lights Feed | |

CURTAIN:

| | | |
|--------|-----------------|-------------|
| TB3-26 | : Curtain Close | (Relay K20) |
| TB3-27 | : Curtain Feed | |
| TB3-28 | : Curtain Open | (Relay K19) |

MASKING:

| | | |
|--------|-------------------|-------------|
| TB3-29 | : Masking Flat | (Relay K21) |
| TB3-30 | : Masking Scope | (Relay K22) |
| TB3-31 | : Masking Special | (Relay K23) |
| TB3-32 | : Masking Feed | |

LENS:

| | | |
|--------|----------------|-------------|
| TB3-33 | : Lens Flat | (Relay K21) |
| TB3-34 | : Lens Scope | (Relay K22) |
| TB3-35 | : Lens Special | (Relay K23) |
| TB3-36 | : Lens Feed | |

Optional and Bypass Jumpers for the 39332 Termination Board:

| | | | |
|-----------|----------------|------|--|
| W1 | : Opt 1 | 1-2: | TB3-3 is a Film Tension input |
| | | 2-3: | TB3-3 is a Remote Stop input |
| W2 | : Opt 2 | 1-2: | Undefined |
| | | 2-3: | Undefined |
| W3 | : Opt 3 | 1-2: | Undefined |
| | | 2-3: | Undefined |
| W4 | : Opt 4 | 1-2: | Undefined |
| | | 2-3: | Undefined |
| W5 | : Xenon Fault | 1-2: | Bypass On (shorted to Input Return) |
| | | 2-3: | Bypass Off (not shorted to Input Return) |
| W6 | : Film Tension | 1-2: | Bypass On (shorted to Input Return) |
| | | 2-3: | Bypass Off (not shorted to Input Return) |
| W7 | : Film Motion | 1-2: | Bypass On (shorted to Input Return) |
| | | 2-3: | Bypass Off (not shorted to Input Return) |

There are three connectors for the manual control cables:

P6 Manual Controls: Xenon, Projector, Changeover and Lens

| | |
|-------|--------------------|
| P6-1 | : Xenon Feed |
| P6-2 | : Projector Feed |
| P6-3 | : Xenon |
| P6-4 | : Changeover Open |
| P6-5 | : N/C |
| P6-6 | : Changeover Close |
| P6-7 | : Changeover Feed |
| P6-8 | : N/C |
| P6-9 | : Projector |
| P6-10 | : N/C |
| P6-11 | : Lens Scope |
| P6-12 | : Lens Special |
| P6-13 | : Lens Feed |
| P6-14 | : Lens Feed |
| P6-15 | : Lens Flat |

P5 Manual Controls: Curtain and Lights

- P5-1 : Curtain Open
- P5-2 : Curtain Feed
- P5-3 : Curtain Close
- P5-4 : House Lights Up
- P5-5 : House Lights Down
- P5-6 : House Light Feed
- P5-7 : Stage Lights Up
- P5-8 : Stage Lights Feed
- P5-9 : Stage Lights Down

P10 Auxiliary Manual Controls: Masking

- P10-1 : Mask Flat
- P10-2 : Mask Scope
- P10-3 : Mask Special
- P10-4 : Mask Feed
- P10-5 : Mask Flat
- P10-6 : Mask Scope
- P10-7 : Mask Special
- P10-8 : Mask Feed

Note: P7 and P9 are for factory use only.

Installation Guidelines

The CNA-100 automation system is a microprocessor based theatre automation. Field installations over the past several years have indicated that common wiring practices vary by region and by installation. For this reason, a set of guidelines which will assist with the successful installation of the CNA-100 is listed below.

Microcomputers by their very nature, are susceptible to noise and power supply fluctuations. While the CNA-100 was designed to function in a noisy environment and survive poor installations, it is to the benefit to the end user that these guidelines be followed.

The items listed below are the result of 25 years of industrial experience and are common, accepted practice for the installation of industrial microcomputers. The cost of implementing is minimal while their benefit is immeasurable.

1. Inspect the product for shipping damage immediately upon receipt. In the event of damage, file a claim with the carrier immediately.
2. Verify that all the relays are seated in their sockets and that all cables are firmly attached.
3. Verify the proper jumper and DIP switch configurations.
4. Verify that the power supply is set for the correct line voltage.
5. Insure that all requirements of national and local electrical codes are satisfied during installation. Run *clean* power (dedicated to the CNA-100 systems only) to all automations from the service entrance panel or the closest branch panel. The line, neutral and ground wires should all run back to the main service panel (separate from all other loads). It is acceptable and preferred and preferred if all automations were run from a single distribution point.

IMPORTANT NOTE: Do not connect the projector motors, changeovers, xenon rectifiers or other heavy or noisy loads to this circuit.

6. It is imperative that the automation have a **good ground**. This is important in terms of safety and performance. The automation has an interference filter for the AC inputs. The specific intent of the filter is to reduce the effect of interference (noise) on the AC line that provides power to the unit, by providing a “leakage” path to ground from the power lines.

Important note: Unless an earth ground is provided this leakage can pose an electrical shock hazard.

In new installations use a copper conductor (not the conduit) from the automation back to the service entrance ground. Connect all automations in the booth to this ground point. This arrangement is best and most reliable. If this is not practical, (such as a retrofit for example), provide the best “earth” ground possible.

A second best setup would be to run copper wire back to the ground lug in a branch panel.

The minimum acceptable grounding method is conduit ground back to the branch box. In some installations satisfactory operation with this ground may not be possible.

7. Do not run the line voltage power wires in the same raceways as the low voltage signal wires. This is important from both a safety standpoint and a system reliability standpoint. It is best to keep the failsafe, cue detector, LIN, LSN, sound format and dimmer control wires separate from projector motor, changeover, xenon lamp, and other power carrying wires. If it is essential that they be run in the same duct, keep them separated in the duct.

Section 3

SETUP

STOP - Please note at this point you should have completed the entire installation of the automation system. If you have not, go to the *Installation* section of the manual and complete it before proceeding.

Programming the CNA-100

Programming is accomplished with the *Programming* keys and the *Program* and *Cue* numbers. The CNA-100 gives the user the ability to build and store up to 9 different programs. Each Program can use up to nine cues.

The following steps describe how to edit a program:

1. Press the PROGRAM EDIT key to activate the *edit mode*. The PROGRAM EDIT LED will toggle "on". The CUE up and down arrow keys are enabled and the PROGRAM and CUE displays will stop blinking *if* show is in progress.
2. Select the program to edit with the PROGRAM up or down arrow keys.
3. Program the Sound, Lens and Lights for each cue using the programming keys. Program the Auxiliary outputs (OUT 1 through OUT 4) if an 'Aux Board' is connected to the system. One or more of these outputs can be on at a time.
4. Use the SHOW END key to indicate the end of the program.
5. Select a different program to edit or press the PROGRAM EDIT key to deactivate *edit mode*. The PROGRAM EDIT LED will toggle "off". The PROGRAM number and CUE number *up* and *down* arrow keys will be disabled and the displays will slowly blink if the show is in progress.

Following are some simple rules to remember when programming:

Programming a SHOW END cue locks out subsequent cue numbers, keeping you from scrolling to a larger cue number.

You may edit any program while a show is in progress (including the program that is running).

When a show is in progress and you are *not* in the PROGRAM EDIT mode the PROGRAM and CUE number *up* and *down* arrow keys are disabled.

The INTERMISSION and CURTAIN CALL Keys

These are two special programming keys that allow the user to easily program a Show Intermission and a Curtain Call. The INTERMISSION KEY is used to program a show intermission at the selected cue. The cue then initiates the intermission sequence as follows:

```

Changeover Close
  Lights
  Sound
  Curtain Close
-----
7 second delay
-----
Xenon Lamp Off
Projector Motor Off
Slide Projector On

```

The Intermission is terminated and the show is re-started either by a START input (remote or local) or a CUE input (remote or local). If the show is re-started by a START input, only the projector motor and lamp are turned on. The next film cue will initiate the show start sequence. The show start sequence is as follows:

```

START
-----
Xenon Lamp On
Projector Motor On
-----
Cue n
-----
Lens/Masking
  Lights
  Curtain Open
-----
7 second delay
-----
Slide Projector Off
-----
1 second delay
-----
Changeover Open
  Sound

```

If the show is re-started with a CUE input, there is *no* need for a show start cue. The show start sequence is as follows:

```

CUE
-----
Xenon Lamp On
Projector Motor On
Lens/Masking
Lights
Curtain Open
-----
7 second delay
-----
Slide Projector Off
-----
1 second delay
-----
Changeover Open
Sound

```

The "Curtain Call" function will issue a curtain *close* at a selected cue. For example, suppose you wanted your curtains to close and the end of your trailers and open back up at the start of your feature presentation. You would place a cue at a distance before the end of the trailer that is equal to the curtain close time and another cue at the beginning of the feature. The sequence of events are as follows:

```

Cue n (with Curtain Call)
-----
Curtain Close
Sound (if programmed)
Lights (if programmed)
-----
Cue n+1
-----
Lens/Masking
Changeover Close
Lights
Curtain Open
-----
7 second delay
-----
Changeover Open
Sound

```

Operating the CNA-100

In the "Ready to Run" state, the FILM PRESENCE LED will be "off", and the START LED will be blinking. Select the program 1 through 9, that you want to run with the up/down arrow keys. Press the START switch to start the show. The START LED will toggle "on".

When a show is running, the current states of the Sound, Lens, Lights and Auxiliary will be shown with the LEDs "on". The cue number displayed is the next cue the CNA-100 is waiting to see.

Soft Manual Overrides

During run mode, pressing any of the Sound, Lens, Lights or Auxiliary keys will drive the output to that state. Note: This will not alter the saved program. At the next cue the program will override any manual changes.

Synchronous Operation

The CNA-100 systems are capable of running film synchronously in a multi-projector booth. The CNA-100 can be programmed for any one of nine sync loops. This allows for up to nine different sync loops on the network at one time. Pressing the SYNC key will activate the sync operation and disable the up/down arrow keys. (This prevents the machine from joining another sync loop that may be running and causing a fault on those machines when it drops off the loop.) To change the SYNC LOOP number, press the SYNC switch to deactivate. Set the loop number with the up and down arrow keys and press the SYNC switch again to activate. The LED on the SYNC switch indicates whether sync mode is active or not.

To run in sync the following conditions must be true:

1. A *sync cue* must be added to the beginning of the film. This is the first cue that is seen by the automation. It acts to initiate the start up sequence for each machine.
2. Sync Mode on each automation in the loop must be enabled.
3. The sync loop number on each automation in the loop must be the same.

To begin a movie, insure that the sync cue is positioned somewhere before the cue detector on the first machine. Press the [START] switch on any machine in the loop. All projectors will start simultaneously. As the sync cue passes through each projector, the show start sequence will initiate.

At the end of the show each machine will shut down independently as the tail of the film runs out of the projector. On endless loop systems all projectors will continue to run until the last machine see the end cue. At that time all projectors will shut down simultaneously.

System Status Messages

The CNA-100 contains a list of status messages that can be displayed due to various internal or external conditions. Most of these messages displayed indicate system faults. There are also some internal power up and reset diagnostic messages, most of which will not and should not be displayed under normal operating conditions.

Fault Condition Messages

The Fault Condition messages can be divided into three categories: Internal *memory* faults, *run-time* faults and *failsafe* faults.

Memory Faults

The internal memory faults are generated when there is a "checksum" error. Briefly, a checksum is an arithmetic sum of the contents of memory that is stored in the memory itself and is re-computed and checked each time the CNA-100 is powered up. Each of the Programs (1 through 9) and the System Parameters have a checksum. The fault messages are displayed and "blinked" rapidly on the three digital displays.

| <u>Message</u> | <u>Description</u> |
|----------------|----------------------------------|
| P 0 1 | Program 1 Checksum Fault |
| P 0 2 | Program 2 Checksum Fault |
| P 0 3 | Program 3 Checksum Fault |
| P 0 4 | Program 4 Checksum Fault |
| P 0 5 | Program 5 Checksum Fault |
| P 0 6 | Program 6 Checksum Fault |
| P 0 7 | Program 7 Checksum Fault |
| P 0 8 | Program 8 Checksum Fault |
| P 0 9 | Program 9 Checksum Fault |
| P A r | System Parameters Checksum Fault |

If any of the *Program* memory faults are displayed on power up, *clear* the fault by pressing the ALARM CANCEL key. Press the PROGRAM EDIT key to enter the edit mode. Cursor to the program that has the checksum error. Scroll through the program to verify it. If all the steps look okay, press any key to re-calculate the checksum. Press the PROGRAM EDIT key again and cycle power to verify that there is no other checksum errors.

A *System Parameters* memory fault will be displayed if there is a checksum error. This error must be cleared from the *Host PC*, by copying the system parameters from the Host Program to the CNA-100. If you are not using a Host PC, the system will be using the *default* parameters and can not issue a System Parameters Checksum Fault.

Run-Time Faults

These three messages will be displayed if there are the following communications faults.

| <u>Message</u> | <u>Description</u> |
|----------------|---|
| L I n | Local I/O Network Fault |
| L S I | Local Sync Interlock Fault |
| L S C | Local Sync Communications Timeout Fault |

The Local I/O Network Fault is caused due to a loss in communications with a Local I/O Network device or another network problem. This could be the Booth Termination Panel, Console Termination Panel or other I/O Network device or a wiring problem.

A Local I/O Network fault will cause the CNA-100 to display "L I n". This fault will cause a shutdown during a show or prevent a show start between shows. This fault is latched and you are required to press the ALARM CANCEL key to clear the fault. Although this will cancel the fault and allow a show to start, there is a problem with the Local I/O Network or one of the devices and it must be repaired.

A Local Sync Interlock Fault is caused when either a master or one of the slaves in the sync loop has lost it's sync input (sync switch). All CNA-100s on the sync loop will display "L S I" and sound their alarms. This message will also be displayed if one of the units on the loop had a "watchdog reset". If this was the case, all units will display this message except for the one that had the watchdog reset.

A Local Sync Communications Fault is caused when there is a loss of communications with a unit on the sync loop. This could be due to a loss of power of the master or one of the slaves on the loop. In this case all units on the sync loop would display "L S C" except for the one that lost its power. This fault can also be caused by defective wiring, such as an open or short on the LSN

communications link.

Sync Interlock Failsafe Fault

This fault indicates the master or one of the slave CNA-100s has a failsafe fault that is preventing the interlock loop from *resuming* a show. The following message is displayed to indicate this fault.

| <u>Message</u> | <u>Description</u> |
|----------------|-----------------------------|
| L S r | Not Ready To Resume Fault |
| L S r | Need Master To Resume Fault |
| L S r | Not Ready To Run |

The Not Ready To Resume Fault indicates that the automation cannot start a show because a least one of the CNA-100 remotes are not in the “Ready to Resume” condition.

The Need Master To Resume Fault indicates that there is no master. The master may be lost if the communication wires are disconnected, power is lost or the sync input (sync switch) is not enabled at the master.

The Not Ready To Run Fault indicates that the automation cannot start a show because a least one of the CNA-100 remotes are not in the “Ready to Run” condition

Power Up Messages

Upon power up, the CNA-100 will display a series of messages. The following messages should be displayed at power up:

| <u>Message</u> | <u>Description</u> |
|----------------|-----------------------------|
| 1 0 5 | Version Number (2 seconds) |
| 2 1 0 | Checksum Number (2 seconds) |
| P U P | Power Up Reset (2 seconds) |

These messages will be displayed in this order each time the CNA-100 is powered up. Each message is displayed for about 2 seconds. The first message is the software version number (version 1.05). The second is the software checksum number, and the last message indicates to the user that it is a power up condition.

Timing Diagrams for the CNA-100

The following Timing Diagrams show timer values, output configurations and cue events for all the outputs. **Timers and output configurations such as pulsed/maintained, power up and fault conditions are defaulted on the CNA-100, and can only be changed with the Host Program.** These timing diagrams can be extremely useful to help understand the operation and capabilities of the CNA-100. The first timing diagram shows the “Standard Operation” from power up to show end. Standard Operation implies a running a program with no interruptions (stop or faults) or special effects (curtain call or intermission). The defaults for each outputs are indicated in the last column of the timing diagram. Default timer values and pulse durations are indicated in the bottom margin of the timing diagram. The diagram indicates automatic and programmed outputs.

The second timing diagram shows the Fault/Stop Shutdown and Restart Sequence. The area of interest is the shaded portion of the diagram. This shows the default ‘Fault-to’ conditions:

Projector Motor and Lamp = OFF
Slide Projector = ON
Changeover = CLOSE
Sound = NON-SYNC
House Lights = UP
Stage Lights = UP

These default conditions can be configured in the CNA-100 Set-up Supervisory section of the Host PC Program.

The third timing diagram shows the Intermission Stop Sequence. The area of interest is the shaded portion of the diagram. At the Intermission cue the Changeover and Curtain will close. Seven seconds later the Projector Motor will shut off and the Slide Projector will turn on. Sound, Lights and Out 1, 2, 3, and 4 can be programmed for any state during the intermission. A Restart will start the Projector Motor and a film cue will initiate the show start sequence.

The last timing diagram shows the Curtain Call Sequence. The area of interest is the shaded portion of the diagram. At the Curtain Call cue, the curtain begins to close. The ‘next’ cue will begin to open the curtain. The ‘curtain close time’ is determined by the distance between the curtain call cue and the next film cue. Sound, Lights and Out 1, 2, 3, and 4 can be programmed for any state during the Curtain Call.

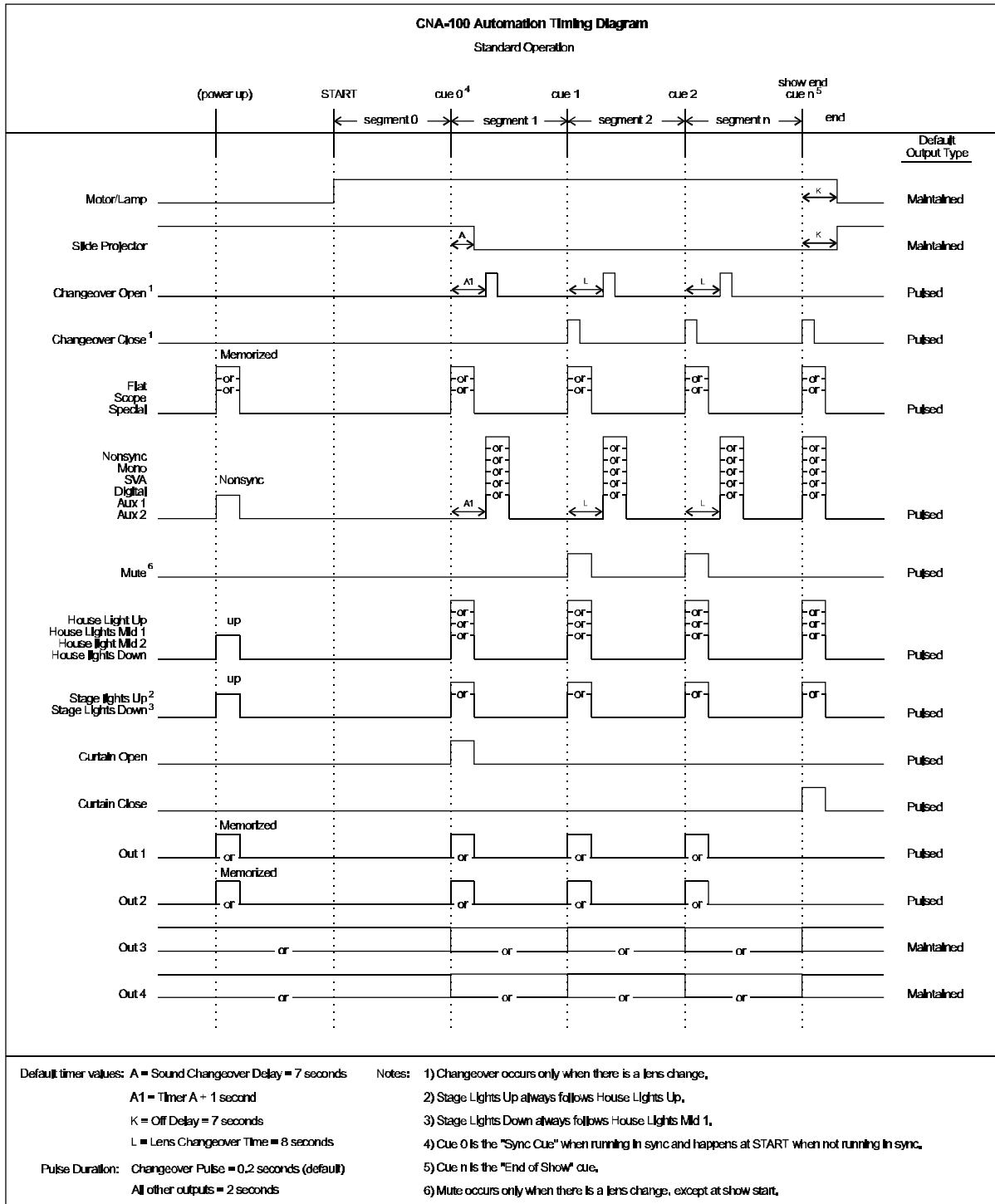

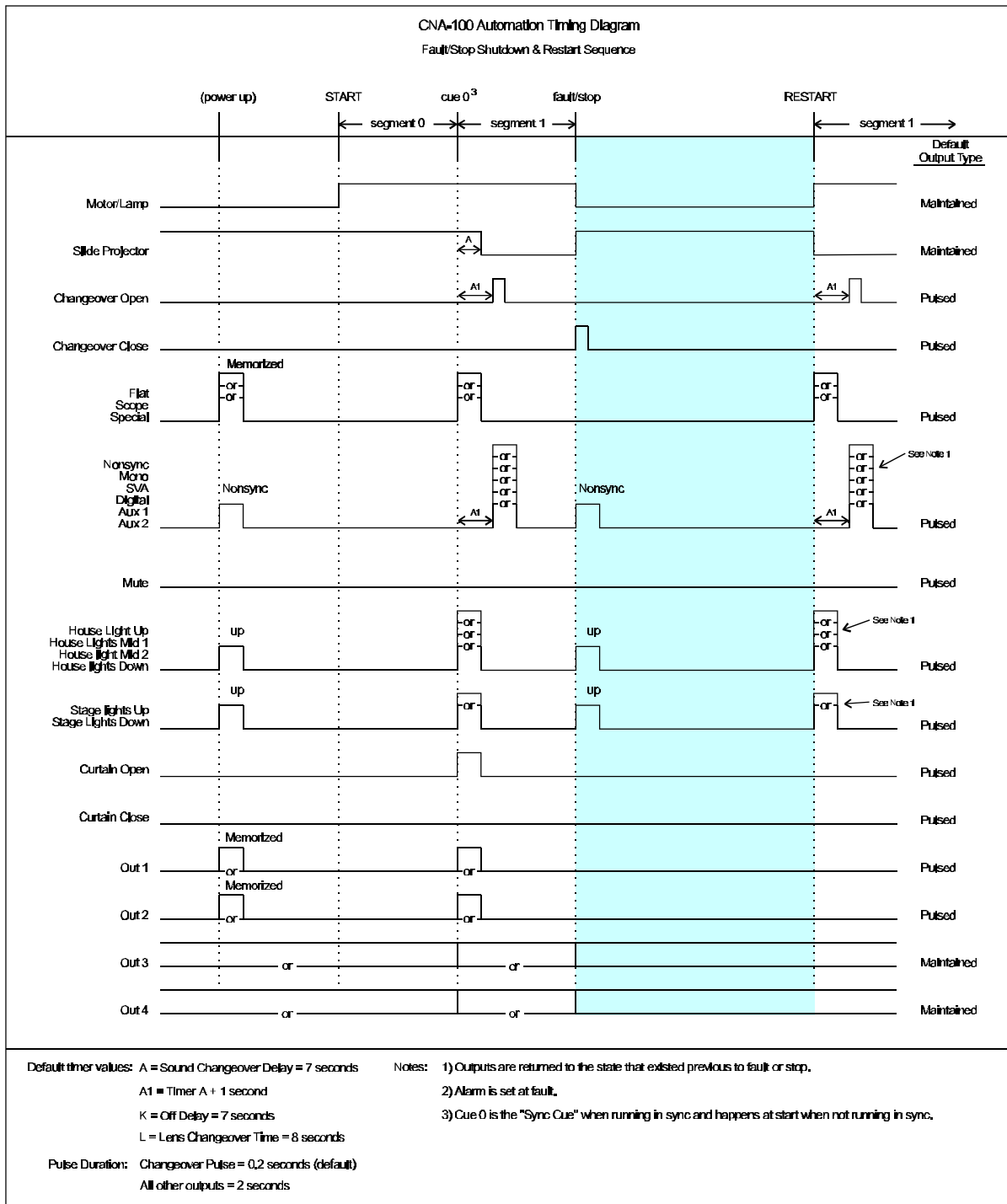

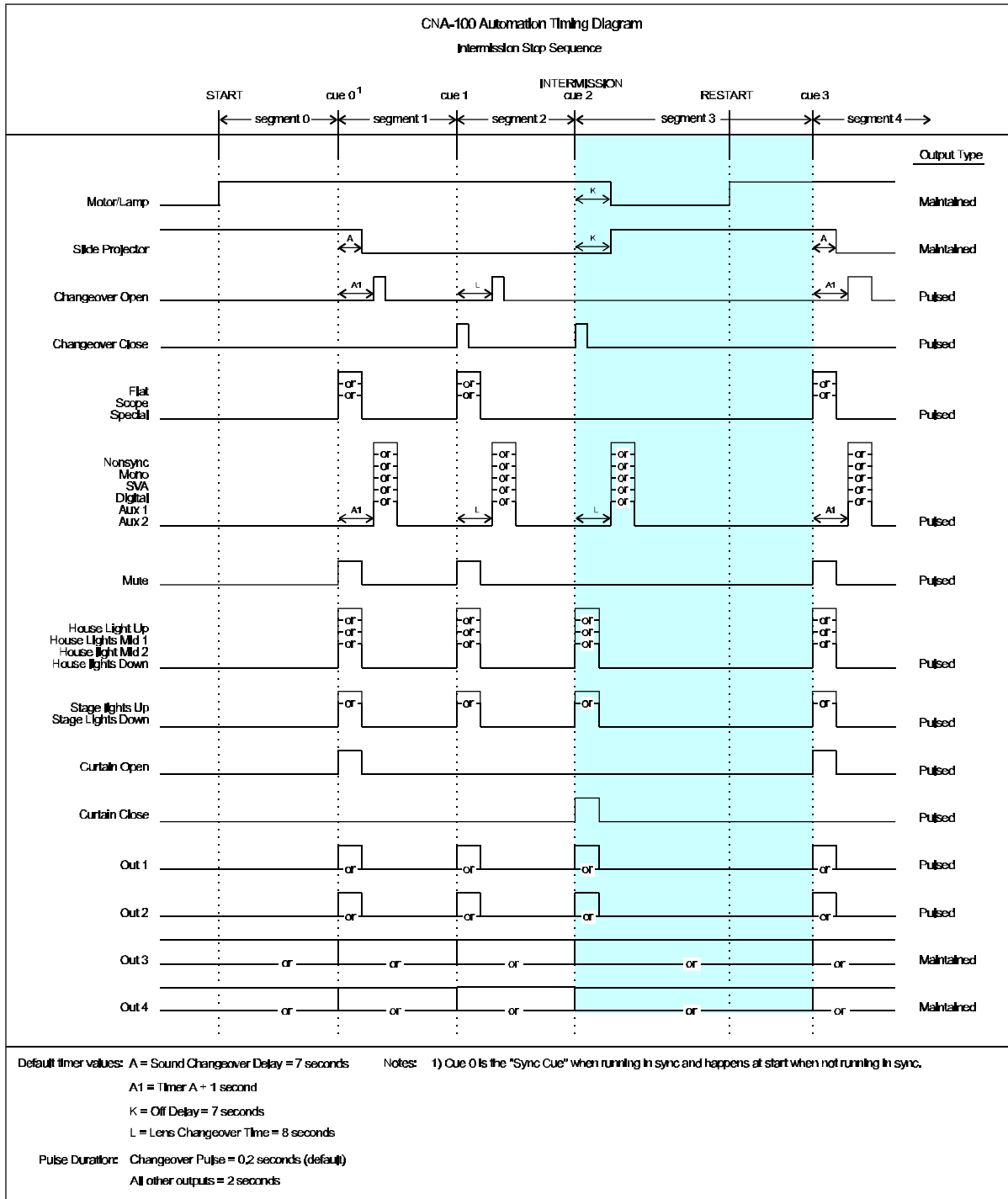

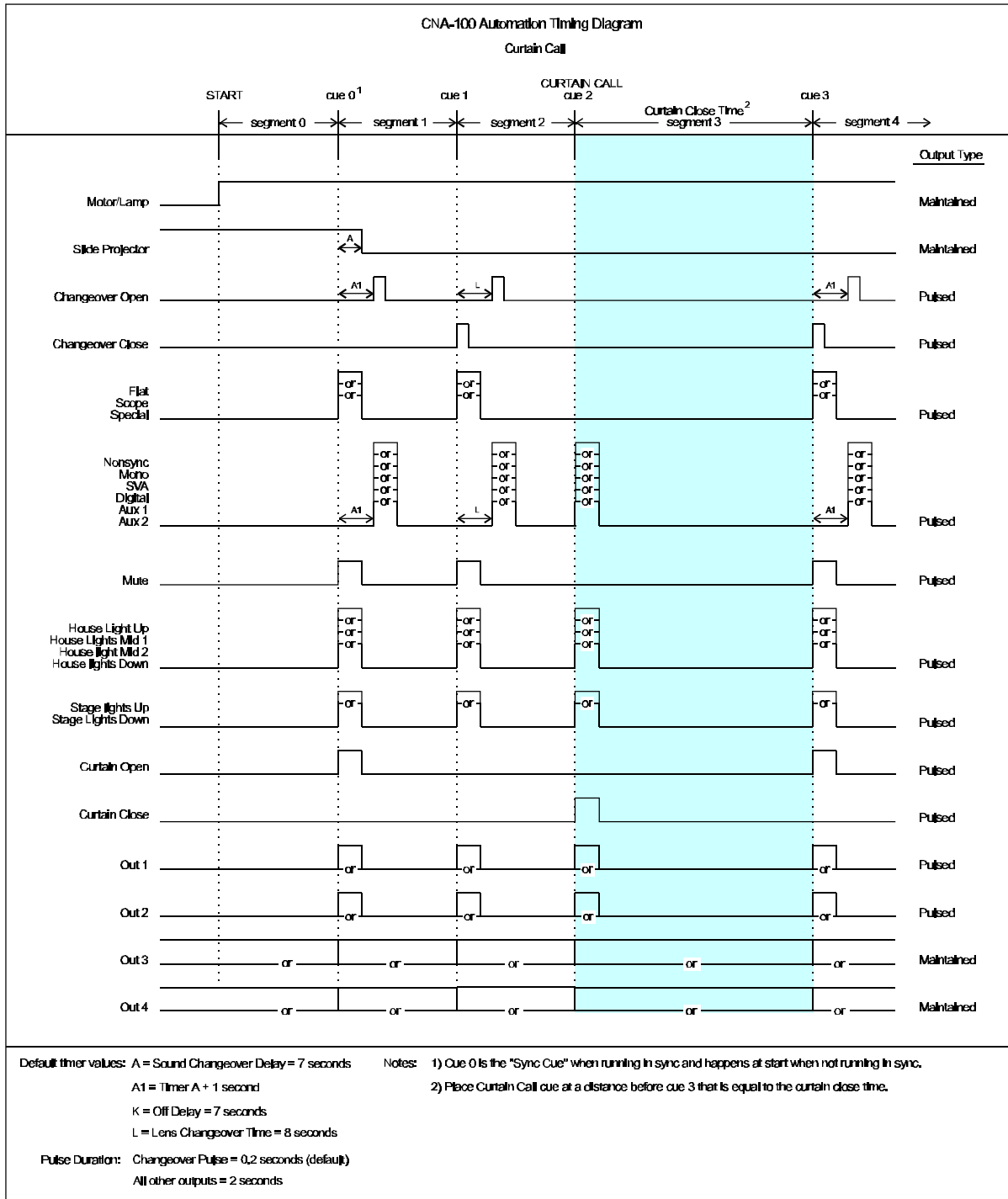

Section 4

ADDENDUM

Software Changes

This section details the CNA-100 software changes.

Version: 1.05
Checksum: 210
Date: 7/15/97

This version requires Host V1.003 and is compatible with CNA-200 V1.006.

1. Aux Output on Console Termination Board now follows "Slide Projector" output.
2. Lens and Masking now support programmable "Power Up" default.
3. I/O Communications now "resends" setup data to I/O devices when System Parameters is updated. (Sound C/O Pulse time.)
4. Added "(t)" and "(c)" to Sync protocol to indicate "Timed" or "Clock" Start mode.
5. Stop key now works the same everywhere - forcing switch to "Show Hold" mode (to other controls).
6. Added "Check Focus" beep to indicate Clock Start or Timed Start from another control.

Version: 1.06
Checksum: 216
Date: 9/17/97

This version requires Host V1.004 and is compatible with CNA-200 V1.007.

1. Added support for newly designed MCD-35 Cue Detector for Local I/O Network (LIN).
Note the CNA software "Auto Detects" the MCD-35 the first time it responds to a poll. Once this board is detected the "Motion" and "Presence" inputs on the Console Board are then ignored. It would be a good idea to leave the Console Board inputs "open" rather than "shorted" to cause a fault in the event the the MCD-35 board does not respond to polls on power up. (Not a requirement, just a suggestion...)
2. Increased Motion Fault time from 2 seconds to 3 seconds.

Version: 1.07
Checksum: 23
Date: 2/02/97

This version is compatible with CNA-200 V1.009.

1. Added S2-2 "Enhanced Curtain Call" DIP switch configuration.
2. Added S2-3 "Run til End of Film" DIP switch configuration.
3. Added "Resume-bypass" of the Sound Changeover Delay. The Sound Changeover Delay is now bypassed for a Resume.
4. Data Entry now shows "next state" of program.

Version: 1.08
Checksum: 103
Date: 10/16/98

This version requires Host V1.005 and is compatible with CNA-200 V1.011.

1. Added LIN communications support for new ACP-50 Auxilliary Control Panel device. Added support for ACP-50 Volume & Mute Keys. Volume keys are however disabled for this version pending the development of the remote volume control.
2. Selecting new sound formats now clears the new "Mute" flag.
3. Sound and Lens now pulse when set to the "same" state again.
4. Added Fire Stop Option Dip switch:
S2-4 OFF = Normal Stop, ON = Fire Stop

This new "Fire Stop" option:

- a. Stops the Show,
- b. Forces Sound to Mute,
- c. Forces Console Slide Projector off,
- d. Forces Booth Slide Projector On (new fire stop output).
- e. Forces all other outputs to their "Fault To" state.

When S2-4 is Configured for "normal" operation both Slide Projector outputs perform the "Slide Projector" function and the Remote Stop simply stops the show if it is in progress (both same as in previous version).

5. Check Focus Alarm now only follows others on our SYNC loop if our SYNC switch is enabled.