

CNA-200 Cinema Network Automation

Reference Manual

September 1998

WARRANTY INFORMATION

The CNA-200 Cinema Network Automation, sold by STRONG INTERNATIONAL, is warranted against defects in materials and workmanship for one year from the date of purchase. There are no other express or implied warranties and no warranty of merchantability or fitness for a particular purpose.

During the warranty period, STRONG INTERNATIONAL will repair or, at its option, replace components that prove to be defective, provided the unit is shipped prepaid to the manufacturer directly or via an authorized distributor. Not covered by this warranty are defects caused by modification, misuse or accidents and any further damage caused by inadequate packing for service return.

STRONG INTERNATIONAL's obligation is restricted to the repair or replacement of defective parts and under no circumstances will STRONG INTERNATIONAL be liable for any other damage, either direct or consequential.

Information in this document is subject to change without notice. No part of this document may be reproduced or transmitted in any form or by any means, electronic or mechanical, for any purpose, without the express written permission of STRONG INTERNATIONAL.

© 1997, 1998 STRONG INTERNATIONAL. All rights reserved.

What is CineNet?

Strong International's CINENET™ is an automation and control network designed specifically for the Motion Picture Theatre Industry. CINENET™ provides a low cost connection to various control and I/O devices in the projection booth, auditorium, and throughout the theatre complex.

CINENET™ is divided into two network layers: The Local Synchronous Network (LSN) is a facility-wide data network that provides advanced interlock control, user-selected data transfer and real-time remote automation status. The Local I/O Network (LIN) is designed to provide remote I/O control for each screen in a complex.

The CINENET™ network offers many advantages over point-to-point wiring such as reduced installation costs, reduced wiring errors and high noise immunity. CINENET™ also allows management to program and access real-time status of all auditoriums in the theatre complex from a central location using a personal computer.

Strong International will continue to develop new CINENET™ products that will provide the control and flexibility the theatre industry demands.

Section 1

SYSTEM OVERVIEW

Preface

The CNA-200® Cinema Network Automation is a CINENET™ compatible automation system specifically designed for the Motion Picture Theatre industry. The system is modular in design, consisting of the operator interface and system I/O devices. The Main Computer and each peripheral device is defined by its common functions and locations in the booth. The devices *within* the system communicate with each other on a serial communications link. Automation systems and remote stations distributed throughout the booth and other areas of the multiplex communicate on a second serial communications link.

To enhance the operation of the CNA-200 and provide a broader level of control, the CINENET™ Gateway PC Card and Host software is available. This product will provide a PC interface to the CNA-200 automations. The Host PC and software will allow management to access programming, real-time data and diagnostic information from all systems connected to the network.

Users and Installers of the CNA-200 are encouraged to read all sections of this operators manual to become familiar with the system and its capabilities. This automation was designed to be easy to setup and operate. But it is the responsibility of the user to learn how to do so. With a solid understanding of how the CNA-200 operates you can take full advantage of all its capabilities. The Installation section of the manual provides detailed wiring diagrams to aid in the installation process. A special section entitled *Installation Guidelines* is included to provide the installer with a set of important rules to follow that will help insure a successful installation.

If while installing or operating the CNA-200 automation you find any part of the manual to be unclear or incorrect, please let us know.

A CNA-200 demonstration box is available for purchase from Strong International that will facilitate in the training of employees. Call Strong International at 1-800-424-1215 if you are interested.

Product Overview

The CNA-200 Cinema Network Automation is designed to be the most versatile, capable and reliable system ever designed for motion picture theatres.

Computerized operation allows options including nine separate programs, each capable of twenty separately cued sequences of all available functions. An internal clock can provide programmed start times, and a "Cue Learn" feature automatically initiates the next sequence in the event of a missed film cue.

The CNA-200 allows two levels of programming: a basic level for programming of normal operations and schedules, and a more extensive level for use by supervisory personnel. Programming of either level is easily accomplished once familiar with the system.

The CNA-200 controls all booth and auditorium functions, including House Lights with half-level, Stage Lights, Curtain (with Curtain Call feature), eight Sound formats, Lens/Masking control, Special Projector operation, and Intermission functions such as a Slide Projector. Each system is equipped with network and local copy functions, allowing the user to copy programs and set-up data from a remote CNA-200. Interlocked operation is easily accomplished for up to 64 units. The control panel includes a full set of manual controls.

Users of the CNA-200 are encouraged to study all sections of this Operator's Manual to become familiar with the system and its capabilities.

The CNA-200 is a *single-cue* automation. This means that events, such as lens, masking and sound changes, are initiated by a cue (normally foil placed on the film). These events are stored in the CNA-200's memory and are called *Programs*. The CNA-200 gives you the ability to build and store up to nine different programs. Each program can contain up to ninety-nine *instructions* which are performed sequentially. An *instruction* is a particular function that will be executed during a *program step*. It may have a timed relationship to the step; that is, stage lights may be programmed to dim ten seconds after the instruction is encountered in the program. Each function is identified by an *instruction number*.

The CNA-200 incorporates a unique feature called *Cue Learn* in which cue times for each program are stored in the computers memory. Cue Learn is activated by the operator before a film is run for the first time. All cue times will then be "Learned" or stored in memory. On all subsequent runs the CNA-200 expects to see the film cues at a particular time. If a cue is not seen, due to a missing or worn cue foil, the computer will automatically "issue" a cue which will advance the program and keep the show running properly. Cue Learn also makes it possible to operate a show without film cue foil at all!

The CNA-200 also provides a configuration or set-up section that allows you to customize the system. This section is called “Supervisory”. Supervisory is a set of system functions including relay contact configuration, power up states, maintenance schedules, interlock configurations, along with other system parameters most of which will be set up at system installation and not changed unless there is a hardware change. Most Supervisory functions can only be changed using *password 2* (high level password).

Finally, the CNA-200 provides for storing “Clock Start Times. This can be an extremely useful tool for the projectionist and manager. The CNA-200's internal clock and calendar allows the user to store up to ten clock start times per day for the entire week.

Normal Operation

Normal operation assumes completion of the basic setup of the CNA-200 to perform normal functions. This initial programming should be accomplished as the equipment is installed according to the requirements of the theater by the installing engineers, and can be changed only by Supervisory personnel using a high level password.

A low level password, Password #1 (set by the Supervisor), allows a level of programming for normal operation. Generally, the daily program operation will require only modification of show times or film Format changes that occur with normal changes of feature films. This level of programming is accessed by both password.

It is important to note that the CNA-200 functions in a manner similar to current automation technology in that a prescribed sequences of events are performed at a given input, such as pushing the Start button or sensing of a foil film cue. However, the CNA-200 can perform many more functions in a wide variety of ways, all of which are fully programmable.

Product Description

The CNA-200 Cinema Network Automation System is a microprocessor based computer automations designed to automate all aspects of the theatre presentation. The major features of the CNA-200 are described in the following sections.

Local I/O Network (LIN)

Each CNA-200 system component is connected to the network and communicates via a five wire cable. This cable provides the serial communications as well as power to the termination panels. This is called the "Local I/O Network". The standard devices that make up the system are the:

1. Console Termination Panel
2. Booth Termination Panel
3. Control Panel

The CNA-200 Automation Control Panel contains the main computer which functions as the 'master' of the system and each I/O device is connected to it via a serial communications link. The devices are connected in a daisy-chain method and can then be distributed within the booth according to their logical location.

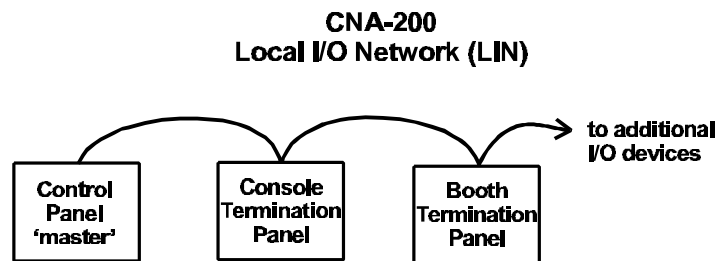

Local Synchronous Network (LSN)

The "Local Synchronous Network" is a two-wire data link that will support CNA-200 and CNA-100 Automations, remote stations, synchronous communications for interlock, network copy functions and a Host PC. The automation systems are connected together in a daisy-chain configuration, which allows the transmission line to continue from one unit to the next.

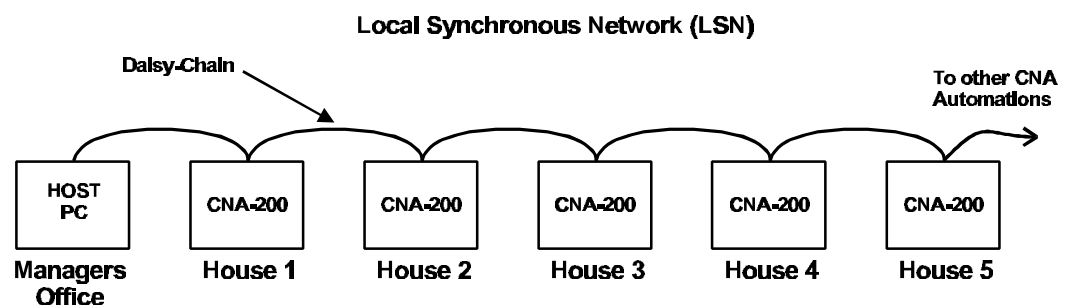

System Components

The standard components that make up the automation system LIN are described in the following sections.

Console Termination Panel

This panel supports the input and output termination interface and provides connections for standard booth functions as listed below:

Outputs:

- Projector Motor; On/Off
- Xenon Lamp; On/Off
- Changeover; Open/Close
- Lens Turret; Flat/Scope/Special
- Auxiliary Output; On/Off

Inputs:

- Film Presence
- Film Motion
- Film Tension
- Cue Input
- Xenon Fault

Features:

- High power *dry* relay contact outputs.
- High power override connector for plug-in cable to override switches.
- Projector motor fuse
- Plug-in control board to handle I/O and serial interface.
- Terminal Blocks for connection to the console equipment

The relays and control board get their power from the network cable. The control board will plug onto the relay board to provide the I/O and network interface.

Booth Termination Panel.

This panel provides the outputs to control the following functions:

Outputs:

- Top Masking; Flat/Scope/Special
- Side Masking; Flat/Scope/Special
- Curtains; Open/Close
- House Lights; Up, Down, Mid 1, Mid 2
- Stage Lights; Up, Down
- Environment; On/Off
- Slide Projector; On/Off
- Sound Processor; Mono, SVA, SR, Digital 1, Digital 2, Aux 1, Aux 2, Nonsync, Mute, Preamp1/Preamp2, Remote Fader

Inputs:

- Remote Start
- Remote Stop

Features:

- Low power dry relay contact outputs.
- High power dry relay contact outputs for Slide Projector and Environment Control
- A plug-in control board to handle I/O and serial interface.
- Override connector for plug-in cable to override switches.
- Override connector for optional override switches.
- Terminal blocks for user interface.

This Panel (PC board) will connect to the to the Local I/O Network (LIN). The outputs will be configured at the CNA-200 Control Panel or PC Host

The relays and plug-in control board get their power from the LIN cable. This board will generally be mounted in a cabinet on the booth wall, but can also be mounted in the console next to the Booth Termination Panel

Control Panel (Operator Interface)

The automation controller and front panel interface is a self-contained unit that can either be surface mounted to the booth wall or can be mounted in a standard 19" rack. The unit will house the main CPU, the front panel interface and the power supply for local and remote power for the Local I/O Network.

Communications to the local I/O devices and other remote CNA-200 systems is accomplished via two serial ports on the Main CPU:

The Local I/O Network Com Port - This is the interface for the Local I/O Network (LIN) that will support the Main I/O Interface, the Console and Booth

Termination Panels and other auxiliary devices.

The Local Synchronous Network Com port - This is the interface for the Interlock and Copy function between CNA-200 systems, Remote Monitors and PC Host.

The control panel is used to setup, program and run the shows. It also displays error and status messages to the user. The control panel incorporates up to nine manual override switches used for emergency manual control. These are rocker switches and their general functions should be obvious to the operator. All manual controls circumvent the electronic circuitry giving the user the ability to control the major functions in the event of an automation failure. The manual control functions are listed below:

1. PROJECTOR - Maintained ON/AUTO
2. LAMP - Maintained
3. CHANGEOVER - Momentary OPEN/CLOSE
4. LENS - Momentary FLAT/SCOPE
5. LENS - Momentary SPECIAL
6. CURTAIN - Momentary OPEN/CLOSE
7. HOUSE LIGHTS - Momentary UP/DOWN
8. STAGE LIGHTS - Momentary UP/DOWN
9. AUXILIARY - Momentary ON1/ON2

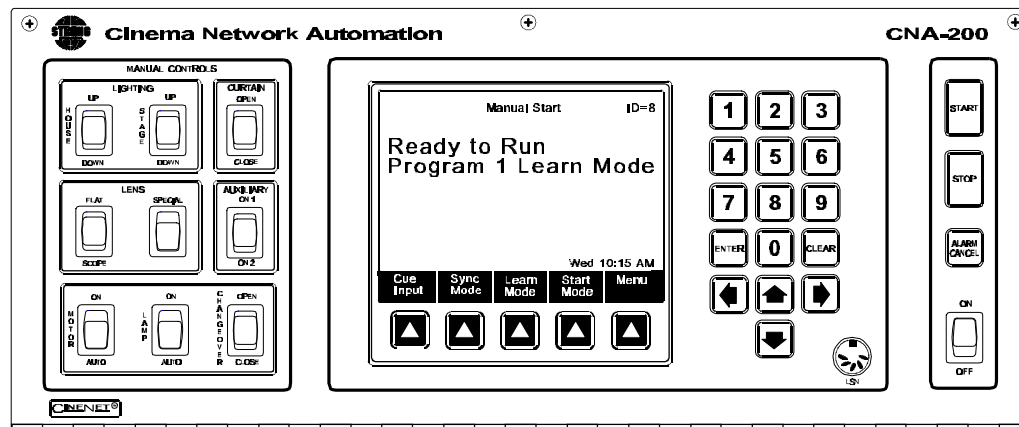

Figure 1.1

To the right are POWER, START, STOP and ALARM CANCEL keys. The programming keypad and display screen make up the remainder of the panel. All programming will be done using the keypad.

The keypad consists of numeric, cursor and *soft* keys. The Display Screen shows the current status of the system in the RUN mode or the data being edited in the SET-UP mode.

POWER - This switch is used to turn the automation on.

STOP - Forces the automation to a stop condition or cancels a timed or clock start operation.

START - This key is used to manually start or restart the presentation which will run the selected program.

ALARM CANCEL - This key will cancel a local and remote alarm. It also serves to clear fault messages displayed on the screen. Pressing the Alarm Cancel key once will cancel the alarm. Pressing the key again will clear the fault condition. (See *System Fault and Status Messages* Section on page 72).

Keypad

The keypad is used for data entry. This is used to set up and program the system. It is also used for selecting the start mode, feature formats, sync enable and cue learn. The function of each key is briefly described below.

ENTER - This key is used to save edited data and move the cursor to the next field to edit.

CLEAR - This key is used to reset a numeric data field to 0.

CURSOR (right, left, up, down) - These keys are used to change screens or fields to view or edit data.

SOFT KEYS - These keys are specific to each screen in the system and will change as you move to different screens.



Figure 1.2

CNA-200 Run Mode Screen

This is the CNA-200 *Run Mode* or *Home* screen. This screen provides the user with information such as Show status, Program number, Cue Learn and Cue number, Sync Mode, Start Mode and film format messages.

Section 2

INSTALLATION

The Installation section of this manual provides detailed wiring diagrams to aid in the installation process. A special section entitled *Installation Guidelines* is included to provide the installer with a set of important rules to follow that will help insure a successful installation.

Equipment Required

The CNA-200 should be installed only by an electrician, engineer or other qualified personnel. No special equipment or tools are required for installation. Typically the CNA-200 main controller and Console termination panel will be mounted in the Strong console and factory pre-wired.

Equipment Inspection

The equipment should be carefully inspected for signs of visible damage resulting from transportation and handling. Please notify the freight carrier immediately if damage is found.

Wiring the CNA-200 System

Remember, during installation to insure that all requirements of national and local electric codes are satisfied. Be sure to run *clean* power (dedicated to the CNA-200 systems only) to all CNA-200 automation systems from the service entrance panel or closest branch panel. The line, neutral and ground wires should all run back to the main service panel (separate from all other loads). It is acceptable and preferred if all automations were run from a single distribution point.

Important Note: Do not connect the projector motors, changeovers, xenon rectifiers or other heavy or noisy loads to this circuit.

Power Supply

Before applying power, verify that the power supply inside the unit is set to the same voltage (120V or 230V) that will be powering the unit. If it is not, move the switch S1 to the appropriate position. To access the power supply, open the front panel by removing the three screws along the top-front of the unit. The power supply board is mounted to the back wall. The switch S1 can be set with a small *flat-blade* screwdriver. Figure 2.1 shows the power supply power terminations and voltage selectors switch.

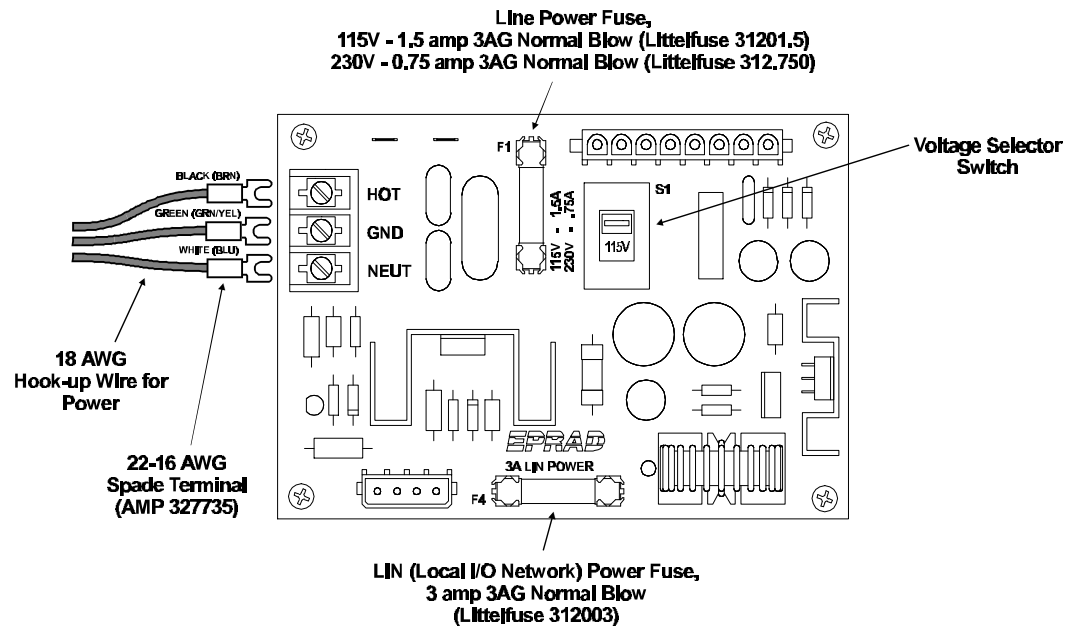

Figure 2.1

There are also two field-replaceable fuses on the power supply board. F1 is the line power fuse and F4 is the LIN (Local I/O Network) power fuse. All units are shipped from the factory with a 1.5 amp line fuse (F1). If 230 volt ac operation is required, it is the responsibility of the installer to change this to a 0.75 amp fuse. (Littelfuse #312.750). Remember, before servicing these fuses, be sure power is removed from the unit.

LSN and LIN Communications Wiring

Wiring between the CNA-200 automations and the Termination boards are shown in figure 2.2. The wiring is accomplished with two communication networks. These are the LIN and LSN.

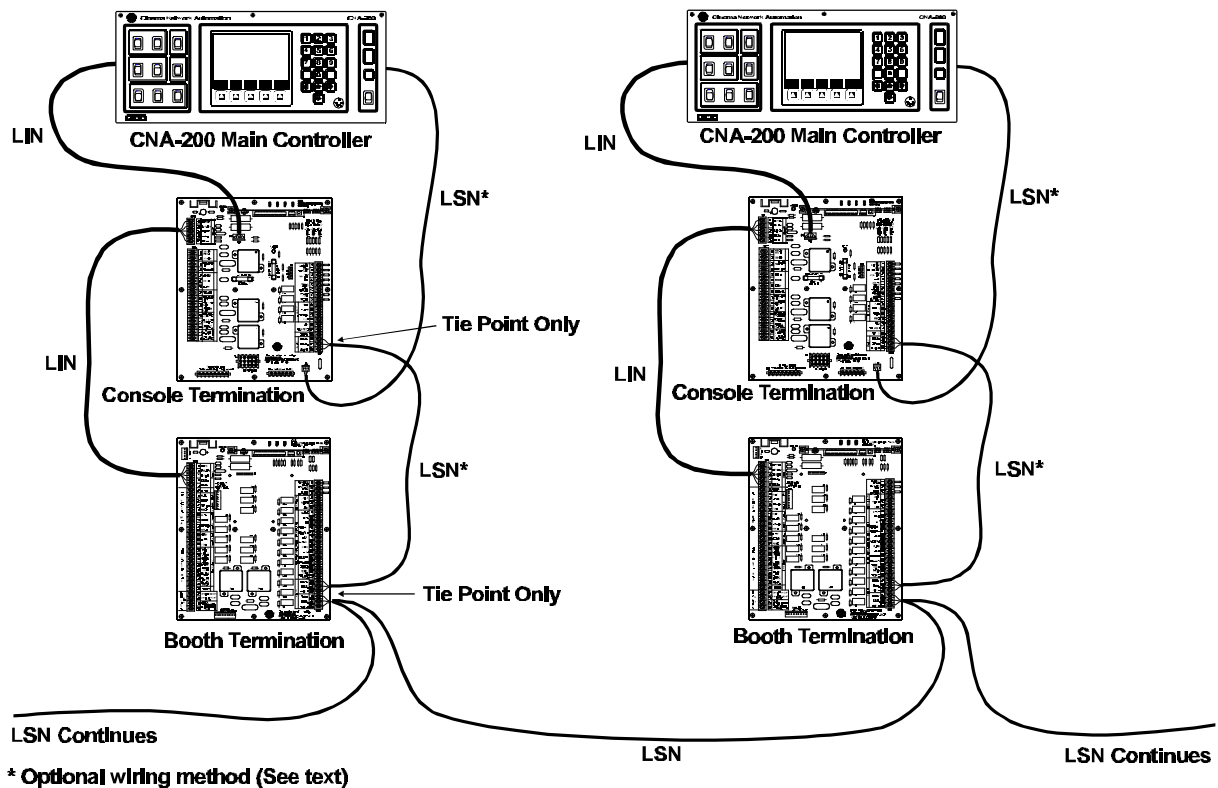

Figure 2.2

The CNA-200 Main Controller controls the Console and Booth termination boards via the LIN (Local I/O Network). This is a five wire cable that provides the serial communications as well as power to the termination panels. The termination boards are connected in a *daisy-chain* method and are mounted in the booth according to their logical location. For example, the Console termination board would typically be mounted in the console or on the pedestal, and the Booth termination board could be mounted on the wall.

LIN cable specifications: 2 twisted pair, 18 AWG with overall shield and drain wire (Alpha #5132C or equivalent).

Communication wiring between CNA-200 systems is accomplished via the LSN (Local Sync Network). The LSN provides a communications path between the CNA-200s, Remote Monitors and a PC host. The network supports synchronous communications for interlock, copy functions and remote status and control.

Figure 4 shows the LSN cable wired between the main controller and termination boards. The connections on the termination boards are tie points only, that provide a path to the main controller. It will typically be more convenient for the installer to connect CNA-200 systems together at the Booth termination board.

The cable is 2 conductor, twisted pair with a shield. Wire gage is dependent on the length of wire needed. In general, 24 AWG is sufficient. Many cable manufactures offer a broad range of 120-ohm cables designed for RS-485 applications.

LSN cable specifications: Twisted pair, 24 AWG with overall shield and drain wire (Alpha #6412, Belden #9841 or equivalent).

When planning the communications wiring, keep the cable away from equipment that generates electrical noise, such as power conduits, fluorescent lighting fixtures, air conditioners, etc. Choose cable routing paths in such a way to prevent damage to the cable.

The required method for communication wiring of the LSN and LIN is the daisy-chain configuration, a system in which the transmission line continues from one unit to the next. See figure 2.3 for the daisy chain connection topology. The bus must form a continuous path. Devices must not be branched or spoked.

Correct Wiring Technique

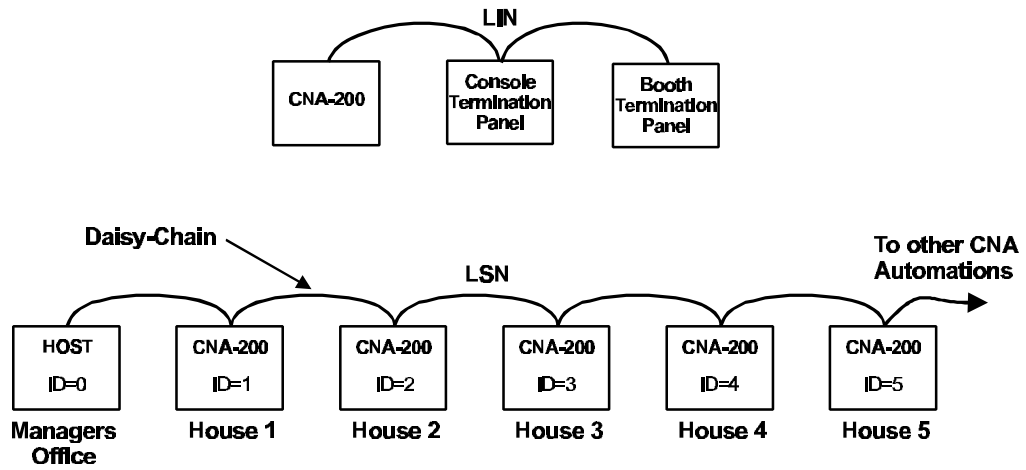

(a) Correct - The optimal configuration for the RS-485 bus is the daisy-chain connection.

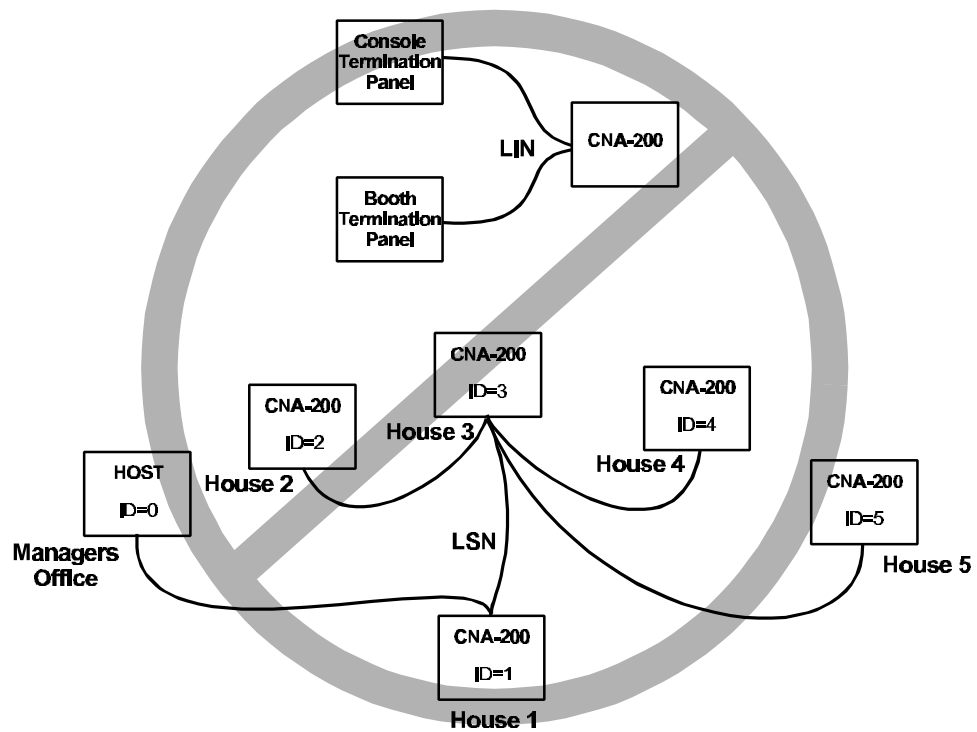

(b) Incorrect - This may create transmission line problems. Must be Daisy-Chained, not branched or home run.

Figure 2.3

Normally it won't be necessary to wire to the CNA main board (It will be wired at the factory). The installer will wire the LSN and LIN communication cables to the Booth or Console termination board. But, if it becomes necessary to wire directly to the 39325 Main Board, figure 2.4 shows how to terminate the wires.

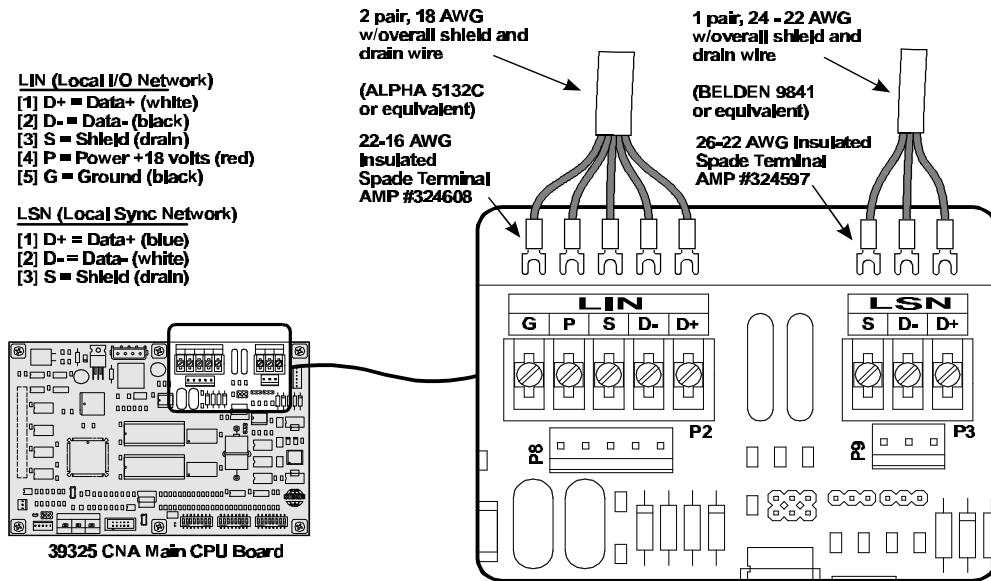

Figure 2.4

The LSN and LIN cables that connect the main board to the console termination board are shown in figure 2.5.

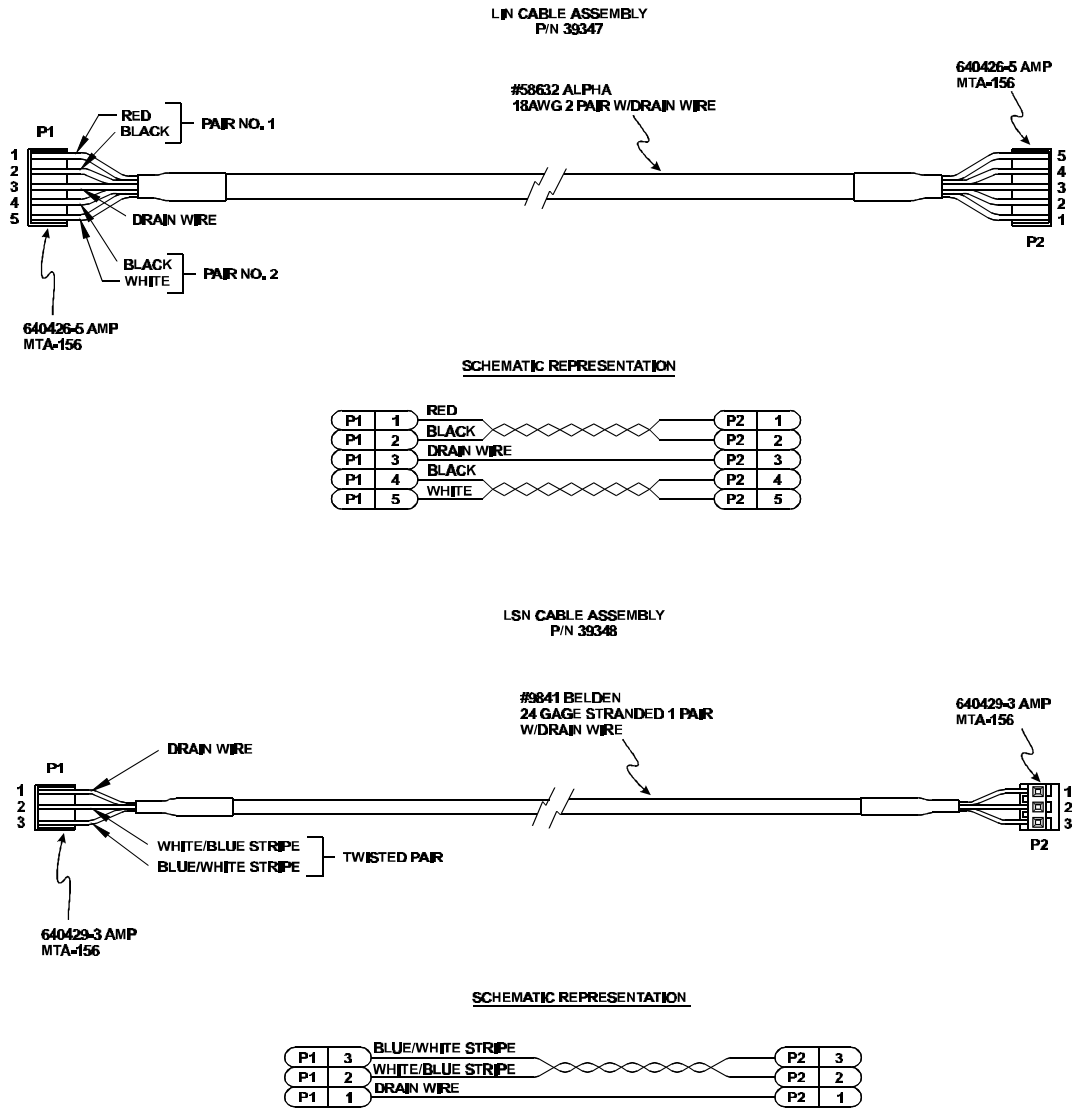

Figure 2.5

Termination Boards

All booth and auditorium devices (xenon lamp, projector motor, lights, etc.) are wired to the 39330 Console Termination Board and the 39331 Booth Termination Board. The Console Termination Board is shown in figure 2.6.

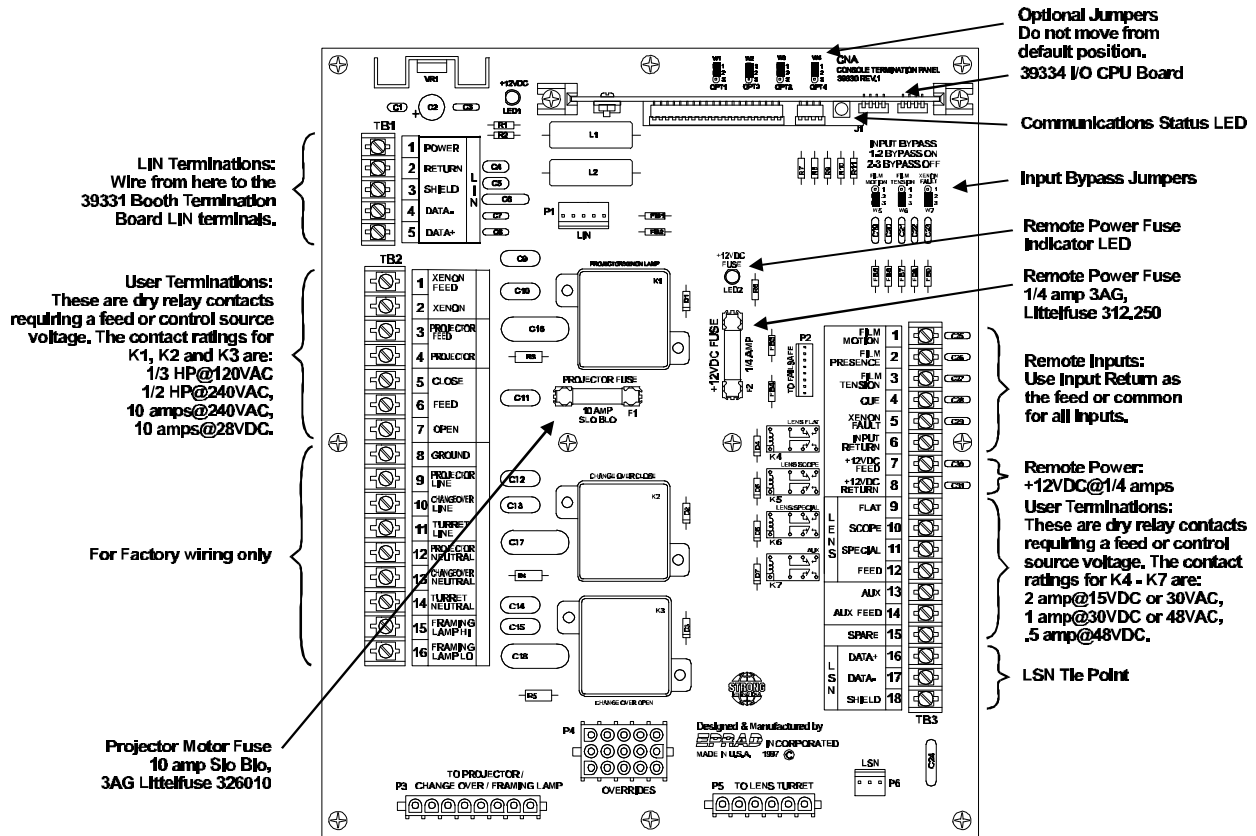

Figure 2.6

The 39334 I/O CPU Board plugs into the J1 connector on both termination boards. The purpose of this board is to handle the communications to and from the CNA-200 Main Board and to control the inputs and outputs. The Status LED on this board indicates the following:

Fast Blinking Rate: The I/O CPU computer is working and is communicating properly with the CNA-200 Main Board (Master).

1 Blink On, Pause: The I/O CPU computer is waiting for data from the Master, and the I/O is disabled.

2 Blinks On, Pause: Communications Timeout, I/O is disabled.

The Booth Termination Board is shown in figure 2.7.

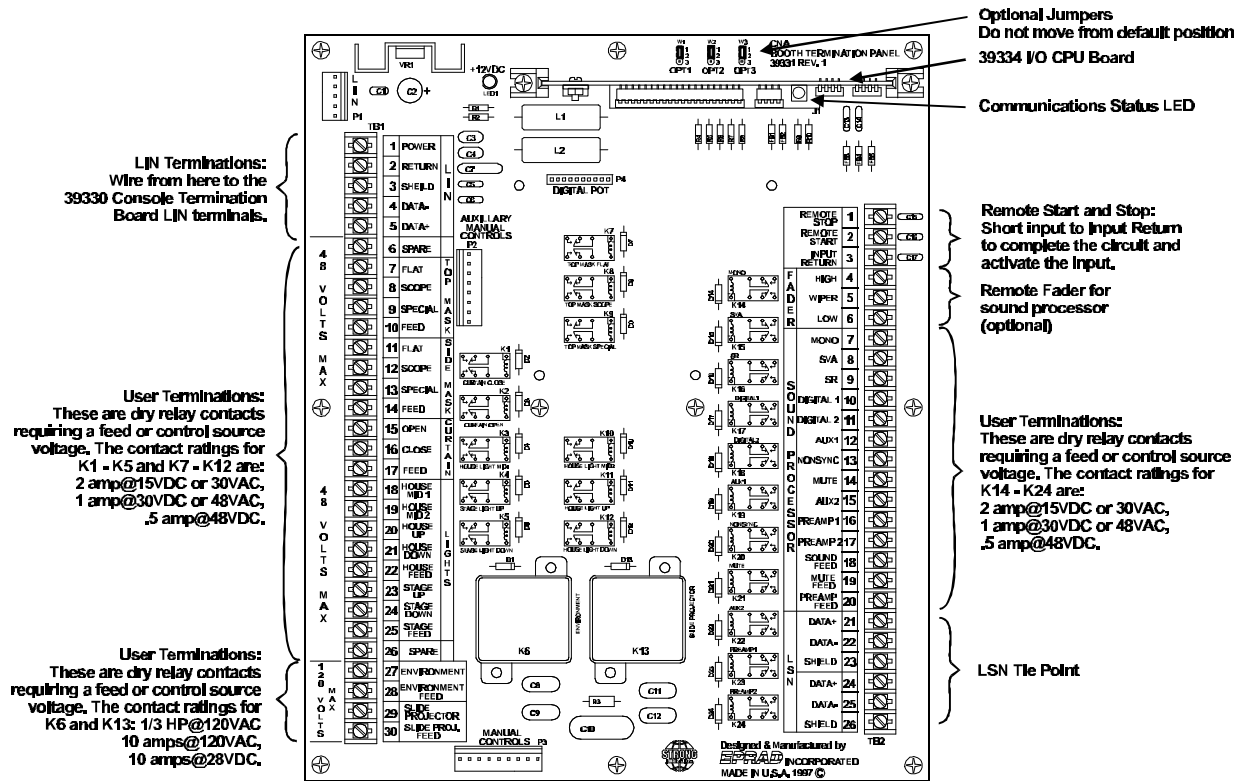

Figure 2.7

BTC-10 Booth Termination Cabinet

The Booth Termination board can be mounted in the console or optionally in a wall mount cabinet. The BTC-10 wall cabinet can be delivered to the job site early allowing the electrician to pre-wire the curtains, masking motors, LSN (Sync Network), light dimmer and sound processor. The BTC-10 is available with optional manual override switches.

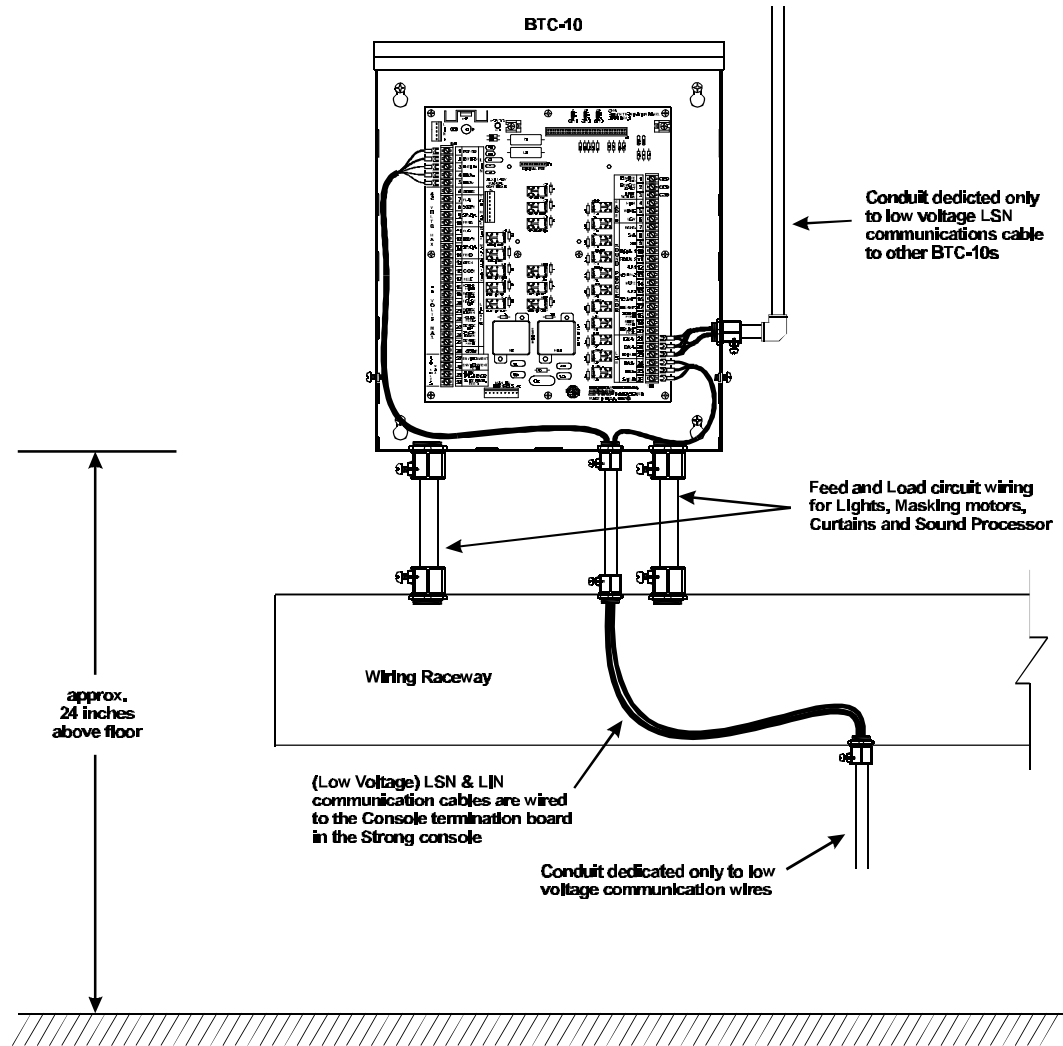

Figure 2.8

Figure 2.8 shows a typical BTC-10 installation. The internal connections required for LSN and LIN communications cables are also shown. The LIN and one LSN cable is wired to the Console termination board in the Strong Console. Keep all LSN and LIN cables separated from high voltage and electrically noisy wiring by running them in conduit dedicated to low voltage communication wires.

The cabinet is constructed of 16 gage steel measuring 16-1/2 inches high by 14 inches wide by 3-1/2 inches deep. The four mounting holes are keyholes capable of accepting 1/4-20 bolts or screws with a maximum head diameter of 7/16 inch.

Begin by locating the four keyhole centerlines on the wall. Install the appropriate wall anchors and turn the fasteners until 1/4 inch is left between the head and wall. It is recommended that the top of the BTC-10 not exceed 46" from the floor for proper viewing and operation of the control panel. Hang the cabinet on the four fasteners and secure it by tightening the fasteners.

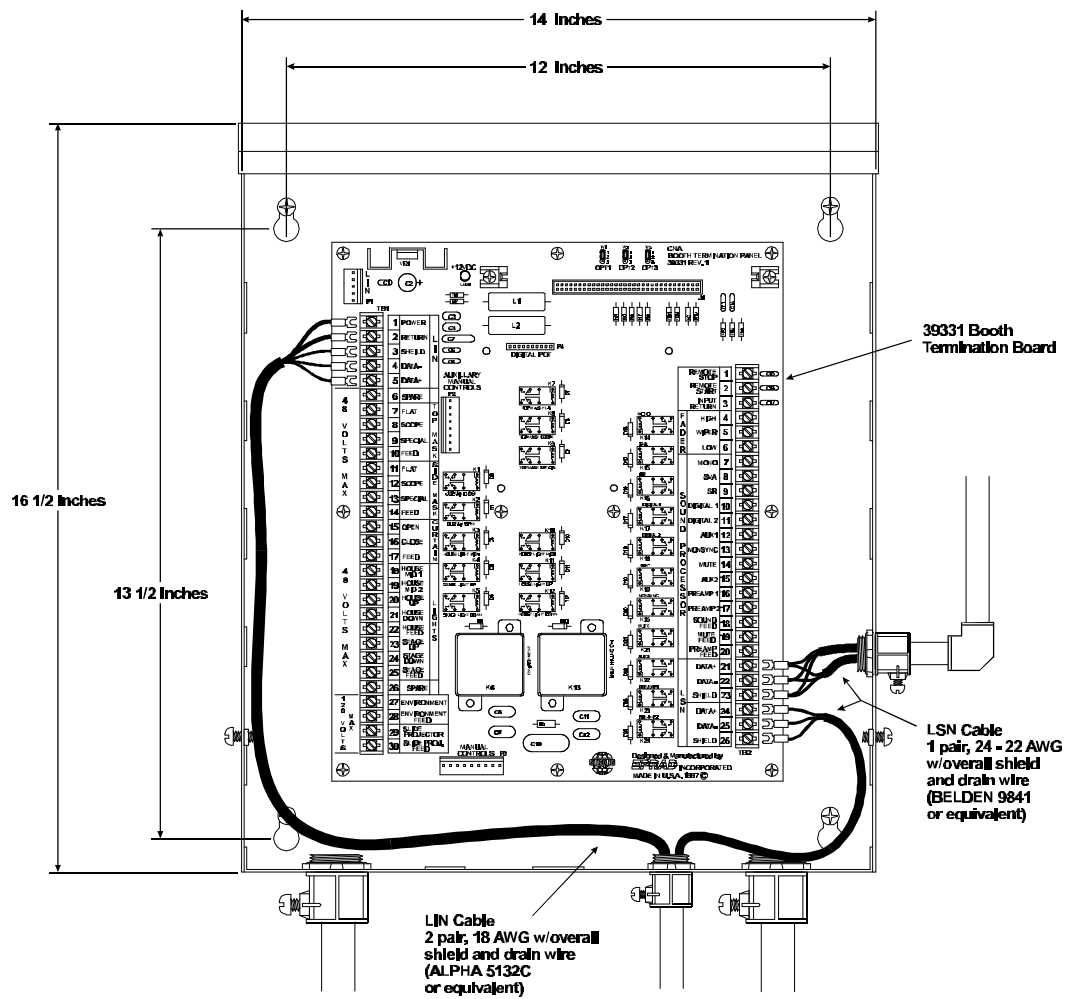
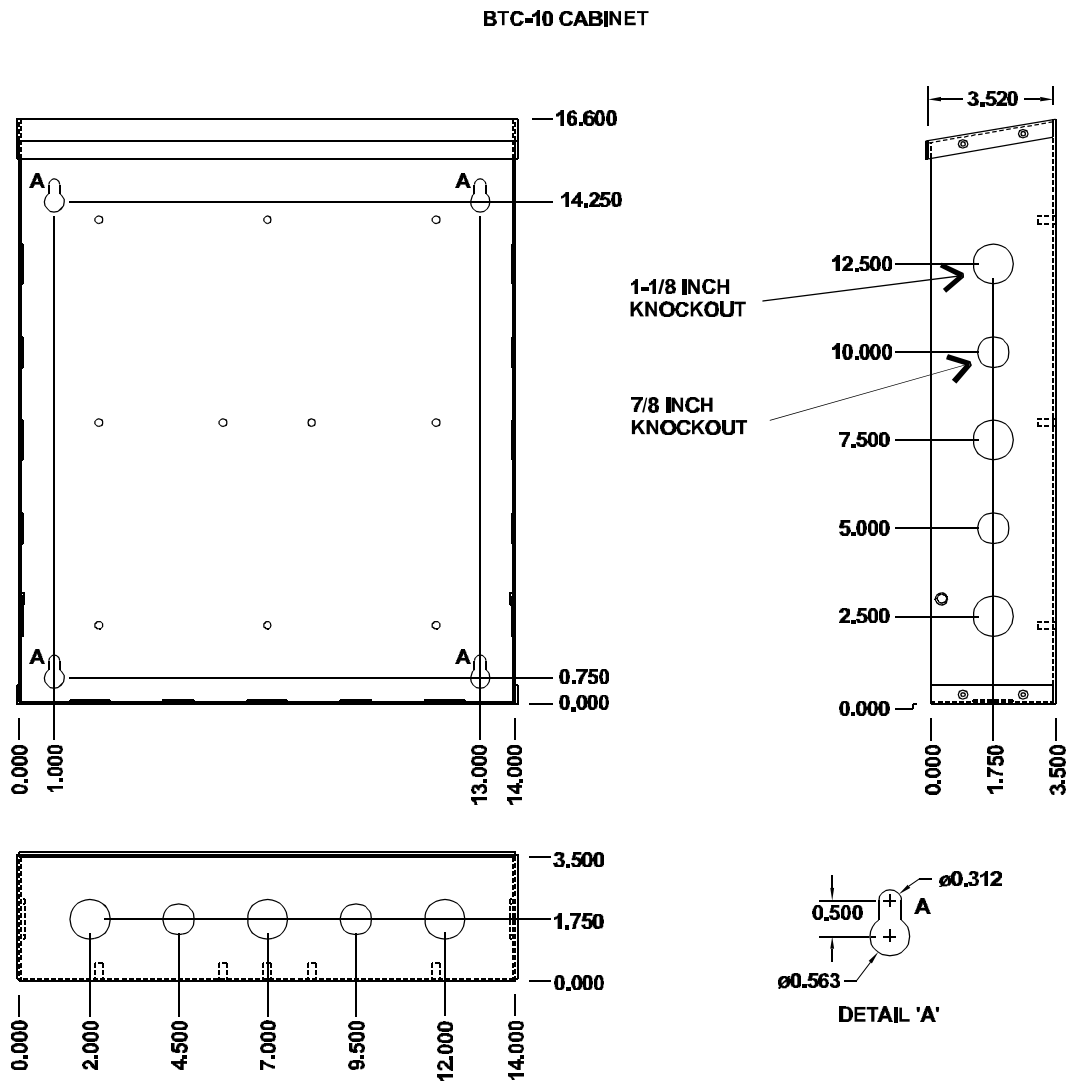

Figure 2.9

7/8 inch and 1-1/8 inch knockouts are provided on the bottom and both sides of the cabinet. Prepare the cabinet for wiring by removing the desired knockouts.



NOTES:
MATERIAL: 16 GAUGE COLD ROLLED STEEL
FINISH: BLACK POWDER COAT; MEDIUM TEXTURE

Figure 2.10

The BTC-10 provides (optional) override switches for masking, curtains and auditorium lights. Two auxiliary switches can be installed and their function can be determined by the installer. The auxiliary switches can be either momentary or maintained contact. The momentary switches are rated for 6 amps @ 120 vac and the maintained switches are rated for 16 amps @ 120 vac.

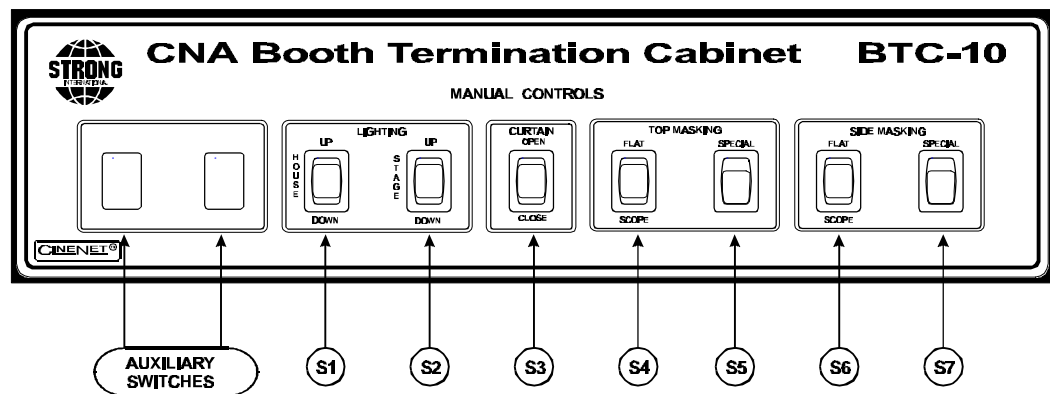

Figure 2.11

- S1 - House Lights UP/DOWN
- S2 - Stage Lights UP/DOWN
- S3 - Curtains OPEN/CLOSE
- S4 - Top Masking FLAT/SCOPE
- S5 - Top Masking SPECIAL
- S6 - Side Masking FLAT/SCOPE
- S7 - Side Masking SPECIAL

Available (standard) Configurations:

| | |
|------------------|---|
| Part No. 39340 | BTC-10 with no switches |
| Part No. 39340-1 | BTC-10 with S1, S2 & S3 |
| Part No. 39340-2 | BTC-10 with S1, S2, S3, S4, S5, S6 & S7 |
| Part No. 39340-3 | BTC-10 with S4, S5, S6 & S7 |

Order auxiliary switches separately.

The manual override cable assembly drawings are shown in Figure 2.12. The 39344 and the 39345 cable assemblies may also be ordered separately.

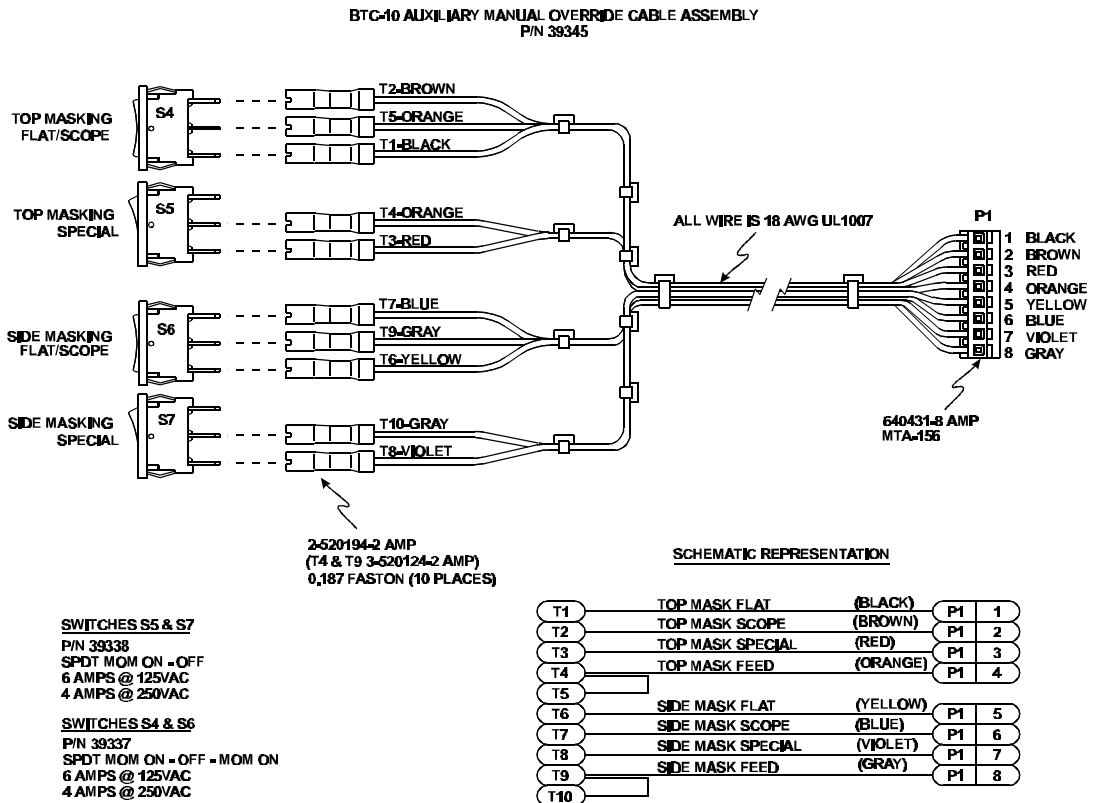
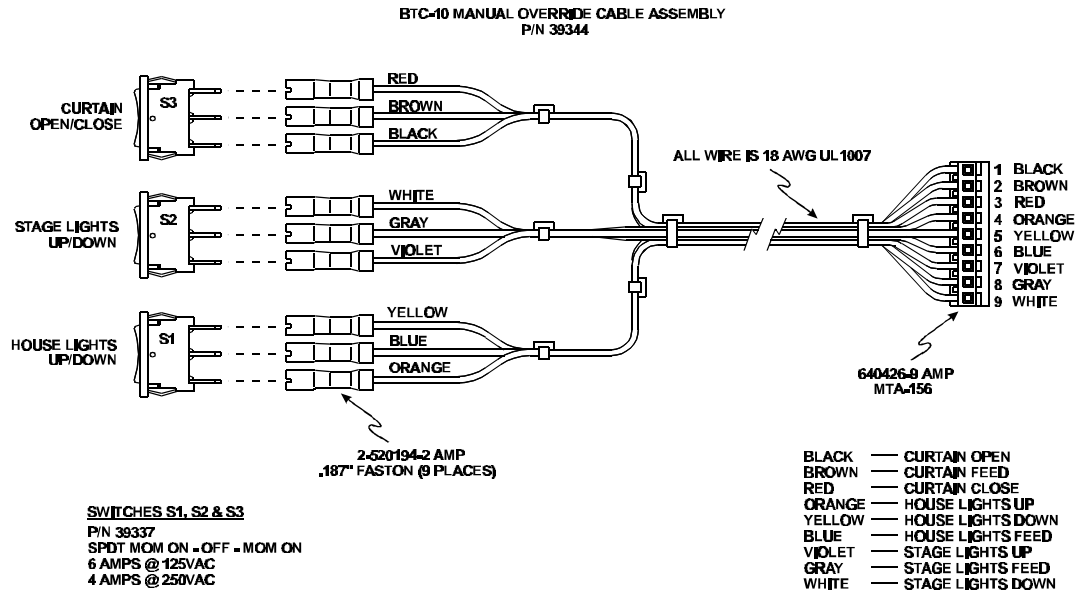

Figure 2.12

Configuring the System

The LSN can support up to 64 devices (CNA-200s, CNA-100s, Remote Status Monitors and a Host Computer). **Each device will each require a unique Sync Id number.** Id 0 is reserved for the *Host PC* and Ids 1 through 63 are assigned to CNA-200s and other devices as necessary. To keep things simple, assign the CNA-200 Ids starting at 1, corresponding to the house number and working up. The Remote Monitor's Ids, if used, should be assigned to the higher numbers starting at 62 and working down. You may want to keep Id 63 reserved for the portable or *secondary* host.

To set the Id number, first locate the eight position dip switch designated SW1. See figure 2-13.

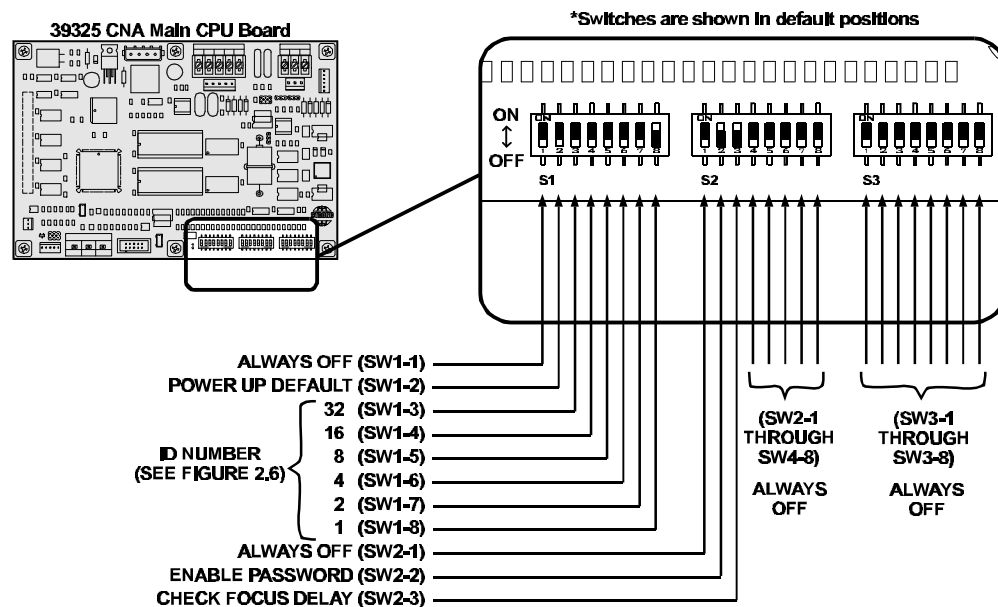

Figure 2.13

Switch Definitions

- SW1-1 This switch is reserved for future use. (Force Bootloader)
- SW1-2 ON will force Supervisory “Default” values on power up. This switch should normally be OFF.
- SW1-3 through SW1-8 ID Number (See Figure 2.14)

Use the table to configure the CNA-200s Id number with switches S1-3 through S1-8.

| | | | |
|-------------------------------------|-------------------------------------|-------------------------------------|-------------------------------------|
| | ID = 16 ON ↓ OFF ↑ | ID = 32 ON ↓ OFF ↑ | ID = 48 ON ↓ OFF ↑ |
| ID = 1 ON ↓ OFF ↑ | ID = 17 ON ↓ OFF ↑ | ID = 33 ON ↓ OFF ↑ | ID = 49 ON ↓ OFF ↑ |
| ID = 2 ON ↓ OFF ↑ | ID = 18 ON ↓ OFF ↑ | ID = 34 ON ↓ OFF ↑ | ID = 50 ON ↓ OFF ↑ |
| ID = 3 ON ↓ OFF ↑ | ID = 19 ON ↓ OFF ↑ | ID = 35 ON ↓ OFF ↑ | ID = 51 ON ↓ OFF ↑ |
| ID = 4 ON ↓ OFF ↑ | ID = 20 ON ↓ OFF ↑ | ID = 36 ON ↓ OFF ↑ | ID = 52 ON ↓ OFF ↑ |
| ID = 5 ON ↓ OFF ↑ | ID = 21 ON ↓ OFF ↑ | ID = 37 ON ↓ OFF ↑ | ID = 53 ON ↓ OFF ↑ |
| ID = 6 ON ↓ OFF ↑ | ID = 22 ON ↓ OFF ↑ | ID = 38 ON ↓ OFF ↑ | ID = 54 ON ↓ OFF ↑ |
| ID = 7 ON ↓ OFF ↑ | ID = 23 ON ↓ OFF ↑ | ID = 39 ON ↓ OFF ↑ | ID = 55 ON ↓ OFF ↑ |
| ID = 8 ON ↓ OFF ↑ | ID = 24 ON ↓ OFF ↑ | ID = 40 ON ↓ OFF ↑ | ID = 56 ON ↓ OFF ↑ |
| ID = 9 ON ↓ OFF ↑ | ID = 25 ON ↓ OFF ↑ | ID = 41 ON ↓ OFF ↑ | ID = 57 ON ↓ OFF ↑ |
| ID = 10 ON ↓ OFF ↑ | ID = 26 ON ↓ OFF ↑ | ID = 42 ON ↓ OFF ↑ | ID = 58 ON ↓ OFF ↑ |
| ID = 11 ON ↓ OFF ↑ | ID = 27 ON ↓ OFF ↑ | ID = 43 ON ↓ OFF ↑ | ID = 59 ON ↓ OFF ↑ |
| ID = 12 ON ↓ OFF ↑ | ID = 28 ON ↓ OFF ↑ | ID = 44 ON ↓ OFF ↑ | ID = 60 ON ↓ OFF ↑ |
| ID = 13 ON ↓ OFF ↑ | ID = 29 ON ↓ OFF ↑ | ID = 45 ON ↓ OFF ↑ | ID = 61 ON ↓ OFF ↑ |
| ID = 14 ON ↓ OFF ↑ | ID = 30 ON ↓ OFF ↑ | ID = 46 ON ↓ OFF ↑ | ID = 62 ON ↓ OFF ↑ |
| ID = 15 ON ↓ OFF ↑ | ID = 31 ON ↓ OFF ↑ | ID = 47 ON ↓ OFF ↑ | ID = 63 ON ↓ OFF ↑ |

Figure 2.14

- SW2-1 This switch is reserved for future use. (Undefined)
- SW2-2 ON will enable the password function that requires the user to input a password to gain access to certain operations.
- SW2-3 ON will enable the Check Focus Delay feature which sounds the alarm to alert the operator that the show is about to start.

Alarm Loudness setting

The alarm loudness can be set for one of three intensities; LOW (87 dBA), MEDIUM (94 dBA), HIGH (98 dBA). See figure 2.15 below.

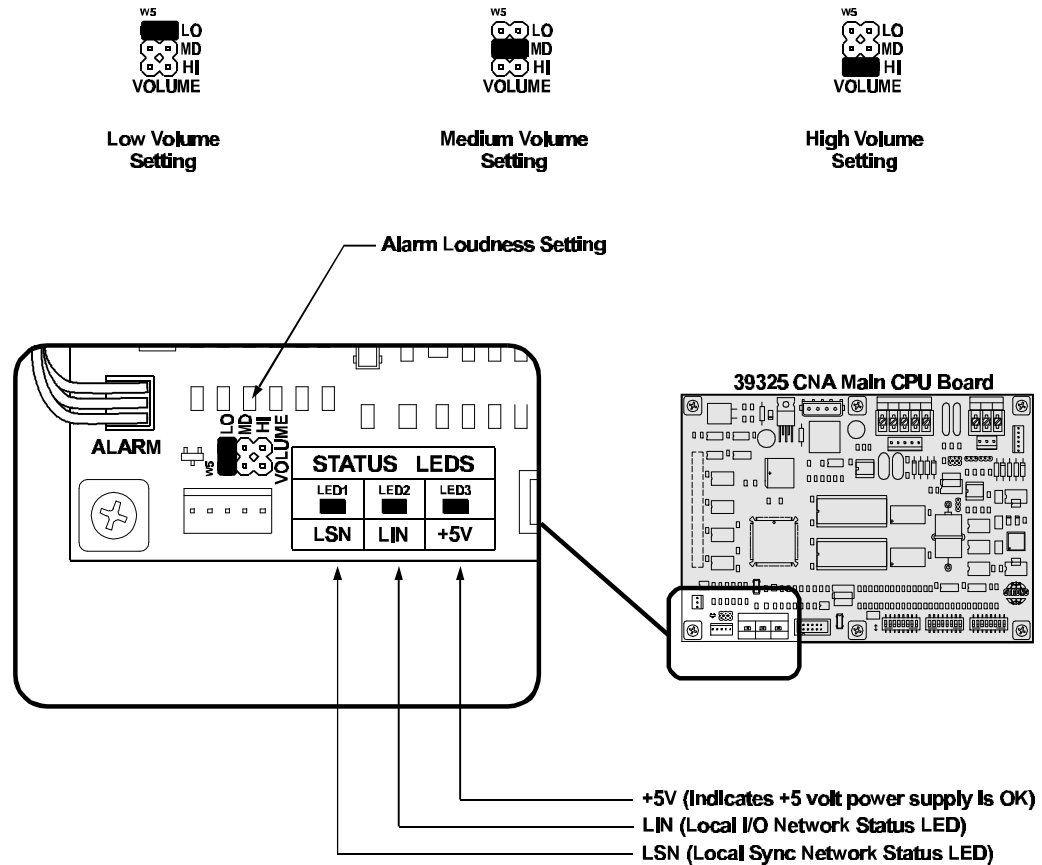

Figure 2.15

Status LEDs

There are three status LEDs on the 39325 Main CPU Board. These indicate the status of the +5 volt power supply, the LSN and the LIN. Following are the three conditions for the LIN and LSN LEDs:

Fast Blinking Rate: The CNA-200 computer is working and is communicating properly.

Slow Blinking Rate: The CNA-200 computer is working, but is *not* communicating.

Off: The CNA-200 computer has a problem.

Battery

Be sure the battery is seated properly in the sockets and the battery jumper W4 is in the ON position.

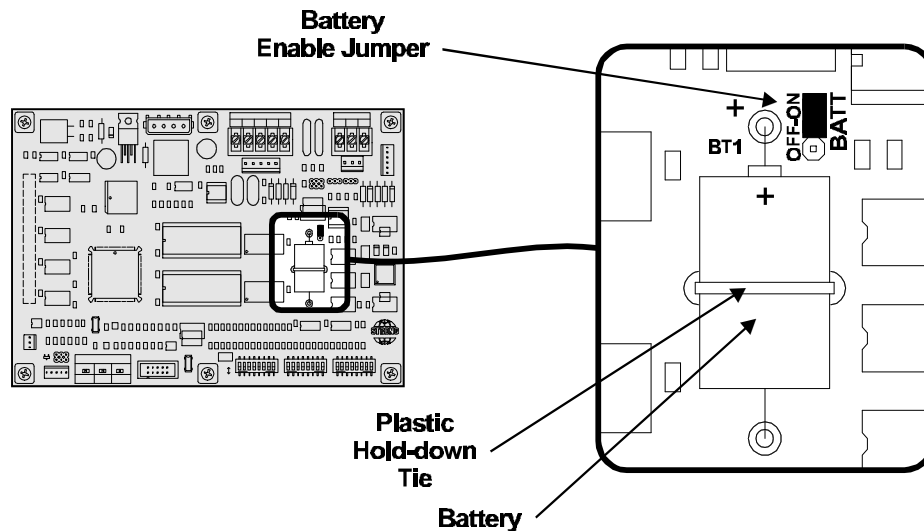
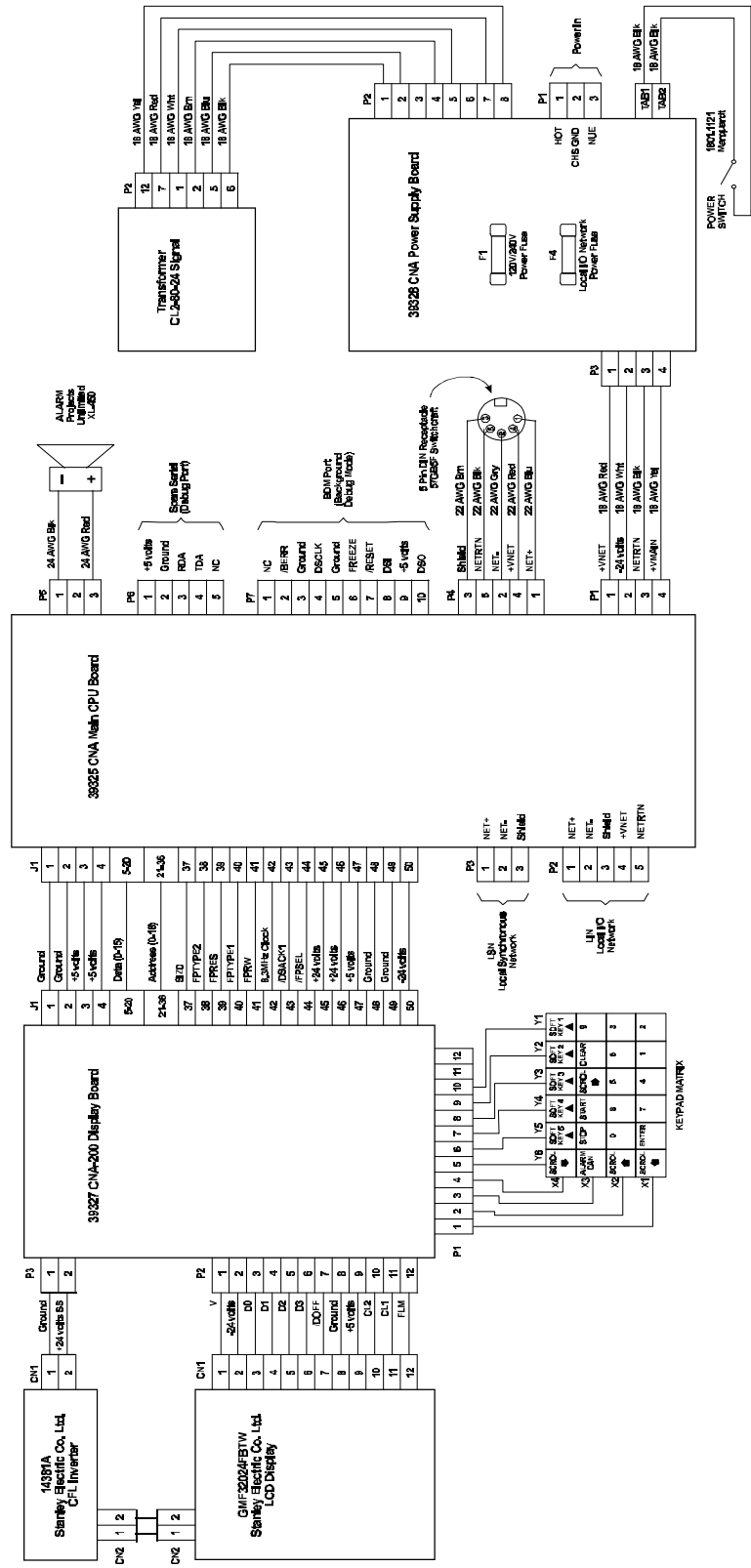

Figure 2.16

Display Adjust

The Display Screen can be adjusted to provide the best viewing angle. Open the front door on the CNA-200 and find the blue potentiometer. Turn the pot with a small flat blade screwdriver until the desired viewing angle is achieved.



38325 CNA-200 AUTOMATION Wiring Diagram

Installation Guidelines

The CNA-200 automation system is a microprocessor based theatre automation. Field installations over the past several years have indicated that common wiring practices vary by region and by installation. For this reason, a set of guidelines which will assist with the successful installation of the CNA-200 is listed below.

Microcomputers by their very nature, are susceptible to noise and power supply fluctuations. While the CNA-200 was designed to function in a noisy environment and survive poor installations, it is to the benefit to the end user that these guidelines be followed.

The items listed below are the result of 25 years of industrial experience and are common, accepted practice for the installation of industrial microcomputers. The cost of implementing is minimal while their benefit is immeasurable.

1. Inspect the product for shipping damage immediately upon receipt. In the event of damage, file a claim with the carrier immediately.
2. Verify that all the relays are seated in their sockets and that all cables are firmly attached.
3. Verify the proper jumper and DIP switch configurations.
4. Verify that the power supply is set for the correct line voltage.
5. Insure that all requirements of national and local electrical codes are satisfied during installation. Run *clean* power (dedicated to the CNA-200 systems only) to all automations from the service entrance panel or the closest branch panel. The line, neutral and ground wires should all run back to the main service panel (separate from all other loads). It is acceptable and preferred and preferred if all automations were run from a single distribution point.

IMPORTANT NOTE: Do not connect the projector motors, changeovers, xenon rectifiers or other heavy or noisy loads to this circuit.

6. It is imperative that the automation have a **good ground**. This is important in terms of safety and performance. The automation has an interference filter for the AC inputs. The specific intent of the filter is to reduce the effect of interference (noise) on the AC line that provides power to the unit, by providing a “leakage” path to ground from the power lines.

Important note: Unless an earth ground is provided this leakage can pose an

electrical shock hazard.

In new installations use a copper conductor (not the conduit) from the automation back to the service entrance ground. Connect all automations in the booth to this ground point. This arrangement is best and most reliable. If this is not practical, (such as a retrofit for example), provide the best “earth” ground possible.

A second best setup would be to run copper wire back to the ground lug in a branch panel.

The minimum acceptable grounding method is conduit ground back to the branch box. In some installations satisfactory operation with this ground may not be possible.

7. Do not run the line voltage power wires in the same raceways as the low voltage signal wires. This is important from both a safety standpoint and a system reliability standpoint. It is best to keep the failsafe, cue detector, LIN, LSN, sound format and dimmer control wires separate from projector motor, changeover, xenon lamp, and other power carrying wires. If it is essential that they be run in the same duct, keep them separated in the duct.

Section 3

SETUP

Introduction

STOP - Please note at this point you should have completed the entire installation of the automation system. If you have not, go to the *Installation* section of the manual and complete it before proceeding.

This section describes how to setup and customize the system to meet the specific requirements of the theatre. The initial setup will be performed by the installing engineers and can be changed only by Supervisory personnel using the high level password. A low level password allows a lower level of programming for daily operations. Generally, the day-to-day operation will require only modification of show start times or film *format* changes that occur with normal changes of feature films.

The specific topics covered in this section are as follows:

- Power up Screen
 - Set-up Menu
 - Set-up Supervisory
 - Set-up Programs
 - Set-up Cue Learn Times
 - Set-up Clock Start Times
 - Copy Functions
 - Local Copy
 - Network Copy
 - Network Status Screens
-
-

Power Up Screen

Apply power to the system. The screen will display the following power-up message:

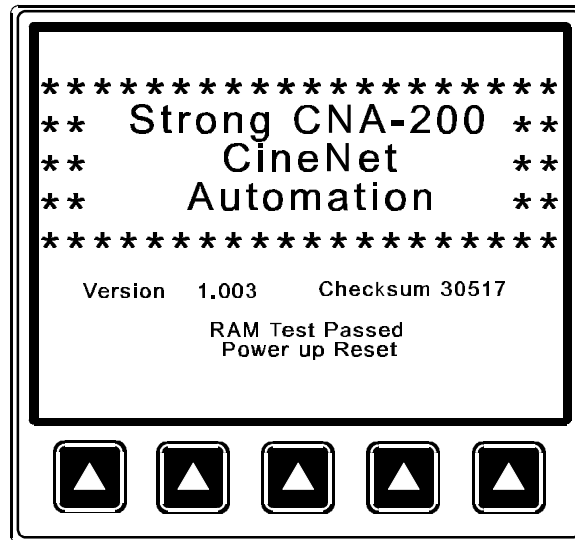

Figure 3.1

This message is displayed for five seconds each time the system is powered up. This screen indicates the software version number (i.e. Version 1.003) and the checksum number (i.e. Checksum 30517). The Checksum number is the arithmetic sum of the contents of the *firmware*, which is calculated upon each power up. This number should be recorded and posted for future reference. If this number changes, see the *Troubleshooting* section in the *Appendix*.

Also on power up, a general purpose RAM test is performed to check the integrity of the system memory. The “RAM Test Passed” message indicates the memory is OK. There are several different methods by which the computer can be reset (or rebooted). The last message on this screen indicates the type of reset that occurred. The message “Power up Reset” is displayed each time the unit is powered up. If you see a message that is different than this, contact the factory.

Figure 3.2 shows the main screen, or the *Run Mode* screen. This screen will display run-time information during and between shows providing the user with critical feedback of show progress, film format, interlock status and fault conditions. From this screen the operator can activate or change modes of operation such as *start*, *sync* and *cue learn* mode. The *Run Mode* screen is explained in detail in the *Operation* section of the manual.

The lower section of the display is dedicated to defining the *softkeys*. These keys

will change as you move to different screens in the system. The keypad to the right of the display will generally be used for entering numeric data and scrolling fields and screens.

To begin the system setup, press the MENU key.

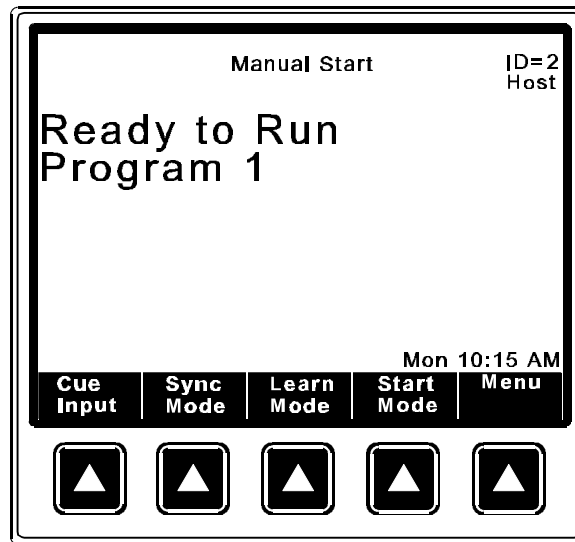

Figure 3.2

This is the Main Menu screen. Here, you select the function or *sub-menu*.

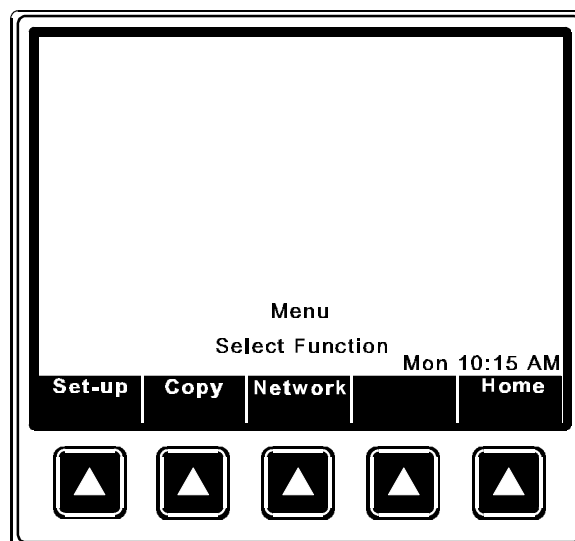

Figure 3.3

Following is a diagram showing the hierarchy of the screens you can access from the Main Menu.

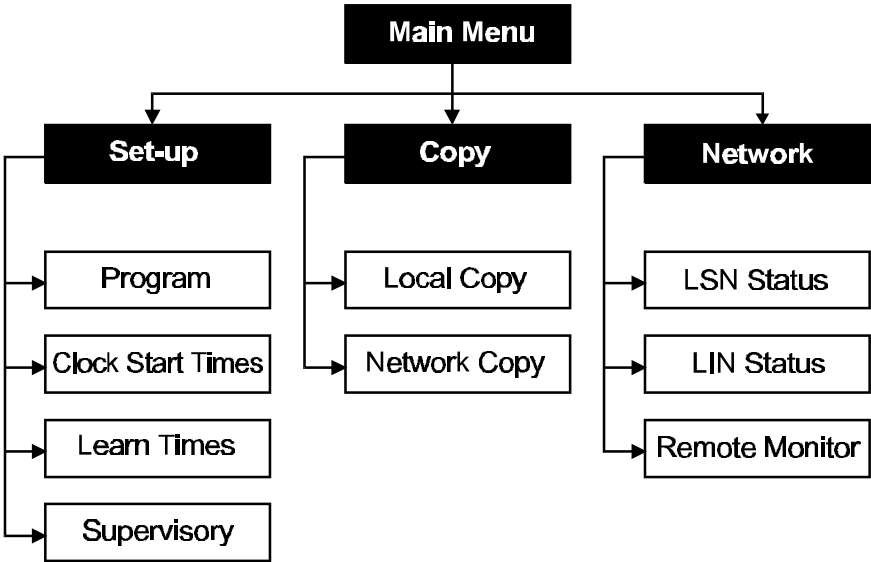

Figure 3.4

Set-up Supervisory

Supervisory is a set of system functions including relay contact configurations, power up states, maintenance schedules, interlock configurations and other system parameters. Supervisory allows the installation engineer to completely configure the system to support the booth's peripheral equipment.

From the main Menu, press the [Set-up Super] key to enter the Supervisory screen.

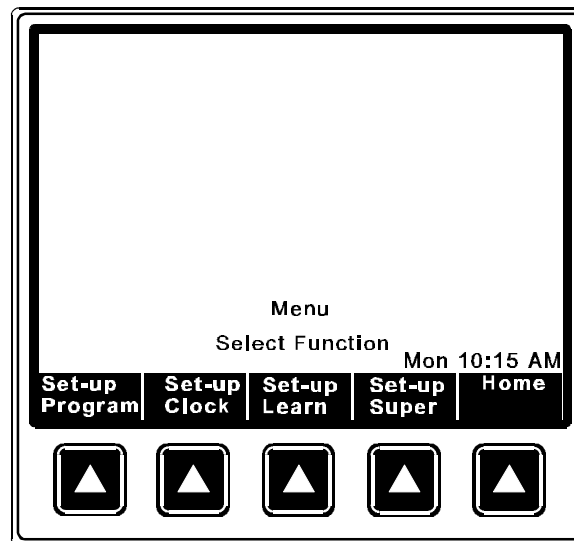

Figure 3.5

At this point you will need to enter the *high level* password to get full access to all Supervisory functions. (Entering the *low level* password at this screen will provide limited access.)

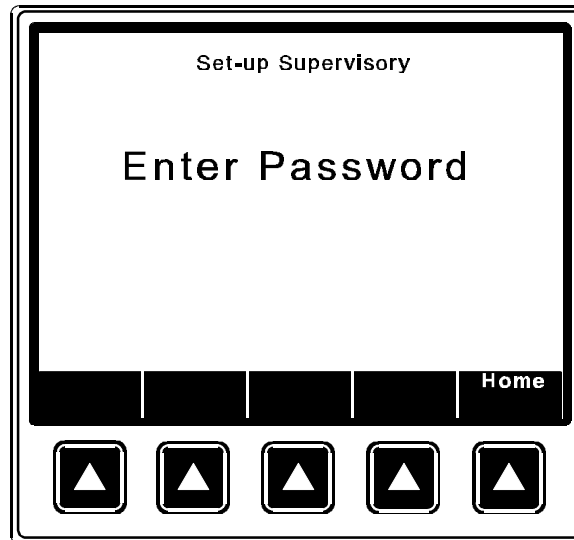

Figure 3.6

There are three Supervisory screens that display the system set-up parameters. Use the [Prev Page] and [Next Page] softkeys to move to the different screens. Use the *cursor* keys to move to different fields within each screen. The cursor will highlight the field to be edited. Edit the fields with the number keys or the [Select Message] softkey. Moving to the next field with either the cursor keys or the *Enter* key will save the data in the previous field.

The first Supervisory screen is shown below.

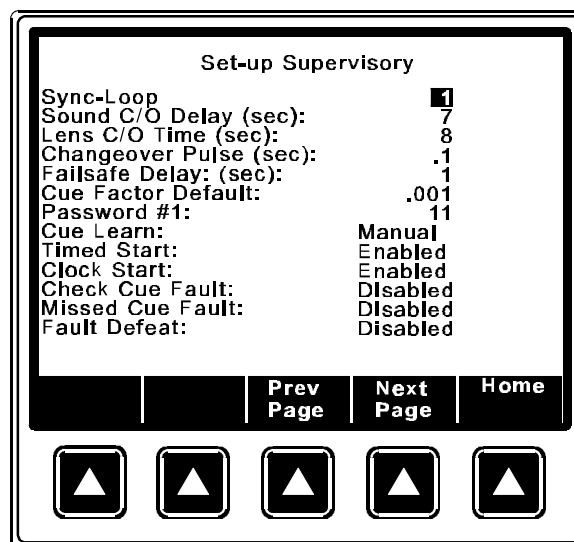

Figure 3.7

Press the [Next Page] key to get to the second Supervisory screen. This is used to display accumulated Run Hours, Set Maintenance Schedules, Time of Day, date and 12 or 24 hour Time Format.

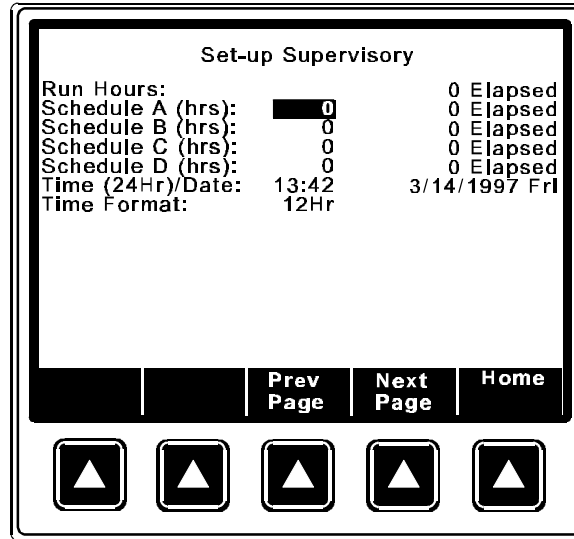

Figure 3.8

Press the [Next Page] key again to get to the third and last screen. Use *up*, *down*, *right* and *left* cursor keys to move to the desired field. This screen is used to configure the outputs. You can customize the relay *Contacts*, *Power-up* and *Fault-to* states.

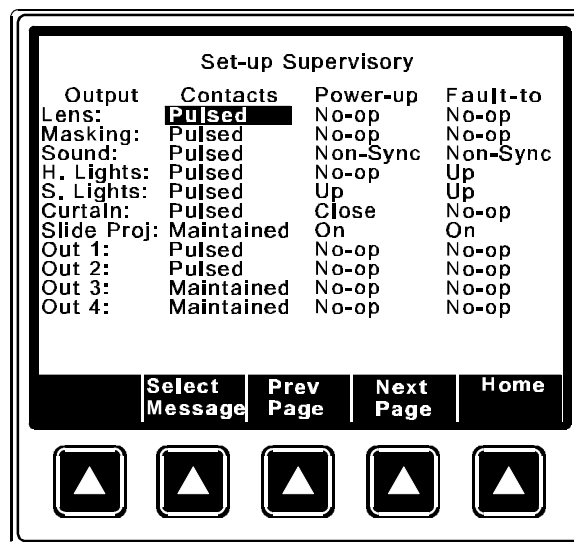

Figure 3.9

Press the [Prev Page] key to go back to the previous Supervisory screens.

When editing the *numeric* data fields, there may be values that are out of range. If you enter an out range value and then try to move to the next field, the screen will display either a **DATA RANGE TOO HIGH** or **DATA RANGE TOO LOW** message. Entering a legal value will clear the message, and allow you to move to the next field.

The following is a list of Supervisory functions and definitions.

8. **Sync Loop:** 1

The CNA-200 automation *Synchronous Network* is capable of supporting up to twenty (20) sync loops at one time. The Sync Loop number assigns the automation to one of twenty sync loops. This function can be accessed with either password. Legal entries are 0 through 20. 0 disables the system from the *Local Synchronous Network (LSN)* and synchronous operation. Enter the data with the number keys.

9. **Sound C/O Delay (sec):** 3

The sound changeover delay determines the delay time between the show start input and the sound changeover from the *non-sync* music source. For example, with the Sound C/O Delay set at 5, five seconds after the show starts the changeover will open. And five seconds after the last (end of show) cue is encountered the changeover will close. The legal range is 3 to 59 seconds. Enter data with the number keys.

10. **Lens C/O Delay (sec):** 5

This represents the time required for the lens turret to change positions from flat to scope. It is the time the changeover will remain closed during lens changes. The result is a black screen. To determine the desired value, simply time the lens turret and add 1 second. The legal range is 0 to 9 seconds. 0 disables the function. Enter data with the number keys.

11. **Changeover Pulse (sec):** .2

This setting controls the duration or width of the pulse sent to the changeover. It is recommended that the Changeover Pulse be set to the minimum value that allows the changeover to complete its full stroke. The legal values are .1 to 1.0 seconds. Enter data with the number keys.

12. **Failsafe Delay (sec):** 2

This function is a film *bobble* delay designed to prevent premature shutdown

caused by platter or other types of rewind and film transport equipment during startup or any other portion of the presentation. Anytime the failsafe does not sense film presence during a presentation the Failsafe Delay timer is started, if film is detected before the timer expires, the presentation is not shutdown. If, however, film is not detected before the timer expires, the presentation is stopped and the alarm will sound. Legal entries range from 1 to 10 seconds. Enter data with the number keys.

13. **Cue Factor Default:** **.002**

This function is used in conjunction with CNA-200 *Cue Learn* system. The system learns the cue locations the first time a presentation is shown and places a “window”, based on the Cue Factor number. In the event of a missed cue, the CNA-200 maintains the proper timing of events by automatically inserting a cue at the end of the window.

Simply put, the cue window time is the *Cue Factor* multiplied by the *Cue Time*. For example, if The Cue Factor Default is .001 and the cue occurs 50 minutes into the presentation, the size of the window is: $.001 \times 50 = .05$ minutes or $(.05 \times 60)$ 3 seconds. Remember, the time of each window is based on the distance the cue is from the beginning of the film. So it follows that the further the cue is from the beginning of the film, the larger the window will be. Based on this, select a Cue Factor you can live with. For an average length movie, a Cue Factor Default setting of .002 is good.

Note: For more information see *Cue Window Factor* on page 66.

7. **Password #1:** **12**

This function sets the *low level* or projectionists’ password. Password #1 allows access to the Sync Loop number in Supervisory, Clock Start Times, Programs (format instruction only) and Cue Learn Times. It allows the projectionist to access the functions necessary to perform the job, while maintaining protection of the high level information. Legal entries are 00 through 99. Enter data with the number keys.

8. **Cue Learn:** **Manual**

This setting allows the Cue Learn Mode to be *manually* or *automatically* terminated at the end of the first presentation. In the Manual mode the operator is required to manually de-activate the Cue Learn Mode by pressing the Learn Mode key after the first presentation is completed. In the Auto mode the CNA-200 assumes that all cues were in their proper location and the presentation went as planned. At the end of the first presentation the

CNA-200 will automatically de-activate the Cue Learn Mode. The entries are **Auto** and **Manual**. Toggle the message with the Select Message key.

9. **Timed Start:** **Enabled**

This function controls access to the timed autostart function. The entries are **Enabled** and **Disabled**. When Timed Start is disabled the operator can not access the Time Start feature. Toggle the messages with the Select Message key.

10. **Clock Start:** **Enabled**

This function controls access to the clock autostart function. The entries are **Enabled** and **Disabled**. When Clock Start is disabled the operator can not access the Clock Start feature. Toggle the messages with the Select Message key.

11. **Check Cue Fault:** **Disabled**

When using the system Cue Learn mode feature there is a fault message that is displayed after running the presentation in *Learn* mode. The message “**CHECK CUE LEARN TIMES**” is displayed as a reminder to the operator to verify the cue times after the first show. This message can be suppressed by setting it to Disabled. Toggle the message with the Select Message key. See *Cue Learn Mode* on page 66.

12. **Missed Cue Fault:** **Disabled**

When using the system Cue Learn mode feature there is a fault message that is displayed after running the presentation in *Learned* mode. For example, the message “**MISSED CUE 3**” will be displayed if the system did not see cue foil 3 during the show. This message can be suppressed for those theatres that do not use cue foil on the film, or for some other reason do not want to see this fault message. Toggle the message with the Select Message key. See *Cue Learn Mode* on page 66 for more information.

13. **Fault Defeat:** **Disabled**

This function allows the operator to *bypass* the Film Presence, Film Motion, Film Tension and Xenon Fault inputs. This would normally be used only for testing purposes, not for normal operation. When Fault Defeat is set for Enabled, all the fault inputs are *bypassed*. When set for Enabled, the message “**FAULT DEFEAT ENABLED**” will be displayed as a reminder to the operator. The selections are Enabled and Disabled. Toggle the message with

the Select Message key.

14. **Run Hours: 12345 Elapsed**

This is a status only field, showing the number of hours the system has been running. It represents the accumulated time the projector has been operating. The elapsed time may be reset by entering **1 2 3 4 CLEAR**.

15. **Schedule A,B,C,D (hrs): 150 50 Elapsed**

These are four timed schedules which allow the setting of a timer (in hours) which will notify the operator each time the elapse time reaches the *set point*. For example, if Schedule A is set at 100 hours, the operator would be notified at 100 hour intervals. The message “**MAINTENANCE SCHEDULE A FAULT**” is displayed on all screens. The Elapsed timer must be reset to 0 in Supervisory by pressing **1 2 3 4 CLEAR** with the cursor on the Elapsed time field. This will clear the fault message. Setting the set point to 0 disables the Maintenance Schedule fault message.

These timers are most commonly used to drive periodic maintenance or keep track of specific equipment life such as the xenon bulb. The set point range is 1 to 65535 hours. Data entry is made with the number keys.

16. **Time of Day (24Hr): 14:30 3/21/1997 Fri**

This function is used to set the internal clock. Enter the time in a 24 hour format. Cursor right to edit the Month, Day, Year and Day of week.

17. **Time Format: 12Hr**

The clock can be set for either the 12 or 24 hour format. Toggle the message with the Select Message key.

18. **Output Configuration**

The last screen is used to configure the relay outputs. Most outputs can be configured for pulsed or maintained contacts, power-up state and fault-to state.

| Output | Contacts | Power-up | Fault-to |
|-------------------|-----------------|-----------------|-----------------|
| Lens: | Pulsed | No-op | No-op |
| Masking: | Pulsed | No-op | No-op |
| Sound: | Pulsed | Non-Sync | Non-Sync |
| H. Lights: | Pulsed | Up | Up |
| S. Lights: | Pulsed | Up | Up |

| | | | |
|--------------------|-------------------|--------------|--------------|
| Curtain: | Pulsed | No-op | No-op |
| Slide Proj: | <i>Maintained</i> | Off | Off |
| Out 1: | Pulsed | Off | Off |
| Out 2: | Pulsed | Off | Off |
| Out 3: | Pulsed | Off | Off |
| Out 4: | Pulsed | Off | Off |

The fields shown here in italics can not be edited. The contacts can be set for pulsed or maintained. The Power-up fields determine the power-up states of the outputs, and the Fault-to fields determine what the output will do on a fault condition. The legal values for lights are Up, Down, Mid 1 and Mid 2. The legal values the curtain are Open, Close, None and No-op. And the legal entries for the rest are On, Off and No-op.

Set-up Programs

The engineer/operator can program up to nine (9) individual programs. Each program may contain up to 99 lines or steps of instructions. In this section the procedures and rules for the program functions are covered.

The CNA-200 is a *cue-driven* automation. This means that events, such as lens, masking and sound changes, are initiated by a cue (normally foil placed on the film). These events are stored in the CNA-200's memory and are called *programs*. The CNA-200 gives you the ability to build and store up to nine different programs. Each program can contain up to ninety-nine *instructions* which are performed sequentially. An instruction is a particular function that will be executed during a *program step*. It may have a timed relationship to the step; that is, stage lights may be programmed to dim ten seconds after the instruction is encountered in the program. Each instruction is identified by an *instruction number*. Figure 3.10 shows the relationship of the cues and the segments of a program in which events are initiated by the automation. Figure 3.10 also shows a typical program segment and the components that make it up.

- House and Stage Lighting
- Curtains
- Slide Projector
- Cue Factor
- Film Sound and Lens Formats
- Number of Cues
- Time Delays
- Projector Control
- Intermissions

House Lights

| | | |
|---|--------------------|----------------------------------|
| 1 | House Lights Up | 00:00 to 59:59 (minutes:seconds) |
| 2 | House Lights Down | 00:00 to 59:59 (minutes:seconds) |
| 3 | House Lights Mid 1 | 00:00 to 59:59 (minutes:seconds) |
| 4 | House Lights Mid 2 | 00:00 to 59:59 (minutes:seconds) |
| 5 | House Lights None | 00:00 to 59:59 (minutes:seconds) |

Each of these instructions operate in the same manner to control the four House Light outputs. House Lights None would normally only be used when contacts are configured for *Maintained*. A single timer is used to implement these five instructions. Execution of the instruction simply sets and starts the timer. When the timer times out (counts down to zero) the output is set to the desired state. When the outputs are configured for *Pulsed*, a transition to the *on* state will cause the output to occur. Control immediately interprets the next instruction in the list. The time is specified in minutes and seconds.

Note: Executing one of these instructions again (before the timer times out) simply overrides the previous instruction.

Stage Lights

| | | |
|---|-------------------|----------------------------------|
| 6 | Stage Lights Up | 00:00 to 59:59 (minutes:seconds) |
| 7 | Stage Lights Down | 00:00 to 59:59 (minutes:seconds) |
| 8 | Stage Lights None | 00:00 to 59:59 (minutes:seconds) |

This set of instructions each operate in the same manner to control the two Stage light outputs. A single timer is used to implement these three instructions. Execution of the instruction simply sets and starts the timer. When the timer times out (counts down to zero) the output is set to the desired state. When the outputs are configured for *Pulsed*, a transition to the *on* state will cause the pulse to occur. Control immediately interprets the next instruction in the list. The time is specified in minutes and seconds.

Executing one of these instruction again (before the timer times out) simply

overrides the previous instruction.

Curtain

| | | |
|----|---------------------|----------------------------------|
| 9 | Curtain Open | 00:00 to 59:59 (minutes:seconds) |
| 10 | Curtain Close | 00:00 to 59:59 (minutes:seconds) |
| 11 | Curtain None | 00:00 to 59:59 (minutes:seconds) |
| 12 | Curtain Call | 00:00 to 59:59 (minutes:seconds) |
| 13 | Curtain Close Early | 00:00 to 59:59 (minutes:seconds) |

Curtain Open, Curtain Close and Curtain None each operate to control the curtain open and close outputs. A single timer is used to implement these instructions. Execution of the instruction simply sets and starts the timer. Later, when the timer times out the output are set to the desired states. Control immediately interprets the next instruction on the list. The time is specified in minutes and seconds.

Executing one of these instructions again (before the timer times out) simply overrides the previous instruction.

Curtain Call is a special instruction that is active only when running in the *Learned Mode*. Based on the learned time of the next film cue, the instruction calculates the time before that cue and executes a curtain close output. Upon reading that cue the curtain will reopen. For example, with the Curtain Call is set for a time of 10 seconds the curtain will start to close 10 seconds before the next cue is read. When the cue is read the curtains will begin to open. This instruction can be used to close the curtain at the end of a trailer and then reopen the curtain at the beginning of the main feature. Time is specified in minutes and seconds and should be set 2 to 5 seconds longer than the time required for the curtain to fully close. Control immediately interprets the next instruction on the list.

Curtain Close Early is another special instruction that is only active in the *Learned Mode*. The curtain will close prior to the last cue. The amount of time set determines how *early* the curtain closes. This could be used to synchronize the curtain closing with the changeover to prevent the audience from seeing a “white” screen at the end of the presentation.

Slide Projector

| | | |
|----|---------------------|----------------------------------|
| 14 | Slide Projector On | 00:00 to 59:59 (minutes:seconds) |
| 15 | Slide Projector Off | 00:00 to 59:59 (minutes:seconds) |

This set of instructions operate to control the Slide Projector output. A single timer controls these instructions. Executing one of these instructions sets and

starts the timer. Executing one of these instructions again (before the timer times out) overrides the previous instruction. Time is specified in minutes and seconds. Data entry is made with the number keys

Cue Factor

16 Cue Factor .000 to .999

This instruction overrides the Cue Factor Default (Supervisory function) for the remainder of the program and adjusts the cue window accordingly. Control immediately interprets the next instruction on the list. Data entry is made with the number keys.

Film Format

17 Format 1: Sound Lens

This instruction allows the film format parameters to be selected. The changeover occurs as defined in supervisory function. System immediately interprets next instruction on the list. Sound selections include: Non-Sync; Mono; SVA; SR; Dig 1; Aux 1; Dig 2; Aux 2. Aux 1 and 2 can be used for any desired function i.e. a mute, synthesized stereo, magnetic, special types of noise reduction. Lens selections include: Flat; Scope; Special. The legal range for the format number comment is 0 to 20.

Wait Cue

18 --- Wait Cue --- 0 to 20

This instruction causes the program to wait for one of the following:

In the *Learn Mode* (Cue Learn active):

1. A film cue
2. Cue input (key)
3. Failsafe (end of film) when last cue is expected by program

In the *Learned Mode* (Cue Learn not active):

1. A film cue within learned cue window
2. Cue input (key)
3. Failsafe (end of film) within last cue window

The failsafe can be used as the last cue if a failsafe shutdown is desired.

Control immediately executes next instruction on the list. Data entry is made with the number keys.

Shutdown Delay

19 Shutdown Delay 00:00 to 59:59 (minutes:seconds)

This instruction extends the normal shut down time of the projector motor in the time specified. Shutdown Delay overrides the *global* end of show timer. This can be used to allow film to clear the projector before shut down. Time is specified in minutes and seconds.

Wait

20 --- Wait --- 00:00 to 99:99 (minutes:seconds)

This instruction causes a delay for the specified time in minutes and seconds. When the Wait instruction is encountered in a program the timer starts to “tick”. No other instructions in the program are executed until the timer times out (counts down to zero). This instruction, for example, can be used with the Curtain instructions to perform a “curtain call” or for special intermission features.

A manual cue input or a film cue will abort this instruction and control will immediately execute the next instruction on the list. If used during an intermission, a start input will abort the Wait instruction.

When the time is set to the maximum value of 99:99 the instruction waits indefinitely. A RESUME or remote RESUME will terminate the wait and continue the program.

Changeover

| | | |
|----|------------------|----------------------------------|
| 21 | Changeover Open | 00:00 to 59:59 (minutes:seconds) |
| 22 | Changeover Close | 00:00 to 59:59 (minutes:seconds) |
| 23 | Changeover None | 00:00 to 59:59 (minutes:seconds) |
| 24 | Changeover Auto | 00:00 to 59:59 (minutes:seconds) |

The *Sound Changeover* is normally handled automatically by the control. This set of instructions is very powerful and provides the user with more control of the Sound Changeover outputs. Time is specified in minutes and seconds.

Using the Changeover Open, Changeover Close and Changeover None instructions in a program simply override the *automatic* Sound Changeover *logic*, with the exception of a film break.

Use the Changeover None to suppress the automatic open or close of the changeover. Use the Changeover Open and Changeover Close to control the Changeover outputs as desired.

Use the Changeover Auto to return control of the Sound Changeover back to the *automatic* changeover open and close *logic*.

The **delay time** can be used to delay the execution of the instruction by the amount specified. For example if you want the changeover to close, and then re-open after 8 seconds, you would use the instructions as follows:

| | | |
|-------------|-------------------------|-------------|
| 1-10 | Changeover Close | 0:00 |
| 1-11 | Changeover Open | 0:08 |

Enter time with number keys.

Projector Motor/Lamp

25 Projector Motor/Lamp On
26 Projector Motor/Lamp Off

The Projector Motor/Lamp On instruction turns *on* the projector motor and xenon lamp but does not initiate automatic show start logic (changeover open, etc.). A "Wait Cue" instruction (and a film cue) is required to initiate show start logic.

The Projector Motor/Lamp Off instruction causes the projector motor and xenon lamp to turn *off* using the normal show end timers and closes the changeover. This instruction can also be used to keep the projector motor from coming on at the beginning of a show.

Intermission Wait

27 Intermission Wait 00:00 to 99:59 (minutes:seconds)

This instruction is used for intermissions and other special applications. This instruction automatically switches the system to non-sync sound and initializes the projector motor shutdown. The changeover is closed with the normal delay. Shutdown is maintained until the programmed time is expired or a RESUME is received. This instruction requires a Wait Cue instruction (and a film cue) to initiate the *show start logic*.

When the time is set to the maximum value of 99:99 the instruction waits indefinitely. A RESUME or remote RESUME will terminate the wait and continue the program.

A cue key or remote cue from the cue detector will terminate the wait and execute the next Wait Cue instruction.

The following table summarizes the 27 Program Instructions available with version 1.003.

| No. | Instructions | Range |
|-----|--------------------------|---|
| 1 | House Lights Up | 0:00 to 59:59 minutes:seconds |
| 2 | House Lights Down | 0:00 to 59:59 minutes:seconds |
| 3 | House Lights Mid 1 | 0:00 to 59:59 minutes:seconds |
| 4 | House Lights Mid 2 | 0:00 to 59:59 minutes:seconds |
| 5 | House Lights None | 0:00 to 59:59 minutes:seconds |
| 6 | Stage Lights Up | 0:00 to 59:59 minutes:seconds |
| 7 | Stage Lights Down | 0:00 to 59:59 minutes:seconds |
| 8 | Stage Lights None | 0:00 to 59:59 minutes:seconds |
| 9 | Curtain open | 0:00 to 59:59 minutes:seconds |
| 10 | Curtain Close | 0:00 to 59:59 minutes:seconds |
| 11 | Curtain None | 0:00 to 59:59 minutes:seconds |
| 12 | Curtain Call | 0:00 to 59:59 minutes:seconds |
| 13 | Curtain Close Early | 0:00 to 59:59 minutes:seconds |
| 14 | Slide Projector On | 0:00 to 59:59 minutes:seconds |
| 15 | Slide Projector Off | 0:00 to 59:59 minutes:seconds |
| 16 | Cue Factor | .000 to .999 |
| 17 | Format : Sound Lens | Non-Sync;Mono;SVA;SR; Dig 1;Aux 1;Dig 2;Aux2 Flat;Scope;Special |
| 18 | Wait Cue | 0 to 20 |
| 19 | Shutdown Delay | 0:00 to 59:59 minutes:seconds |
| 20 | Wait | 0:00 to 99:99 minutes:seconds |
| 21 | Changeover Open | 0:00 to 59:59 minutes:seconds |
| 22 | Changeover Close | 0:00 to 59:59 minutes:seconds |
| 23 | Changeover None | 0:00 to 59:59 minutes:seconds |
| 24 | Changeover Auto | 0:00 to 59:59 minutes:seconds |
| 25 | Projector Motor/Lamp On | N/A |
| 26 | Projector Motor/Lamp Off | N/A |
| 27 | Intermission Wait | 0:00 to 99:99 minutes:seconds |

Basic program operation

The CNA-200 is a *cue-driven* automation. This means that events, such as lens, masking and sound changes, are initiated by a cue (normally foil placed on the film). These events are stored in the CNA-200's memory and are called **programs**. The CNA-200 gives you the ability to build and store up to nine different programs. Each program can contain up to ninety-nine **instructions** which are performed sequentially. An **instruction** is a particular function that will be executed during a *program step*. It may have a timed relationship to the step; that is, stage lights may be programmed to dim ten seconds after the instruction is encountered in the program. Each function is identified by an *instruction number*.

A **Program** is a series of events that the system will perform in the order in which those instructions are encountered in a Program list. Most instructions have timers that determine when the actual event will take place in relation to when the instructions is encountered. For example, when the "House Lights Down 0:30" instruction is encountered; the system understands this instruction, and proceeds to the next instruction on the list. 30 seconds later the house lights will go down.

Important Program Instructions are: Format, Wait Cue, and Wait.

Format: Format configuration will be displayed when the system is running a film presentation, show the type of sound, lens, and projector speed used. Up to 10 different Format instructions can be used during a program.

Wait Cue: The run input can be thought of as a first cue that starts the program. All instructions are executed until the first WAIT CUE is encountered. The cue may be from the cue detector assembly or from the Cue Input key. The system will then perform the next set of instructions on the list up to the next WAIT CUE instruction. When the last WAIT CUE instruction in the program list is encountered, the system will perform the End of Show functions (changeover close, sound to non-sync, etc.). A maximum of twenty cues may be encountered in a Program.

Wait: Halts the execution of any program instructions for a prescribed period of time in minutes and seconds. WAIT may be used in a Program during a film portion of the program, as well as after the film to initiate programmed intermission functions. After the programmed time has expired, the system performs the next instruction on the list. WAIT may be terminated at any time by pressing the Start or Cue Input.

Building Programs

Press the [Menu] key to get to main menu.

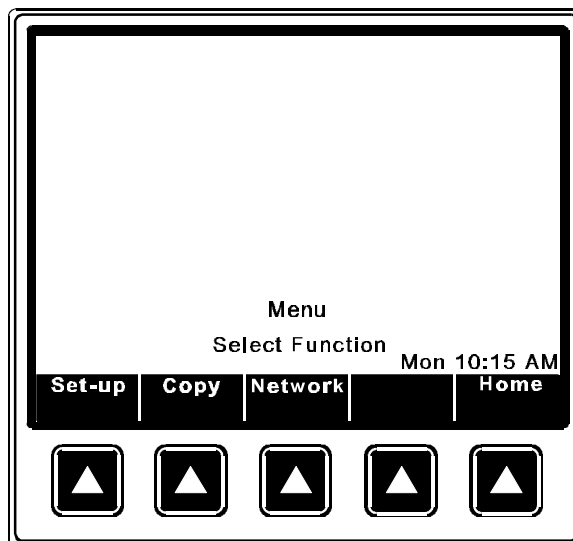

Figure 3.11

Press the [Set-up] key to get to the set-up menu.

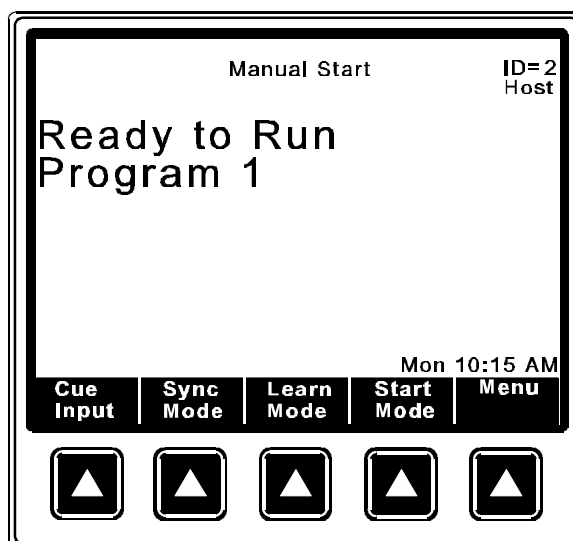

Figure 3.12

Press the [Set-up Program] key and enter the *high level* password.

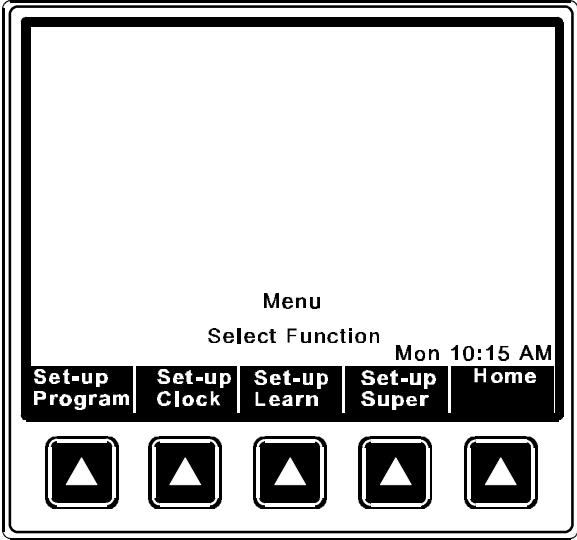

Figure 3.13

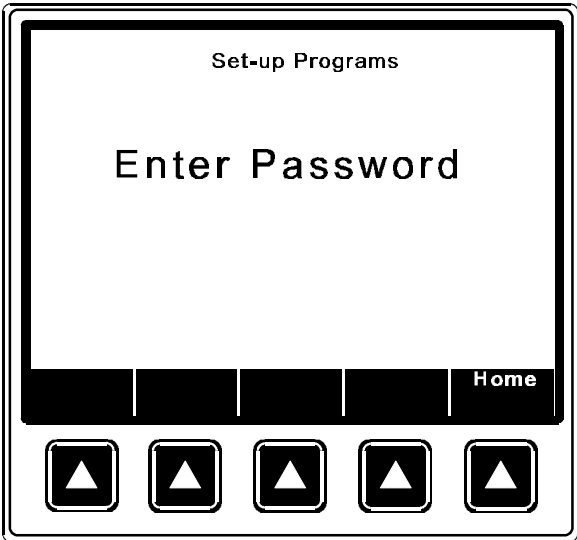

Figure 3.14

The screen displays an empty program with the cursor on step 1. (The first number is the program number, the second is the step number.) Begin by pressing the [Insert] key. The cursor will highlight the entire step. Once in **Insert mode** there are two methods of entering instructions. The first method is to use the cursor up and down keys to scroll through the list of 27 instructions. The second method is to enter the number of the instruction. The correct instruction will be inserted and displayed.

Press [Insert]:

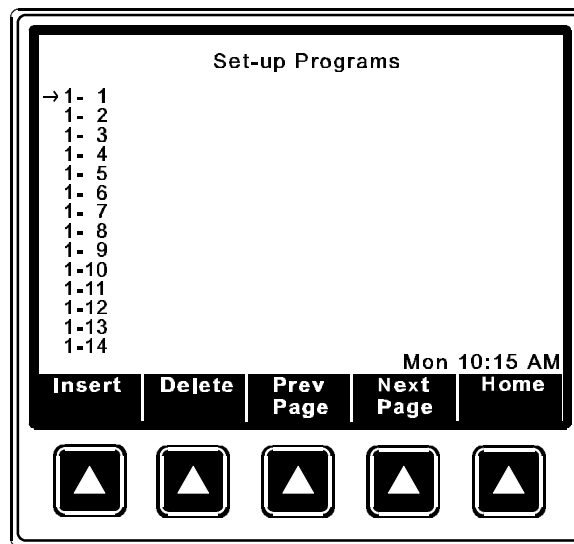

Figure 3.15

The cursor will highlight step 1- 1:

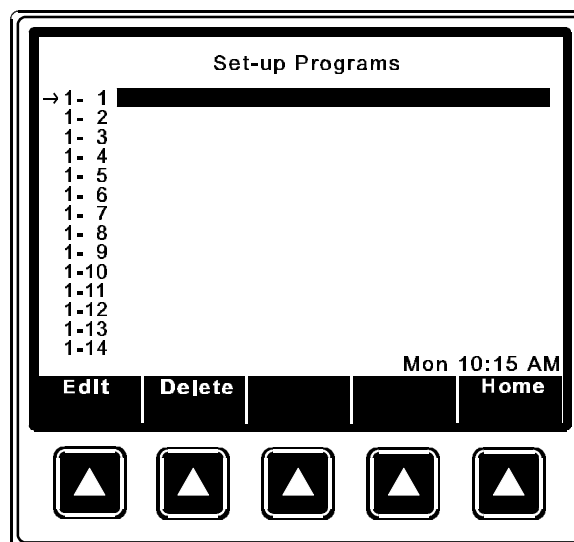

Figure 3.16

Press the cursor down key to scroll the list of instructions 1 through 27.

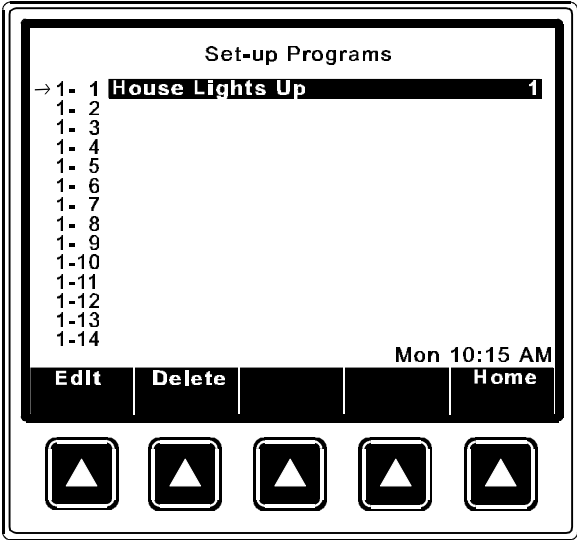

Figure 3.17

Press [1][7] enter the Format instruction.

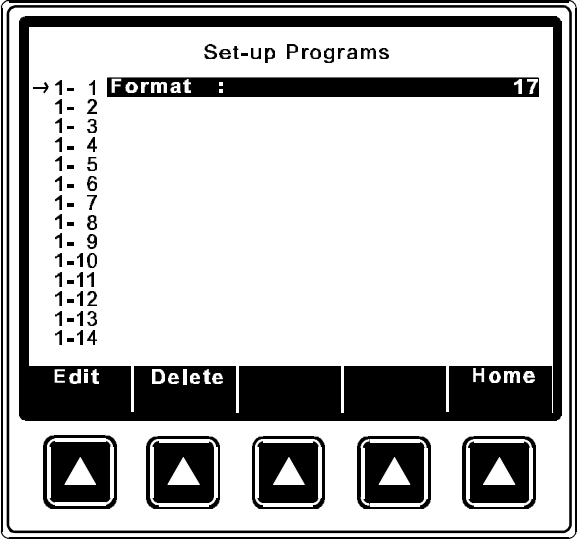

Figure 3.18

Insert Mode allows you to edit the fields in each instruction. The Format instruction has three fields to edit. Use the cursor right and left keys to scroll through the fields. Use the number keys to edit the numeric data and the Select Message key to edit text fields.

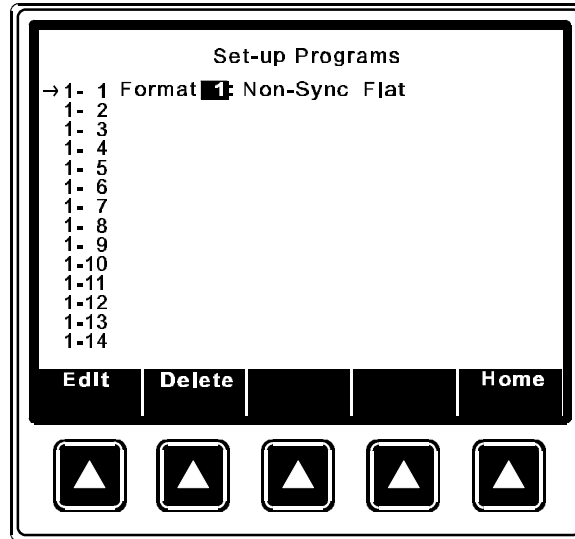

Figure 3.19

Note: When inserting instructions by entering the instruction number, enter a leading 0 for the single digit instruction numbers. Or press [ENTER] after entering the single digit number.

Cursor right to the next field.

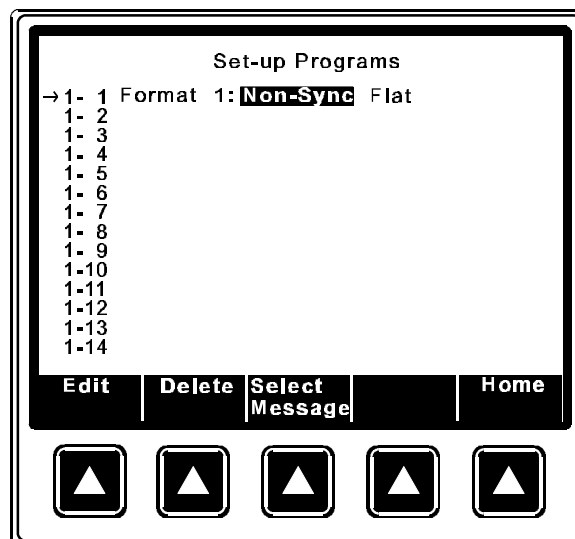

Figure 3.20

Press [Select Message] to change the sound formats.

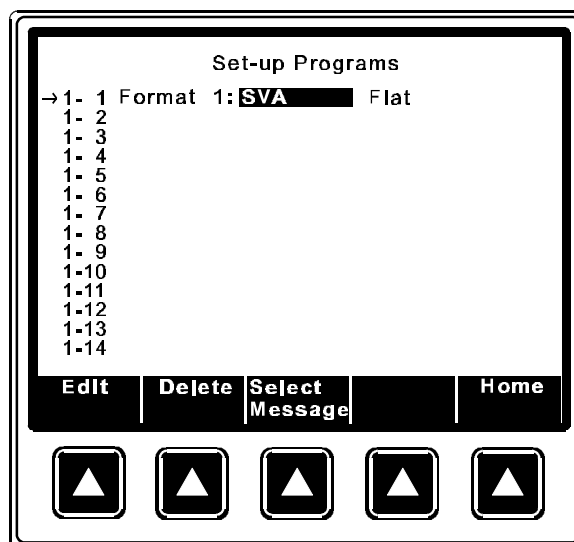

Figure 3.21

Cursor right to the lens format field. Press [Select Message] to edit.

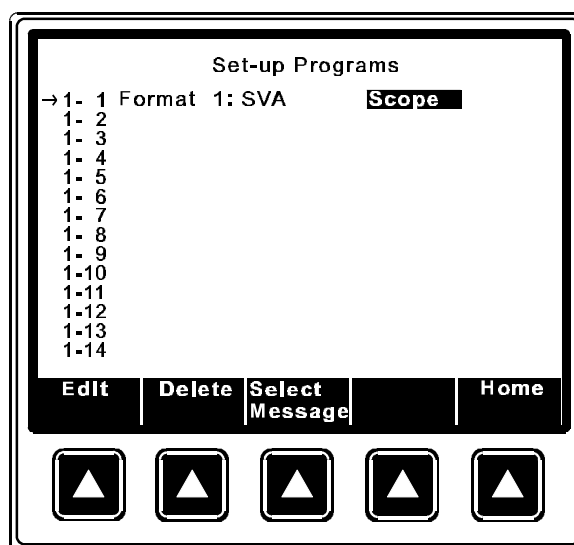

Figure 3.22

Cursor down to the next field and select instruction 3.

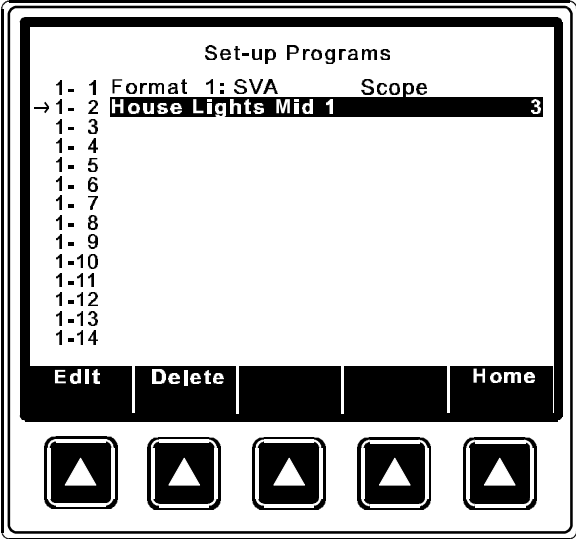

Figure 3.23

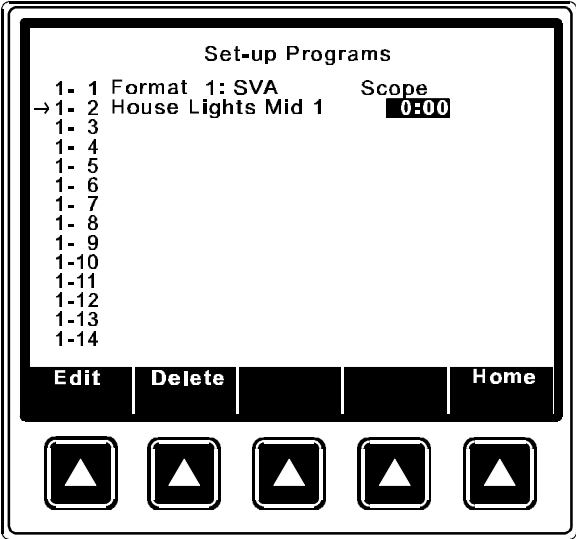

Figure 3.24

Enter a delay time.

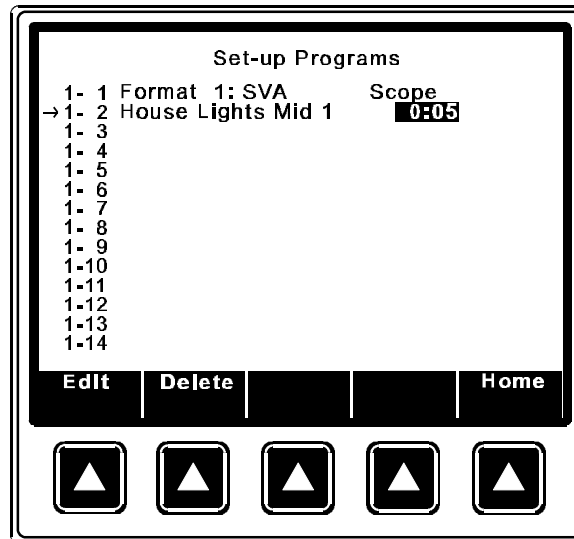

Figure 3.25

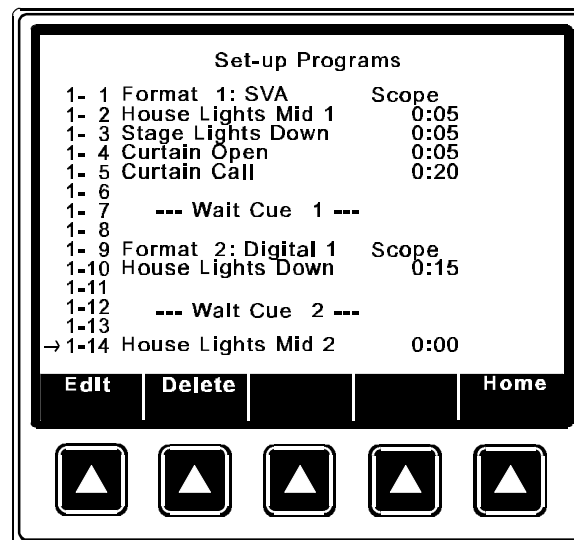

Figure 3.26

Programming notes

Remember "anticipatory" instructions (Curtain Call and Curtain Close Early) must be encountered before the Wait Cue instruction and are only active in the "Learned" mode.

Use the Cue Learn Mode on the first showing of a feature. If film cues are absent, insert cues manually as required using Cue Input key.

To delete an entire program: copy an "empty" program into the program you want to delete; or enter step #1 of the program and repeatedly press Delete to clear all program steps. Be sure all steps are cleared.

The CNA-200 contains a "Canned" program called "Default 1" in the Local Copy screen. Copy this program to one of the program locations. This program can be useful as a starting point and can be modified to suite your particular requirements.

The last Wait Cue instruction will initiate the show close functions.

When data entry is complete verify the information by scrolling through the program and checking it against the written copy. Verify the actual operation of the program by running a "dummy" show. remember to experiment with fault and power loss conditions.

Set-up Cue Learn

Each time a program is executed the computer stores each cue time in memory. If the CNA-200 was in *cue learn mode* when the show ended the values for the cue times are saved to a table in *battery-backed* memory. The values in this table can be viewed and edited. A program can store up to twenty cue times. Access is granted with *password 1* or *2*. To access the cue times from the Set-up menu, press [Set-up Learn] and enter the password.

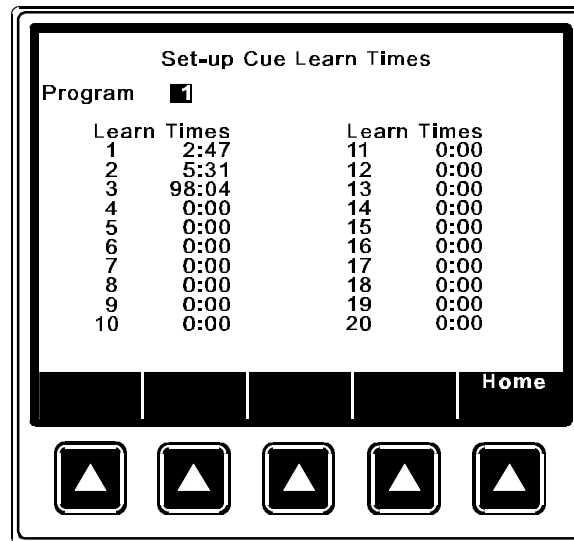

Figure 3.27

Enter the program number you want to view and press [ENTER]. Now you are viewing the *cue learn times* for Program 1. At this time you may enter or edit the cue learn times by using the number keys. Press the cursor keys or [ENTER] to move to different learn time fields. The learn times are displayed in minutes and seconds. The maximum value that can be entered is 999 minutes 59 seconds (equivalent to 16 hours 39 minutes and 59 seconds). Press the [CLEAR] key to reset the cue time to 0:00. Clear all cue times which are not being used. **Verify upon completion that all cue times are arranged in chronological ascending order.**

Set-up Clock Start Times

The Clock autostart function allows automatic programmed start times on a daily basis. Each day's schedule can be different if required and can consist of any combination of available Programs. Up to ten Programs can be scheduled per day. The Clock function must be enabled in the Supervisory (only with the *high level*, password #2). Schedules can be set with passwords #1 and #2; and the Clock Start Mode can be activated by pressing the [Start Mode] key while in the *Run Mode* screen.

From the Set-up screen press [Set-up Clock].

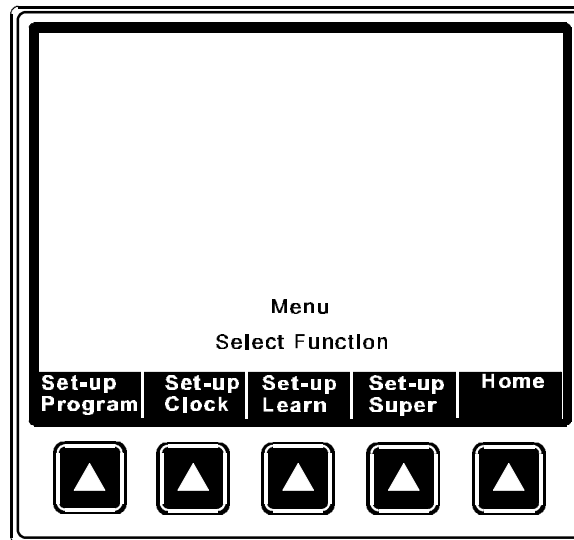
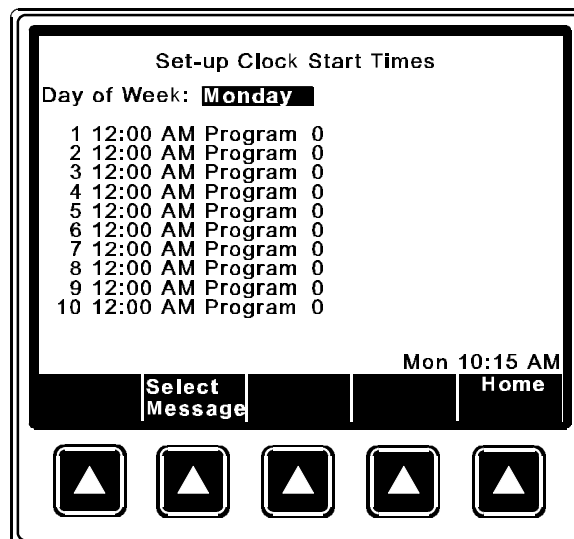

Figure 3.28

Enter the password and press [Select Message] to select a day of the week.



Cursor down or press [ENTER] to edit the first start time.

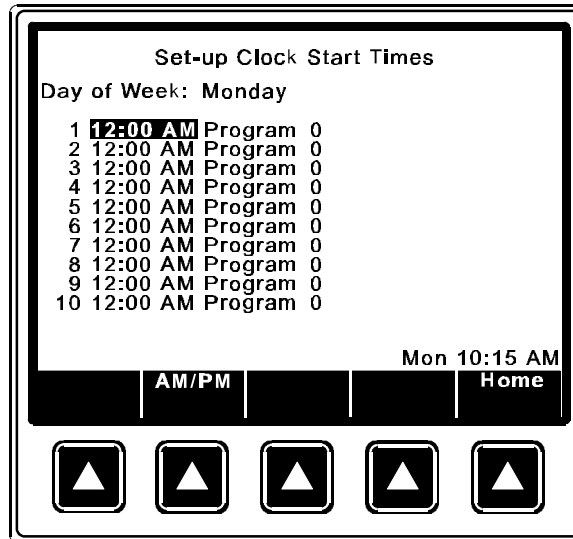

Figure 3.30

Edit the time with the number keys.

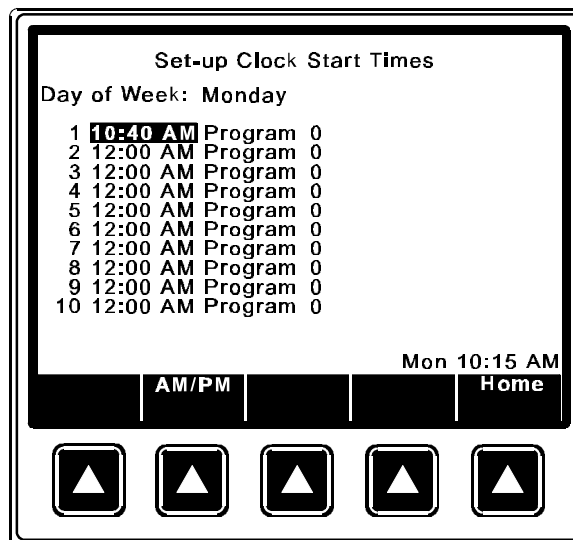

Figure 3.31

In 12 hour mode, toggle AM and PM with the AM/PM key.

Cursor to the program number field and edit the program number with the number keys. Continue to enter start times for the day in chronological order.

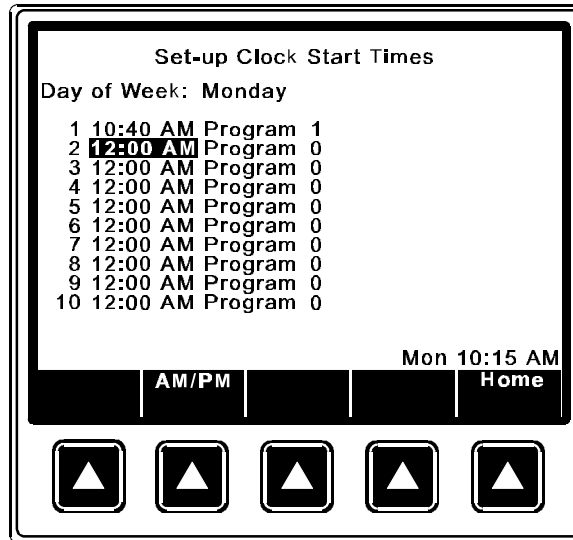

Figure 3.32

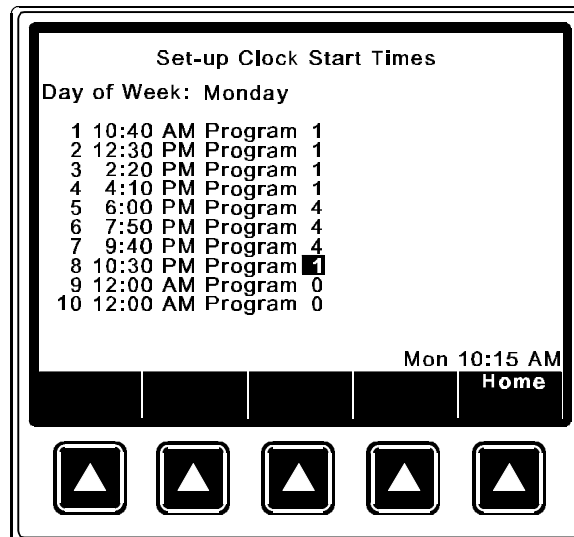

Figure 3.33

If fewer than 10 clock start times are required for the day, enter the number 0 in the program number field. These entries will be ignored. Scroll back to the Day of Week field and select a new day to edit.

HINT: Use the copy function to copy program clock start times from one day to another and edit as required. (See *Local Copy* section.)

The Copy Function

The Copy function can be used to copy Clock Start Times, Programs or Supervisory data from one location to another. The copy function provides the option for a *Local* copy or a *Network* copy. The Local Copy is used to copy Clock Start Times or Program from one location to another. For instance, if clock start times are the same for Monday as for the rest of the week, the times can be entered for Monday and then copied to other days with the same schedule. Similar schedules can be copied and then edited. The same holds true for building Programs. For instance, make Program #4 a copy of Program #2 and edit as required. Using the Local Copy function dramatically reduces the amount of data entry normally required in building programs.

The Network Copy is used to copy Clock Start Times, Programs or Supervisory data from a *remote* CNA-200. This further reduces the amount of data entry, particularly in large multiplexes. Using Network Copy you can only copy program data *from* a remote CNA-200 to the CNA-200 that is performing the copy. You are prohibited from copying *to* a remote CNA-200.

To access the copy screens press [Copy] from the Main Menu screen.

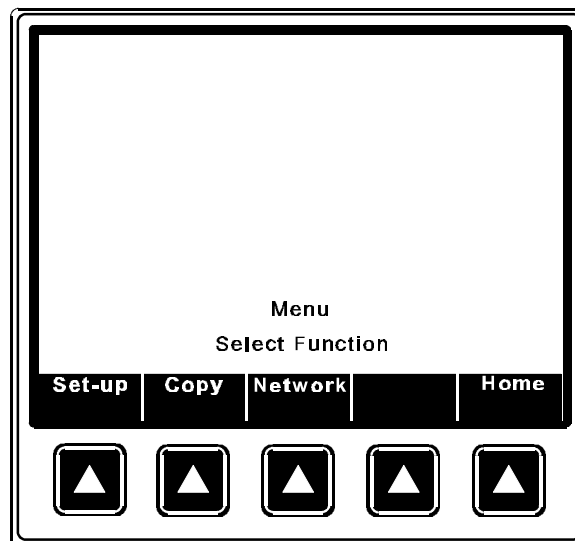

Figure 3.34

From the Copy Menu you may select the Local or Network Copy functions.

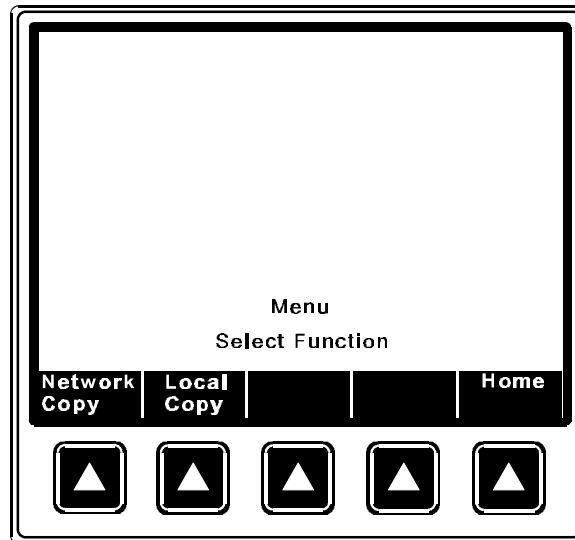
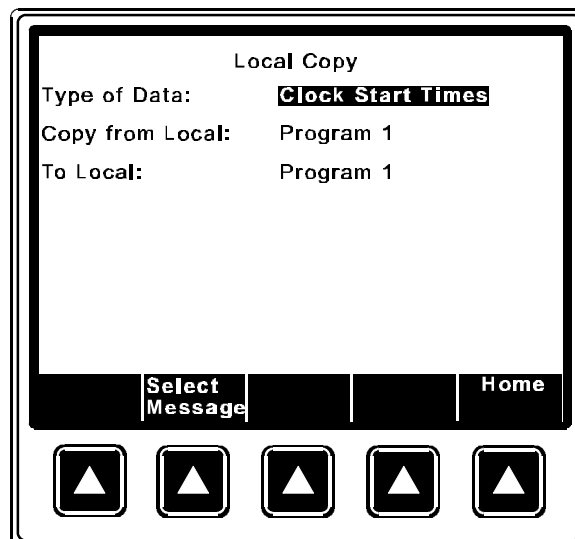

Figure 3.35

Local Copy

This function allows the operator to copy a full days start times to another day. Any day can be copied to any other day. If a full days start times have been set up for Monday, for example, and the same schedule is valid for the other days, the start times can be copied from Monday to Tuesday, from Monday to Wednesday, from Monday to Thursday, and so on.

This screen also allows the operator to copy an entire program from one location to another and then edit the program as necessary. Press [Local Copy] and enter the high level password.



Enter the "Type of Data" to copy by pressing the [Select Message] key.

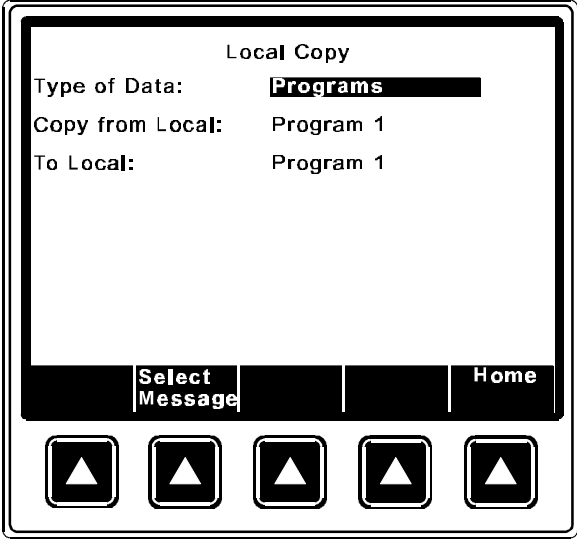

Figure 3.37

Cursor to the "Copy from Local" field and select the program you want to copy data from.

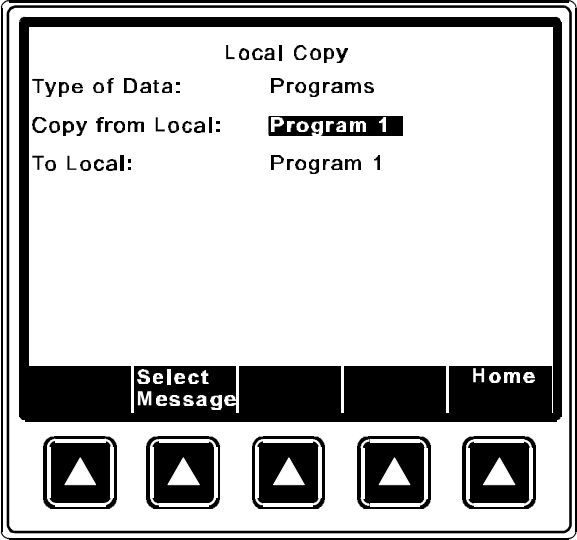

Figure 3.38

Cursor to the “To Local” field and select the program number you want to copy data to.



Figure 3.39

Press [ENTER]. You are prompted with an “Are You Sure (Yes/No)?” message.

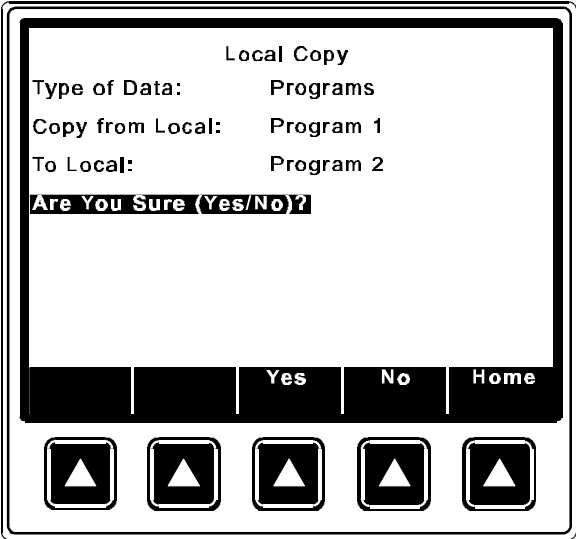

Figure 3.40

Press [Yes] to perform the copy.

The “Copy Complete” message indicates the copy was successful.

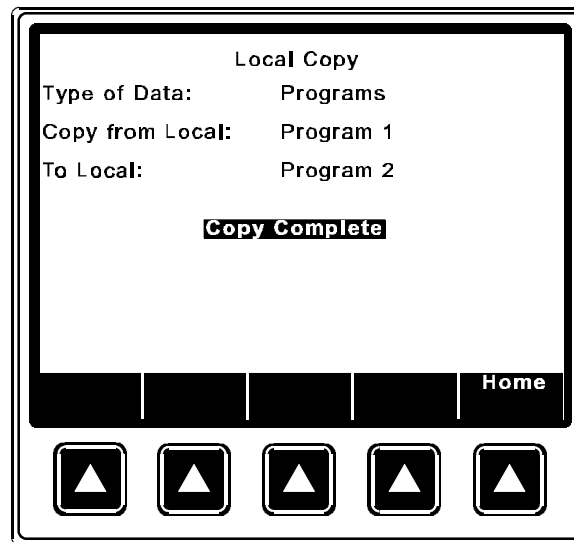

Figure 3.41

The same procedure is followed when copying Clock Start Times. The Local Copy screen also contains a “Canned” program called **Default 1**. You can copy this program to one or more of the program locations. This program can be useful as a starting point and can be modified to suite your particular requirements.

Note: You can not copy *to* a program that is running. The message “Can’t Copy to Show in Progress” will be displayed to indicate this.

Network Copy

The Network Copy function allows the operator to copy Programs, Cue Learn Times, Clock Start Times and Supervisory data from a remote CNA-200.

This function allows the operator to copy Clock Start Times for the whole week from a remote CNA-200. For example, when a movie is moved from one house to another and the start times are to remain the same for the movie, the operator can quickly copy the start times.

When copying from a remote CNA-200 you need to know the ID number of the remote CNA-200 you want to copy from. The ID number of a CNA-200 is normally the same number of the movie house it is in. The start times can be copied using either password #1 or #2.

The Program copy option allows the programmer to copy a program from any

remote CNA-200 on the network to any one of the nine (9) program locations at the local CNA-200. It also provides the option to copy *all* the programs at one time from a remote. The *cue learn times* for each program are also copied. Password #2 is required to copy programs over the network.

This feature is useful when movies are moved from one house to another. For example, the movie in house #4 needs to be quickly moved to house #8 and Program#1 in house #4 is needed to run the movie. It is determined by the operator that the program will be copied to the Program #4 location at the CNA-200 in house #8. The operator would perform the copy from house #8.

Select Supervisory Data to copy the Supervisory data from a remote CNA-200. All Supervisory data except for Sync Loop number, Run Hours and Maintenance Schedules are copied by this function. Progress status messages will be displayed as necessary.

Enter the Network Copy screen and select the “Type of Data” to be copied.

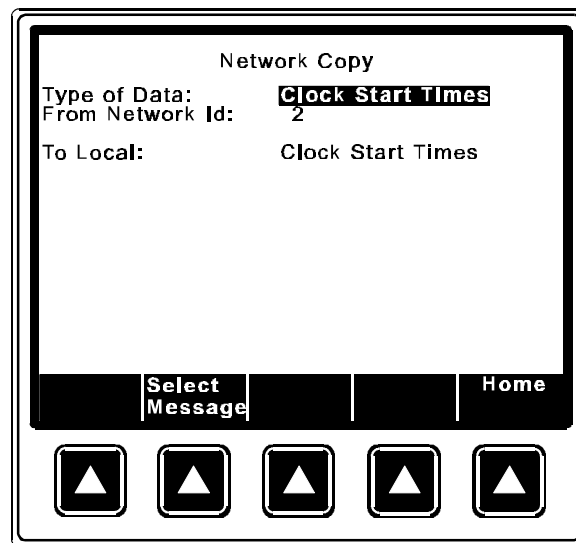
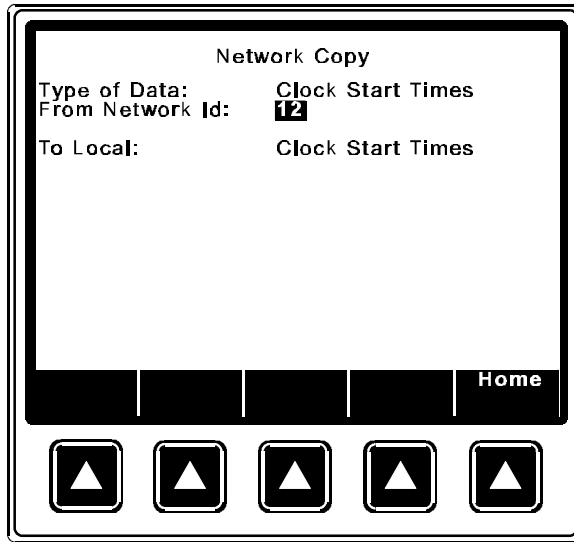

Figure 3.42

Cursor to the “From Network ID” field and enter the ID (usually the house number) of the CNA-200 you want to copy data from.



Press enter and you are prompted with the “Are You Sure (Yes/No)?” Message. Press [Yes] to complete the copy.

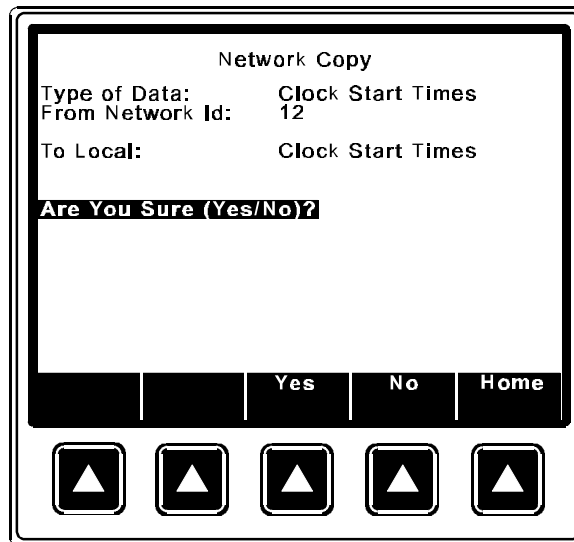

Figure 3.44

The screen will display the message “Network Transfer Complete” to indicate a successful copy.

Network Status Screens

There are three Network “Status” screens used to display the status of devices connected to the Local I/O Network (LIN) and the Local Synchronous Network (LSN). The three screens are the LSN Status, LIN Status and Remote Monitor. These screens are a valuable tool for the installation engineer and projectionist.

LSN Status

The “Local Sync Network Status” screen is an *overview* of ID and LOOP numbers of all devices on the network. This includes CNA-200s, CNA-100s, RSM-10 Remote Monitors and the PC Host. Up to 64 devices can be displayed on this screen. Press the [Network] key from the Main Menu.

Press [LSN Status]

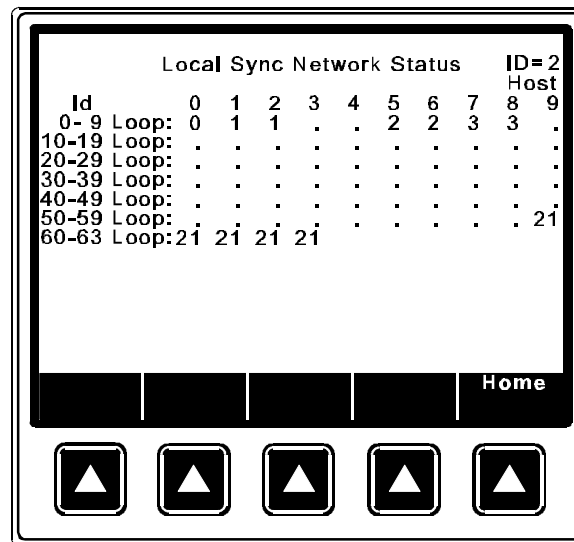

Figure 3.45

Each of the 64 positions on the screen represent a network ID number 0 through 63. Each ID will display either a sync LOOP number of or a “.”. The “.” indicates that there is no device at that ID.

LIN Status

The “Local I/O Network Status” screen is an overview of the devices connected to the “I/O” network (i.e. Booth and Console termination panels). Press [LIN Status] to view this screen.

| Local I/O Network Status | | | | | | | |
|--------------------------|---------|-----|-----|-----|-----|------|-------|
| Id | Device | Ver | Chk | Pup | Err | ErrT | Fault |
| 1 | Console | 1 | 221 | 1 | 0 | 0 | |
| 3 | Booth | 1 | 221 | 1 | 0 | 0 | |

Figure 3.46

| | |
|---------------|---|
| Id | Indicates the ID number of the device. |
| Device | Is the name of the device. |
| Ver | Is the software version number. |
| Chk | Is the checksum number. |
| Pup | Counts the number of times the device was powered up or reset. |
| Err | Counts the number of times the CNA-200 has polled the remote device with no response. |
| ErrT | Tracks the number of times the CNA-200 has polled the remote device. |
| Fault | Fault messages to indicate the type of problem that exists. The messages are: |

DevErr
CommErr
TimeOut

“DevErr” indicates that the CNA-200 does not recognize the remote device. This could be due to software version incompatibility. “CommErr” indicates that the remote device is not responding regularly enough. This could be due to a defective remote device or the wiring to it. “TimeOut” indicates a communication timeout condition, meaning that the remote device stopped responding after 5 seconds.

Any of these faults will cause a “LOCAL I/O NETWORK FAULT” message to be displayed on the top line of the display. Correct the problem and press the ALARM CANCEL key to clear message.

Remote Monitor

This screen displays the status of all CNA-200s and CNA-100s on the network.

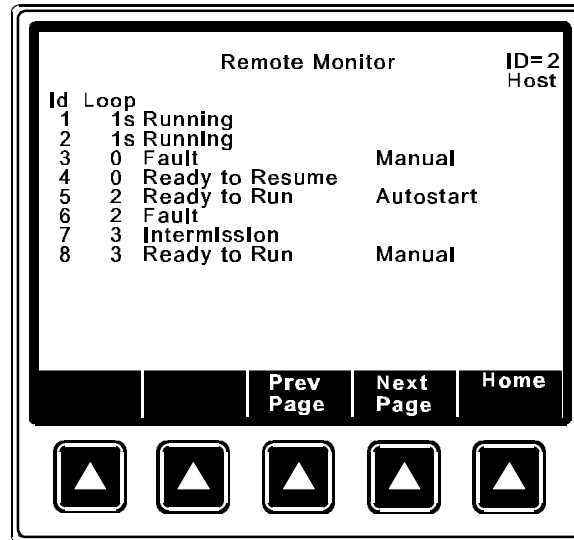

The CNA-200s will be displayed in order of ID number. The next column displays the Loop number. An “s” is displayed to indicate running synchronous or interlock. The following messages will be displayed to indicate the various conditions:

Ready to Run
 Ready to Resume
 Running
 Intermission
 Fault
 Fault - Alarm
 Manual
 Autostart

The “Fault - Alarm” message is displayed to indicate an alarm condition. If the alarm is from a remote CNA-200 the local screen will display:

REMOTE ALARM AT ID: dd

where dd is the ID number of the CNA-200 where the fault occurred. The alarm at all remote CNA-200 automations will sound 10 short beeps.

Section 4

OPERATION

Cue Learn Function

The "Wait Cue" instruction waits for a cue input before executing subsequent instructions in the program. Cues can be input manually using the Cue Input key, or foil cues on the film can be sensed by the cue detector of the failsafe assembly.

The Cue Learn function should be used on the first run of the program and after any change is made to the film itself (adding, deleting or moving cues). Using the internal clock, the CNA-200 will "learn" when the cues of a particular film should occur. After learning cue times all subsequent presentations will be run in the "Learned" mode. The CNA-200 will expect to encounter these cues at particular times. If film cues are not encountered within a specified "window", the system will automatically "insert" a cue allowing the program to carry out the next set of instructions. If any of the film cues are missed during a presentation an error message will be displayed at the end the show indicating which cues were missed. The size of the "window" is defined by the Cue Factor Default function in the Supervisory. The Cue Factor Default can be overridden by using the Cue Factor instruction in the Program allowing you to vary the width of the "window" throughout the Program. Note that the Cue Input key on the control panel is always active.

The Cue Learn function in the Supervisory can be set to Auto or Manual. In the Auto mode Cue learn is automatically disabled after the first run of the program, after which all subsequent runs will be in the "Learned" mode. In the Manual mode Cue Learn must be disabled manually by pressing the Cue Learn key.

Cue Window Factor

The Cue Window Factor is a function of the cue times measured. Briefly, in Cue Learn Mode, the system measures the cue times produced using the film cue foils. Thereafter, if cues are missing, the system automatically supplies them. The width of the window is calculated using the Cue Window Factor and is *centered* around the normal cue time. Using this system, the projectionist does not have to be concerned about any missing or errant cues, once cues have been learned.

The cue window is calculated to be sufficiently wide to accommodate any timing variations due to changes in motor speed caused by power line voltage or frequency fluctuations.

The Cue Window is calculated by the following equation:

$$\text{Cue Window} = (\text{CWF value}) \times (\text{cue location})$$

EXAMPLE: CWF value = 0.002, cue location = 2 hours

$$\text{Cue Window} = 0.002 \times 2 \text{ hours or } 120 \text{ minutes or } 7200 \text{ seconds}$$

$$\text{Cue Window} = 0.004 \text{ hours} = .24 \text{ minutes} = 14.4 \text{ seconds}$$

The Cue Window would be interpreted as follows. With a CWF value of 0.002, the CNA-200 would memorize the cue locations and wrap them in a 0.002 window. If an end cue was sensed at the 2 hour mark, the window would be 2:00:00 +/- 7.2 seconds for a total window of 14.4 seconds.

Illustrated it would look like this:

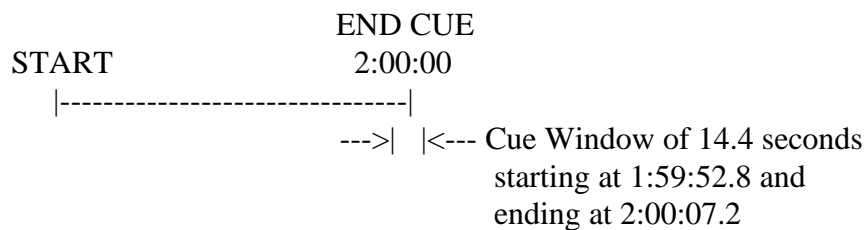

Given a normal 2 hour presentation with four cues, we could establish a table indicating their respective time locations.

| Name | Cue | Time from Start |
|---------|-----|-----------------|
| Trailer | 1 | 0:02:15 |
| Show | 2 | 0:06:32 |
| Credits | 3 | 1:48:26 |
| End | 4 | 2:00:00 |

Utilizing the same CWF value for each cue, the CNA-200 would construct a cue window table.

| Name | Cue | Time from Start | Cue Window | | |
|---------|-----|-----------------|------------|---------|-----------|
| | | | Start | End | Size |
| Trailer | 1 | 0:02:15 | 0:02:15 | 0:02:15 | 0.3 sec. |
| Show | 2 | 0:06:32 | 0:06:31 | 0:06:33 | 0.8 sec. |
| Credits | 3 | 1:48:26 | 1:48:13 | 1:48:39 | 13.0 sec. |
| End | 4 | 2:00:00 | 1:59:53 | 2:00:07 | 14.4 sec. |

Under normal conditions the CNA-200 will only recognize cues within the four established windows. If none are sensed it automatically inserts one at the end of a window which maintains your professional presentation. If cues are sensed outside the windows, they are assumed false and ignored.

The value of the cue window factor is determined by analyzing your local utility company's power fluctuations. This is done with the CNA-200. Simply keep the unit in the Cue Learn Mode for several days. After each presentation of the same show, record the cue values displayed in the Cue Learn setup screen.

To analyze the values, determine the maximum fluctuation in overall run time.

EXAMPLE:

LEARNED CUE VALUES

| Cue | Show 1 | Show 2 | Show 3 | Show 4 | etc. |
|-------|---------|---------|---------|---------|-------|
| Cue 1 | 0:01:00 | 0:01:00 | 0:01:01 | 0:01:01 | ----- |
| Cue 2 | 0:04:00 | 0:04:00 | 0:04:01 | 0:04:01 | ----- |
| Cue 3 | 1:45:00 | 1:45:14 | 1:45:08 | 1:45:34 | ----- |
| Cue 4 | 1:55:00 | 1:55:16 | 1:55:09 | 1:55:36 | ----- |

The widest fluctuation would be between shows 1 and 4. To estimate the CWF value, calculate the average fluctuation in run time by simply subtracting the low overall run time from the high overall run time (1:55:36 minus 1:55:00) and divide by 2. Then divide this number by the average run time [(1:55:36 + 1:55:00) divided by 2].

The result is as follows:

$$\begin{aligned}\text{Average fluctuation} &= (\text{HIGH VALUE} - \text{LOW VALUE}) \text{ divided by } 2 \\ &= (1:55:36 - 1:55:00) \text{ divided by } 2 \\ &= (0:00:36) \text{ divided by } 2 \\ &= 18 \text{ seconds}\end{aligned}$$

The average run time is simply calculated as follows:

$$\begin{aligned}\text{Average run time} &= (\text{HIGH VALUE} + \text{LOW VALUE}) \text{ divided by } 2 \\ &= (1:55:36 + 1:55:00) \text{ divided by } 2 \\ &= 3:50:36 \text{ divided by } 2 \\ &= 1:55:18 \text{ or } 1 \text{ hour, } 55 \text{ minutes and } 18 \text{ seconds}\end{aligned}$$

The deviation is calculated as follows:

$$\begin{aligned}\text{Deviation} &= \text{AVERAGE FLUCTUATION} / \text{AVERAGE RUN TIME} \\ &= 0:00:18 / 1:55:18 \text{ (convert to seconds)} \\ &= 18 \text{ seconds} / 6918 \text{ seconds} \\ &= .002602\end{aligned}$$

Your Cue Window Factor should not be less than the deviation. In our example the Cue Window Factor should not be less than 0.003.

We recommend adding 0.002 to the calculated three digit value. In our example the value in three digits is 0.005. A logical CWF should be 0.005.

The CWF value of 0.005 is logical in light of actual conditions. If you find lights coming up early at credits, you may wish to open the credit window up with a larger value. Remember, every 0.001 equals an increase in the window size of 3.6 seconds for every hour of movie length.

Our investigation indicates that power fluctuations normally represent a speed fluctuation of less than 0.1 percent (CWF value of less than 0.002).

Synchronous Operation

The CNA-200 systems are capable of running film synchronously in a multi-projector booth. The CNA-200 can be programmed for any one of twenty sync loops. This allows for up to twenty different sync loops on the network at one time. Pressing the Sync Mode key will activate the sync operation. To change the Sync Loop number, press [Menu][Set-up][Set-up Super], and enter either password. Set the loop number with the number keys.

Important: As a precaution, de-activate sync mode before changing the sync loop number. Changing loop numbers while sync is active may cause a fault to another machine that is running a show.

To run in sync the following conditions must be true:

1. A *sync cue* must be added to the beginning of the film. This is the first cue that is seen by the automation. It acts to initiate the start up sequence for each machine.
2. Sync Mode on each automation in the loop must be enabled.
3. The sync loop number on each automation in the loop must be the same.

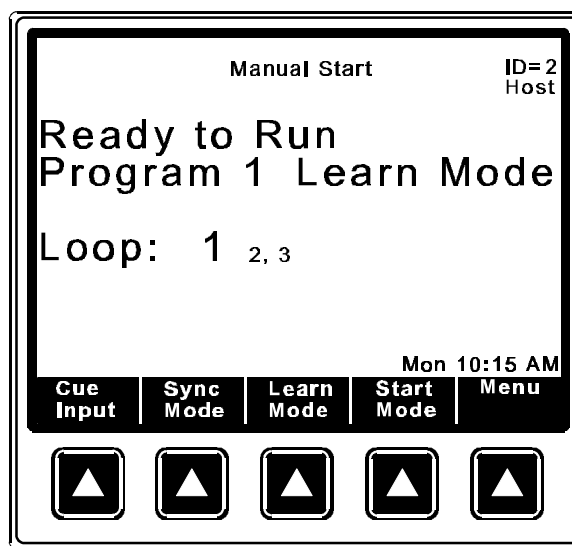

Figure 4.1

Figure 4.1 shows that Sync Mode is enabled. The Loop number is displayed in large text and the Id numbers on the sync loop are displayed in smaller text after the Loop number.

To begin a movie, insure that the sync cue is positioned somewhere before the cue

detector on the first machine. Press the [START] switch on any machine in the loop. All projectors will start simultaneously. As the sync cue passes through each projector, the show start sequence will initiate.

At the end of the show each machine will shut down independently as the tail of the film runs out of the projector. On endless loop systems all projectors will continue to run until the last machine see the end cue. At that time all projectors will shut down simultaneously.

Endless Loop Operation (Single Machine)

The CNA-200 makes *Endless Loop* operation simple and flawless. You will need a sync cue at the beginning of the film and a Wait Cue 0 instruction in the program (just as if you were running in sync). Position the sync cue before cue detector. Just as in sync interlock, this cue acts to initiate the start-up sequence. It is not necessary that the show be started at the precise same point in the film each time. The sync cue guarantees a perfect start that is consistent from show to show.

Running the Presentation

It is necessary that the operator be fully familiar with the CNA-200 and its features before running film. In particular, the Cue Learn feature and its use should be thoroughly understood. Initial running of each presentation, or of a film presentation that has been changed, should be conducted with the system in the Learn mode.

There may be times, either during a show or just testing the unit, where it may be necessary go from a "Ready to Resume" state to a "Ready to Run" state. As a convenience to the user, this can easily be done by pressing and holding the [STOP] key, and then pressing the [START] key until the display reads "Ready to Run". Release the [START] key first

System Fault and Status Messages

The CNA-200 has a list of fault status messages that can be displayed due to various internal or external conditions. Most of these messages displayed indicate system faults. There are also some internal power up and reset diagnostic messages, most of which will not and should not be displayed under normal operating conditions.

Fault Condition Messages

The Fault Condition messages can be divided into three categories: Internal *memory* faults, *run-time* faults and *failsafe* faults.

Memory Faults

The internal memory faults are generated when there is a "checksum" error. Briefly, a checksum is an arithmetic sum of the contents of memory that is stored in the memory itself and is re-computed and checked each time the CNA-200 is **powered up**. Each of the Programs (1 through 9), Supervisory, Cue Learn Times and Clock Start Times have a checksum. The fault messages are displayed and "blinked" on the top line of the display. Following are a list of the memory faults the CNA-200 can display.

```
SUPERVISORY MEMORY FAULT
CLOCK START TIMES MEMORY FAULT
PROGRAM 1- 0 MEMORY FAULT
PROGRAM 2- 0 MEMORY FAULT
PROGRAM 3- 0 MEMORY FAULT
PROGRAM 4- 0 MEMORY FAULT
PROGRAM 5- 0 MEMORY FAULT
PROGRAM 6- 0 MEMORY FAULT
PROGRAM 7- 0 MEMORY FAULT
PROGRAM 8- 0 MEMORY FAULT
PROGRAM 9- 0 MEMORY FAULT
LEARN TIME MEMORY FAULT
```

Supervisory Memory Fault

A *Supervisory* memory fault indicates a checksum error in the Supervisory set-up data. Clear the fault message by pressing the ALARM CANCEL key. Enter the Set-up Supervisory screen and verify the Supervisory data. If necessary, edit to correct any data. Press the Home key to re-calculate the checksum and return to

the Run Mode Screen. Cycle power to verify that there is no other checksum errors.

Clock Start Times Memory Fault

A *Clock Start Times* memory fault indicates a checksum error in the Clock Start times. Clear the fault message by pressing the ALARM CANCEL key. Enter the Set-up Clock Start Times screen and verify the start times for each day of the week. If necessary, edit to correct any data. Press the Home key to re-calculate the checksum and return to the Run Mode Screen. Cycle power to verify that there is no other checksum errors.

Program dd-dd Memory Fault

If any of the *Program* memory faults are displayed on power up, *clear* the fault message by pressing the ALARM CANCEL key. Enter the Set-up Program screen and select the program that has the fault. Scroll through the program to verify it. If all the steps look okay, press the Home key to re-calculate the checksum and return to the Run Mode Screen. Cycle power to verify that there is no other checksum errors.

Learn Time Memory Fault

A *Learn Time* memory fault indicates a checksum error in the saved Cue Learn times. Clear the fault message by pressing the ALARM CANCEL key. Enter the Set-up Cue Learn Times screen and verify the learn times for each program. If necessary, edit to correct any data. Press the Home key to re-calculate the checksum and return to the Run Mode Screen. Cycle power to verify that there is no other checksum errors.

Run-Time Faults

These messages will be displayed if there are the following network communications faults.

LOCAL I/O NETWORK FAULT
SYNC INTERLOCK FAULT ID=XX
SYNC COMMUNICATIONS TIMEOUT ID=XX

Local I/O Network Fault

The *Local I/O Network Fault* is caused due to a loss in communications with a Local I/O Network device or another network problem. This could be the Booth Termination Panel, Console Termination Panel or other I/O Network device, or a

wiring problem. This fault will cause a shutdown during a show or prevent a show start between shows. This fault is latched and you are required to press the ALARM CANCEL key to clear the fault. Although this will cancel the fault and allow a show to start, there is a problem with the Local I/O Network or one of the devices and it must be repaired. See the Troubleshooting section for possible causes of this fault.

Sync Interlock Fault

Sync Interlock Fault ID=XX is displayed when either a master or one of the slaves in the sync loop has lost its sync input (sync switch). All CNA-200s on the sync loop will display this message and sound their alarms. This message will also be displayed if one of the units on the loop had a "watchdog reset". If this was the case, all units will display this message except for one that had the watchdog reset.

Sync Communications Fault

Sync Communications Fault ID=XX is displayed when there is a loss of communications with a unit on the sync loop. This could be due to a loss of power of the master or one of the slaves on the loop. In this case all units on the sync loop would display this message except for the one that lost its power. This fault can also be caused by defective wiring, such as an open or short on the communications link.

Failsafe Faults

There are a number of local and synchronous failsafe faults that will shutdown a show that is running or prevent a show from starting or resuming.

Local Failsafe Faults

This is a list of messages that can be displayed due to one of the failsafe faults.

FILM PRESENCE OR TENSION FAULT
FILM MOTION FAULT
XENON LAMP FAILURE FAULT

Film Presence or Tension Fault

This fault indicates that the film failsafe does not sense film presence or the film tension is excessive. Correct the problem to clear the message.

Film Motion Fault

This fault indicates that the film motion sensing device did not detect the proper film speed after 2 seconds. Press the ALARM CANCEL key to clear the message.

Xenon Lamp Failure Fault

This fault indicates that the xenon lamp failed to light after 10 seconds. Press ALARM CANCEL to clear the message.

Sync Interlock Failsafe Faults

This fault indicates the master or one of the slave CNA-200s has a failsafe fault that is preventing the interlock loop from *resuming* a show. The following messages are displayed to indicate the fault.

SYNC ID=*dd* NOT READY TO RUN
SYNC ID=*dd* NOT READY TO RESUME
SYNC: NEED MASTER TO RESUME
SYNC REMOTE STOP FAULT

Where *dd* is the remote CNA-200 ID number (1 through 63)

Sync ID=*dd* Not Ready to Run

This fault indicates that the automation can not start a show because at least one of the CNA-200 remotes are not in the “Ready to Run” condition.

Sync ID=*dd* Not Ready to Resume

This fault indicates that the automation can not start a show because at least one of the CNA-200 remotes are not in the “Ready to Resume” condition.

Sync: Need Master to Resume

There is no master. The master may be lost if the communication wires are disconnected, power is lost or the sync input (sync switch) is not enabled at the master.

Sync Remote Stop Fault

Indicates a fault on a remote CNA-200 when interlocked. Correct the problem to clear the message.

Status Messages

Status messages serve as a reminder that a particular action or service be performed. These messages will not prevent the CNA-200 from operating normally. Following is a list of messages the CNA-200 can display.

MAINTENANCE SCHEDULE A FAULT
MAINTENANCE SCHEDULE B FAULT
MAINTENANCE SCHEDULE C FAULT
MAINTENANCE SCHEDULE D FAULT
MISSED CUE X
CHECK CUE LEARN TIMES
REMOTE ALARM AT ID:dd
FAULT DEFEAT ENABLED
LOW BATTERY FAULT

Maintenance Schedule Fault

This status message indicates the maintenance is required for schedule A, B, C or D. Reset the timer in Supervisory when maintenance has been performed. You must reset the timer in Supervisory, by pressing 1 2 3 4 CLEAR, to clear the message.

Missed Cue

This message indicates that specific cue inputs were not received by the cue detector and an automatic cue was issued (Learned Mode). This indicates the film cues may be worn or missing. Clear the message by pressing the ALARM CANCEL key. This message may be suppressed with a setting in the Supervisory.

Check Cue Learn Times

This message is displayed after a show is run in Cue Learn Mode. This is a reminder to view and verify the Learn times. Clear the message by pressing the ALARM CANCEL key. This message may be suppressed with a setting in the Supervisory.

Remote Alarm at ID:dd

This message indicates a Fault - Alarm condition at remote CNA-200, where dd is the ID number.

Fault Defeat Enabled

This message serves as a reminder to the operator that the Film Presence, Film

Motion, Film Tension and Xenon Faults are bypassed. Set the Fault Defeat to Disabled to clear the message.

Low Battery Fault

Low battery fault indicates that the battery has gone below a pre-determined threshold voltage during a power down condition. If this message is displayed along with any *memory fault* messages, the low battery condition probably caused the other memory fault(s).