

TABLE OF CONTENTS

PREFACE	1
FIGURE 1	2
FIGURE 2	3
INSTALLATION	
Unpacking	4
Mounting	4
Lamphouse Alignment	5
Wiring Instructions	5
Lens Installation	6
THREADING	8
THREADING DIAGRAM	9
INITIAL OPERATION	10
MAINTENANCE	12
FIGURE 3	14
FIGURE 4	15
ADJUSTMENTS AND REPLACEMENTS	
Intermittent Shoes	16
Gate Pressure Pad	16
Film Trap	16
Trap Pressure Straps	16
Lateral Guide Rollers	17
Studio Guides	17
Film Gate Support	17
Film Sprockets	17
Pad Rollers	18
Fire Shutter	18
Shutter Shaft	18
Vertical Shaft	19

TABLE OF CONTENTS (continued)

ADJUSTMENTS AND REPLACEMENTS (continued)

Shutter Timing 19
Main Drive Shaft 20
Framing Lamp 20
Lens Turret 20
Lens Positioning 21

INTERMITTENT MOVEMENT

Removal 22
Installation 22
Intermittent Sprocket Replacement 23
Sprocket Shoe Assembly 23
Camshaft End Play 23
Star and Cam Spacing 24

SUPPLEMENTAL PARTS LIST

Lens Turret 26

STRONG INTERNATIONAL

a division of Ballantyne of Omaha, Inc.

4350 McKinley Street

Omaha, Nebraska 68112

February 1998

PREFACE

THE CENTURY 35mm TURRET PROJECTOR combines rugged construction with ease of operation, providing a superior mechanism for the modern cinema. High engineering standards in manufacturing, and a worldwide network of support through Strong International Dealers, insure long years of dependable operation.

A SINGLE-UNIT CAST MAIN FRAME provides a sturdy foundation for all moving parts. The roomy film compartment permits ease of threading and cleaning. The gear compartment is accessible behind a hinged access door. The Century lens turret is available in either Automatic or Manual configuration, and no Magnacom lens is required for either turret. The turret is securely anchored to the main frame to insure holding lenses on optical center. Each lens may be individually fine focused by means of separate control knobs. A dual aperture plate incorporates both anamorphic (CinemaScope) and "flat" formats.

THE TU2020C AUTO TURRET accommodates standard (72mm diameter) lenses and features a motor-driven dual aperture plate for fast, quiet format changes. The optional TU2030C Turret makes provision for a third "special" lens and aperture. A solid-state control module mounts directly to the turret.

ALL FILM-BEARING COMPONENTS are designed to minimize print wear and to simplify routine maintenance. The curved film gate and trap can be quickly removed without tools to encourage frequent cleaning. Gate tension can be adjusted while the machine is running. Lateral guide rollers and studio guides mounted to the trap minimize "side weave." VKF® (Very Kind to Film) sprockets are used exclusively.

THE INTERMITTENT MOVEMENT runs in a sealed oil bath for constant lubrication. The oil level is visible through a sight glass on the operator's side of the mechanism in the film compartment. Framing is accomplished by raising or lowering the movement on a rack and pinion operated by a front-mounted knob. The spring-loaded intermittent shoes are adjustable independent of the gate tension to minimize picture "jump" without applying excessive gate tension.

THE SHUTTER BLADE is positioned close to the aperture for maximum light efficiency. Air vanes on the shutter blade aid trap cooling. Optical design is compatible to modern xenon lamphouse systems.

ALTHOUGH the Century Projector was designed for use with the Series R-3 or MR-3E Optical Soundhead, other type soundheads may be used without loss of performance.

OPTIONAL ACCESSORIES available for Century Projectors include water-cooled film traps, double shutters, and heat filters.

VKF® is a registered trademark of LaVezzi Precision Incorporated, Elmhurst, Illinois.

Run Halftone FIGURE 1
(page 2)

Run Halftone FIGURE 2
(page 3)

INSTALLATION

EACH CENTURY PROJECTOR is carefully inspected and film-tested before leaving the factory. Carefully inspect the unit on receipt for any shipping damage, and file any damage claims with the freight carrier immediately. It is the responsibility of the consignee, not Strong International, to file such claims.

THE FOLLOWING RECOMMENDATIONS should be studied carefully prior to installation. Your Strong International Dealer may wish to assist in installing those items supplied by him.

UNPACKING

The Century Projector is shipped in a sturdy wooden crate. Remove the (2) crate sections marked TOP and OPEN THIS END. The projector is secured to the base of the crate by (2) 3/8-16 hex head screws. If shipped as an "All-In-One" system (assembled to the Series R-3 or MR-3E Soundhead), the soundhead is mounted to the base of the crate with (2) 5/16-18 hex head screws.

An accessory kit is shipped with each Century projector. This kit includes the following:

- (1) Bottle Century Projector Oil OL-0004
- (1) Soundhead Damping Fluid FD-0120
- (1) Tube Century Gear Lubricant TU-0380
- (1) Set Allen Wrenches 21-98215
- (1) Framing Lamp Transformer TF-0368

The tools and accessories are required for routine adjustments and preventative maintenance after installation. Store them in a secure location in the projection booth.

MOUNTING

Four holes in the back of the soundhead casting are tapped 3/8-16 and mate to the four mounting holes of a standard projector/soundhead mounting arm of a projection pedestal or projection console. The mounting screws (SC-0600) and washers (WA-0105) are supplied.

When not shipped as an "All-In-One" system, the soundhead must be secured to the mounting arm before the projector is installed. The top surface of the Century Soundhead has (2) 3/8" clearance holes and (2) 3/8-16 tapped holes which correspond to mating holes on the base of the Century projector. It is recommended to use (4) 3/8-16 fasteners to secure the projector mechanism to the soundhead.

Remove the drive side cover casting from the off-operator side of the soundhead. Install the flywheel (WH-0072) to the impedance drum shaft, with the hub of the flywheel facing *in* (toward the mechanism). Tighten the fastening screw securely. Install drive belt(s) and set belt tension by sliding the drive motor on its slotted mounting holes. Replace the soundhead cover casting after installing drive belt(s).

MOUNTING (continued)

Add the Century Damping Fluid (FD-0120) supplied to the cup of the damper assembly in the soundhead. The damper assembly is located below the slit lens and impedance drum. Loosen the fluid cup fastening screw (SC-0526), which will allow the cup (CU-0085) to be removed at the bottom. Fill the cup with damping fluid to the groove cut into the inside of the cup. Replace the cup into the assembly, raising the cup all the way up to the shoulder, and tightening the cup fastening set screw SC-0526 securely.

Check the oil level of the intermittent movement and add oil as required. The oil level is visible through the sight glass below the intermittent sprocket. Fill to the red line using the Century Projector Oil supplied. The oil fill cup is located on the arm behind the intermittent sprocket. Do not fill *over* the level indicated. Excess oil will be expelled through the vent holes and the fill cup when the projector is started, and may deposit on the film. USE ONLY GENUINE CENTURY PROJECTOR OIL.

R3, MR-3 SOUNDHEAD

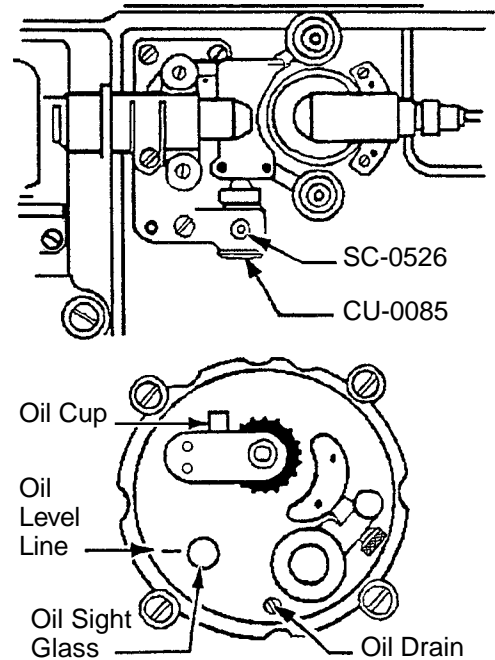

LAMPHOUSE OPTICAL ALIGNMENT

Carefully follow the lamphouse manufacturer's instructions regarding correct optical alignment between the lamphouse and projector. The lamphouse is generally aligned to the projector aperture, but some consoles require positioning the projector and soundhead to the optical center of the lamphouse. DO NOT alter the film path between the projector and soundhead in the course of these adjustments. DO NOT operate the lamphouse with the douser open unless the projector is running.

LAMPHOUSE LIGHT SHIELD

Light shields, or nose cones, are frequently supplied by the lamphouse manufacturer. These may be installed between the projector shutter guard and the lamphouse snood. Make certain that the nose cone does not obstruct the rotation of the shutter blade. Trim or otherwise modify the nose cone as required.

WIRING INSTRUCTIONS

Connect the exciter lamp to a listed power supply. The incandescent exciter lamp used in a direct scan soundhead operates on 9 volts, 4 amperes DC. AC exciter output is generally an emergency backup provided by many exciter power supplies. The L.E.D. exciter used for analog reverse scan soundheads, and/or the quartz lamp used for digital sound scanning, connect to the special power supply furnished with the soundhead. See the soundhead manual for hookup instructions and adjustment procedures. It is highly advisable to have the soundhead alignment checked by a qualified sound technician to correct any adjustments which may be disturbed in shipping.

WIRING INSTRUCTIONS (continued)

All electrical connections to the projector head terminate in the Control Cabinet mounted at the front of the projector adjacent to the turret hinge. Remove the (2) cover plates to expose the terminals.

Input voltage is user-selectable by connecting the transformer plug to one of the two receptacles located on the top of the lower printed circuit board. Connect the plug to J7 for 110 volt operation, or to J8 for 220 volt. After selecting the voltage, apply AC phase and neutral to the (2) uppermost terminals on the right barrier strip. An earth ground must be connected to the ground terminal at the lower right of the lower printed circuit board. This AC input powers the turret controller and the turret and aperture motors.

The lower terminals of the right barrier strip allow connections from the automation controller to the picture changeover and the sound-head drive motor. The left barrier strip provides connection points to the devices. Voltage to these devices is generally supplied by, or switched through, the automation controller. All NEUTRAL connections are common.

Picture Changeover

The Century projector is normally supplied with either an Essanay ("Zipper") or Strong International 120 V.AC (82-60218), 230 V.AC (82-60219) or 24 V.AC (82-60283) picture changeover device. If ordered separately, connect the changeover leads as follows:

Zipper

Blk - OPEN
Brn - CLOSE
Wht - COMMON

Strong

Blk - OPEN
Red - CLOSE
Wht - COMMON
Grn - GROUND

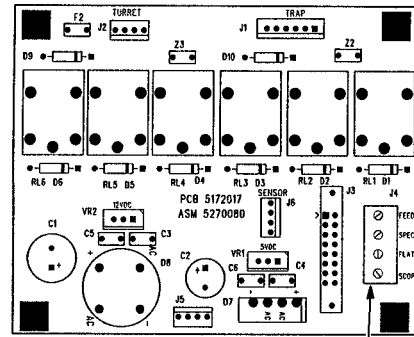

Upper PC Board: Turret Inputs

Transformer not shown

Lower PC Board: AC Input

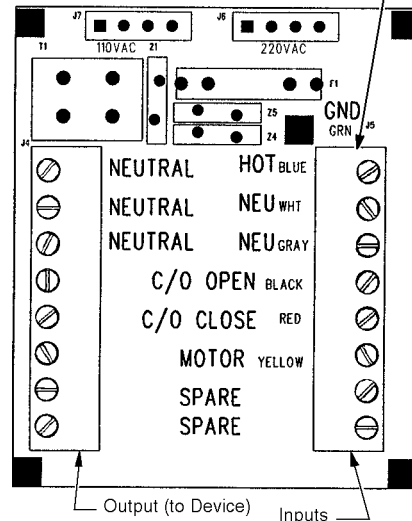

Output (to Device)

Inputs



NOTE: These changeover devices require a 120 V.AC *pulse* to operate. Connecting the changeover to a *sustained* 120 V.AC supply will **destroy** the electrical coil. Check carefully the instructions supplied with the automation controller or the (installer supplied) switching circuit.



The MANUAL turret requires no electrical connections. Installer connections to the AUTOMATIC turret are made to terminals located in the control box adjacent to the turret on the front of the projector. The FLAT, SCOPE, and SPECIAL inputs are derived from an automation controller and/or other installer-supplied circuitry. NOTE: "SPECIAL" input applies only to a third lens in a three-lens turret.

WIRING INSTRUCTIONS (continued)

A stepdown transformer (TF-0368) is provided to supply low voltage (12 V.AC) to the projector framing lamp. Mount the transformer to the projection pedestal or console and apply 120 V.AC to primary terminals 1 and 4; jumpers between 1 & 2 and 3 & 4 (see wiring instructions on the transformer). Connect the 12 V.AC secondary to the framing lamp leads.

LENS INSTALLATION

The lens barrels are individually marked to designate their screen format. The barrels of the standard two-lens turret are marked SCOPE (CinemaScope, or anamorphic) and FLAT (wide screen, non-anamorphic). The additional barrel in the three-lens turret is marked SPECIAL. The lenses must be installed in the correct barrels for correct aperture logic. Magnacom lenses are not required in any configuration.

Rotate the turret to the SCOPE position. The automatic turret will index to this position after the SCOPE switch is pressed; the manual turret must be indexed by hand. Make certain the SCOPE aperture plate is in position. Center the focus adjustment screw, allowing equal travel forward and back. Insert the CinemaScope lens and anamorphic adapter into the SCOPE barrel. Start the projector, ignite the lamphouse, and project a picture to the screen. Move the lens inside the barrel until a sharply focused picture is projected, and the anamorphic correction is on the correct horizontal plane. Securely tighten the lens locking knob on the top of the SCOPE barrel. Close the lamphouse douser.

Reset the turret to FLAT format, and make certain the FLAT aperture is in position. Center the focus adjustment screw, and insert the FLAT lens. Open the lamphouse douser and move the lens inside the barrel until a sharply focused picture is projected. Tighten the lens locking knob above the FLAT barrel.

Repeat the above procedures as required for the "special" lens used in a three-lens turret. Once installed, DO NOT remove the lenses for cleaning. The turret is hinged, and opens to permit cleaning the rear surfaces of the lenses.

Two round steel bushings are located at the top of the aperture changer and are mounted with small (4-40) socket head screws. These bushings serve as stop pins to limit the travel of the aperture plate. The (2) bushings are eccentric, and furnish a slight degree of adjustment by loosening the socket head screws and rotating the bushings. Make certain the aperture travel is acceptable, and the bushings are secure, before filing the aperture plate.

To remove the aperture plate for filing, loosen the captive quarter-turn wing-head screw securing the aperture plate to the slider bracket. Allow the hinged portion of the slider bracket to drop, and withdraw the aperture plate from the trap. File the aperture openings to size the picture to the screen and/or masking.

NOTE: When projecting a white light while filing apertures, close the lamphouse douser *frequently* to allow the lens to cool.

DO NOT attempt to correct "keystoning" by shimming the turret or offsetting the position of the lenses. The lenses must be positioned on optical center to project a satisfactory image.

THREADING

THREADING THE PROJECTOR *correctly* before each presentation is one of the operator's most important duties. Careful attention during this operation pays off in improved performances and long print life.

IT IS HIGHLY RECOMMENDED to clean the gate and trap prior to each threading operation. Loosen the knurled-head screw pressure pad retaining screw, and remove the gate pressure pad assembly. Use a clean, dry cloth to wipe down all film-bearing surfaces of the gate and trap. After cleaning, replace the pressure pad assembly (note "TOP" marked inside runners) and secure the retaining screw fingertight.

PICTURE FRAMING on the Century projector is achieved by raising or lowering the intermittent movement, thus raising or lowering the film frame on the picture aperture. Rotation of the FRAME knob on the front of the projector, below the lens turret, causes the intermittent to travel up or down. Press the spring-loaded FRAME knob in to engage the gear train, and rotate back and forth. Observe the upper and lower limits of intermittent travel, and position the intermittent at the center of its travel. This will insure adequate movement up or down to correct accidental misframes. Always "center" the intermittent in this manner before threading.

ROTATE THE MOTOR FLYWHEEL and observe the intermittent sprocket. Unlike the feed and holdback sprockets, the intermittent sprocket rotates in steps of (4) perforations. Turn the motor flywheel until the intermittent sprocket stops after one of these steps.

OPEN THE FILM GATE by pulling the gate release pin. Open the upper and lower pad roller assemblies. Open the intermittent sprocket shoes. Turn on the framing lamp (toggle switch on top of projector).

THREAD THE FILM under the upper feed sprocket, over the upper pad roller, and through the film gate. Engage the film on the intermittent sprocket while viewing the framing aperture. The turret may be opened to improve the view of the framing aperture. Center a frame of the protection leader in the framing aperture, and close the intermittent sprocket shoes. Close the film gate by pressing it into the trap until the release pin latches. Swing the turret closed and make certain that the latch engages.

ENGAGE THE FILM with the upper feed sprocket, form a loop using the upper pad roller in its open position, and close the upper pad roller. Thread under the lower pad roller assembly and over the lower holdback sprocket. Engage the film with the holdback sprocket, form a loop using the lower pad roller assembly in its open position, and close the lower pad roller.

TURN THE MECHANISM by hand to advance a few frames of film. **Do not turn the projector motor on and off to check threading. If the film is not threaded properly, film damage may occur.** Run fingers over each sprocket to insure that the sprocket teeth are centered in the film perforations, and the film is centered between the pad roller flanges. Check again the position of the film in the framing aperture (open the turret if required). A correct frame image in the framing aperture insures correct frame positioning on the picture aperture. Use the framing knob to correct misframes. Make certain the turret is securely closed and latched.

THREAD THE SOUNDHEAD as detailed in the soundhead instruction manual. Take up any slack between the projector and the film transport; a slight degree of film tension is required above the feed sprocket and below the soundhead. This prevents the film from snapping upon motor start.

THREADING DIAGRAM
Century Turret Projector

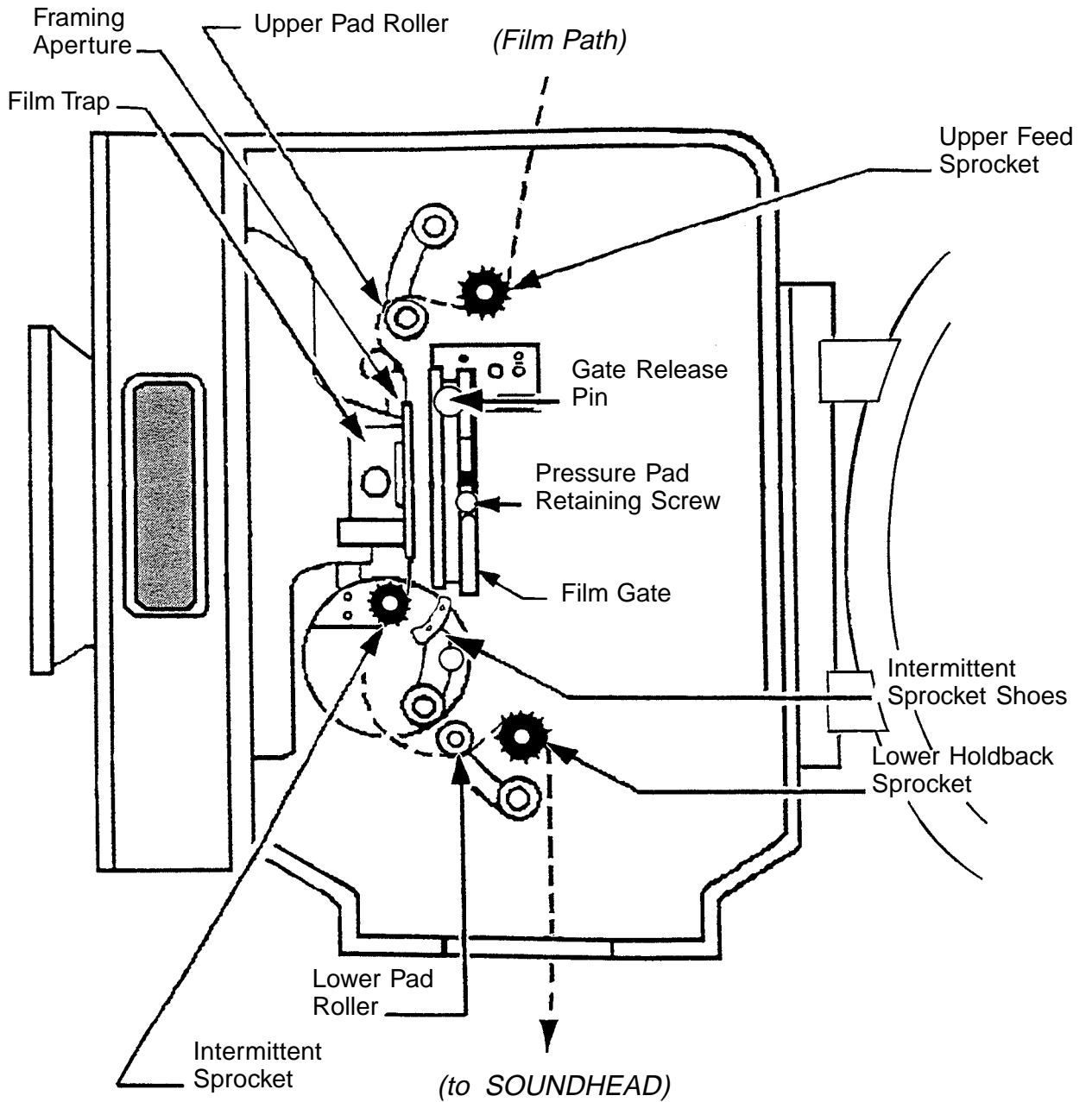

INITIAL OPERATION

CLEAN ALL FILM-BEARING SURFACES PRIOR TO THREADING. Check all sprocket teeth for hooks or burrs; replace if required. Keep all pad rollers clean and operating freely. Make certain the turret is set to the correct lens and aperture for the desired screen format. FLAT format is generally used for initial set-up of the projection system.

THE FILM TRAP TENSION KNOB is located at the top of the film trap. Rotate the knob to position the white line pointing straight up (12:00 o'clock). This position indicates minimum trap tension. Thread film into the projector, ignite the lamp, open the douser, and project a picture to the screen. Use of RP-40 test film is highly desirable for this stage of machine set-up. This test film may be purchased directly from the Society of Motion Picture and Television Engineers:

SMPTE Test Film Department
595 West Hartsdale Avenue
White Plains, New York 10607

Order: 35 PA-50 (50 ft.)
or 35 PA-200 (200 ft.)

INSTALL THE PROJECTION LENSES and set focus as detailed in the preceding INSTALLATION section. File the apertures to fit screen masking; the aperture plate is secured to the drive assembly by a wing-head quarter-turn screw. Position and tilt the pedestal or console as required to center the picture on the screen.

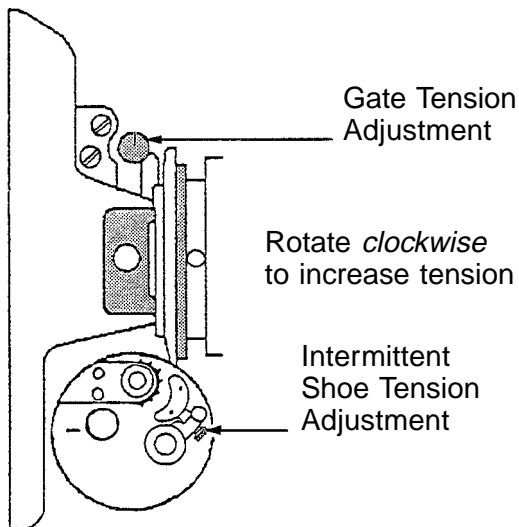

IF THE PROJECTED PICTURE is unsteady, rotate the film trap tension knob *gradually* in a clockwise direction, while the film is running. To remove picture "jump," adjust the intermittent shoe tension. Always adjust for the *minimum* tension required to project a steady picture. Excessive gate tension not only creates distracting transport noise and increased wear on parts, but in extreme cases may cause torn film perforations and may contribute to print wear and breakage.

CHECK THE PROJECTED PICTURE for flicker or travel ghost. "Travel Ghost" is the term commonly applied to vertical streaking of lighter areas against a darker area, and is particularly noticeable during opening or closing titles and credits. This indicates that the shutter is out of time. The shutter is carefully timed at the factory, but the setting may be disturbed by vibration in shipping. To reset the shutter, see "Shutter Timing" in the ADJUSTMENTS AND REPLACEMENTS section following.

INITIAL OPERATION (continued)

REPEAT THE PROCEDURE using the SCOPE lens and aperture. Observe the position of the picture on the screen. If the SCOPE picture is higher or lower than the FLAT picture, or if the image shifts to the left or right, it will be necessary to adjust the position of one or both of the lens barrels. See the ADJUSTMENTS AND REPLACEMENTS section following (LENS TURRET, Steps 3 and 4) for detailed instructions.

THE ROTATION TRAVEL of the lens turret is limited by the indexing stop pin mounted to the outer ring of the turret. The automated turret includes a solenoid which pulls the pin when the turret is in motion. Two coil expansion springs seat the pin when the turret is at rest. When first energized, the autoturret will automatically index to FLAT mode, if not already in FLAT. The sensor switch on the turret ring will detect the cueing magnet(s) mounted to the index stop bracket and set the correct aperture (one magnet mounted inboard = FLAT, one magnet mounted outboard = SCOPE, two magnets = third lens). L.E.D. indicator lights on the front panel of the control cabinet display detection of the magnets; both lights glowing simultaneously indicates "third lens" aperture setting.

IN THE EVENT of a turret motor failure, the automatic turret can be operated manually until a replacement motor is obtained. A lever on the solenoid housing allows withdrawing the index stop pin manually. Do not index the turret by grasping the focus knobs; lens focus will be altered. The aperture plate can be pushed in or pulled out manually to set the correct format. It is advisable to de-energize the turret control module until the replacement motor is installed.

MAINTENANCE

WITH PROPER MAINTENANCE, the Century Projector will deliver many years of trouble-free operation. The following is the recommended maintenance schedule for the Century Projector. Contact your authorized Strong International Dealer for the required lubricants and other supplies.

DAILY:

1. Before starting the projector, check the intermittent oil level. When the projector is not running, the oil level should be at, but not higher than the red line on the intermittent case. Add Century Projector Oil as required.
2. Open the film gate. Loosen the knurled-head pressure plate mounting screw and remove the gate pressure pad assembly. Using a soft, dry cloth, wipe down all film-bearing surfaces of the gate and trap. Replace the pressure pad assembly (NOTE: "TOP" marked on inside of plate).
3. Clean the sprockets and rollers with a soft brush. A clean, used toothbrush is ideal for this purpose.
4. Wipe out any dust, film residue, or oil accumulation.

WEEKLY:

1. Check the setting of the pad rollers. Allow two film thicknesses of clearance between the pad rollers and the faces of the film sprockets.
2. Open the gear compartment. Brush a little Century Gear Lubricant (Part No. TU-0380) on the surfaces of the gears. Wipe off excess build-up.

MONTHLY:

1. Add a drop or two of Century Projector Oil to the starwheel shaft outer bushing. The oil hole is in the intermittent outboard arm adjacent to the intermittent sprocket.
2. Add a few drops of Century Projector Oil to the oil cups above the upper and lower sprocket shafts in the film compartment.

EVERY THREE MONTHS:

1. Inspect the sprocket teeth for burrs or hooks. For normal (forward-only) operation, a "hooked" sprocket may be reversed on its shaft and re-used.
2. Check the pad rollers for free movement. Rollers should show even wear with no flat spots; roller flanges should be rounded with no cuts. Replace if required.

MAINTENANCE (continued)

EVERY THREE MONTHS (continued)

3. Check the grease around the main drive shaft. If it is dirty or dark in color, clean it out and replace with new Century Gear Lubricant (TU-0380). Make certain that the inner surfaces of the gear teeth are lubricated.
4. Dismount and carefully inspect the film trap. The film trap shoes (straps) are subject to periodic replacement and must be free from scratches, burrs, and excessive wear. The lateral guide rollers at the top of the trap must be clean and rotating freely. The studio guides should be positioned to accept all conditions of film.

YEARLY:

1. Drain the intermittent oil. When removing the drain screw, note the sequence of installation of the (3) washers. Replace the drain screw and all (3) washers in the correct sequence illustrated (fibre washer against intermittent case) to prevent oil seepage. Replace the oil using only genuine Century Projector Oil; DO NOT OVERFILL.
2. It is a good mechanical practice to periodically check the equipment and make certain that all retaining and fastening screws and nuts, collars, gears, pulleys, couplings, etc. are tight and have not worked loose in the course of normal operation.
3. Inspect drive belts for proper tension. Timing belt tension should be sufficient to allow the belt cogs to firmly engage the pulley teeth, but *do not overtighten*. Excessive belt tension can damage shafts and pulleys, and may cause premature bearing failure. Replace the drive belt(s) if cracked or worn.
4. Check fittings and hoses on water-cooled systems. Replace coolant if required (4:1 ratio of distilled water to all-weather antifreeze).

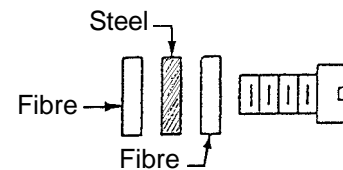

LIGHT LUBRICATION of the gate pressure pad and the trap shoes is permitted after cleaning for smoother and quieter operation. Use a commercially available film lubricant such as XeKote® or equivalent. DO NOT OVERLUBRICATE. Excessive lubrication will attract and hold dust and film residue.

A TRAP ALIGNMENT GAUGE (Part No. C1-E-30) is available from your Strong International Dealer. It may be used to check the alignment of the film trap to the intermittent sprocket.

Run Halftone FIGURE 3
(page 14)

Run Halftone FIGURE 4
(page 15)

ADJUSTMENTS AND REPLACEMENTS

REFER TO THIS SECTION in conjunction with following the routines outlined in the MAINTENANCE section. Conscientious service and preventative maintenance of the Century Projector will insure many years of excellent performance.

ADJUSTMENTS are quickly accomplished, and replacements performed, since all units and components are readily removed. Adjustments and replacements described below may be performed by qualified projection booth personnel. Any elements of maintenance and service not detailed below should be referred to an authorized Strong International Dealer.

INTERMITTENT SHOE REPLACEMENT

1. Open the intermittent shoe assembly. Using a 1/8" allen wrench, loosen the set screw (SC-0155) in the intermittent case immediately in front of the shoe assembly. Withdraw the intermittent shoe assembly from the film compartment. Replace worn components.
2. Check the coil spring for correct tension. To remove the coil spring, remove the small slotted round head screw which serves as a stop for the knurled tension adjusting nut. Unscrew the knurled nut and remove the spring. Stretch or replace the spring as required; reassemble.
3. When replacing the intermittent shoe assembly, allow the pointed set screw in the intermittent case to center into the corresponding hole in the shaft of the assembly. Securely tighten the set screw.

FILM GATE PRESSURE PAD REMOVAL

1. Loosen, but do not remove, the knurled-head screw at the center of the film gate. Remove the pressure pad assembly from the film compartment.
2. When replacing, note the top of the pressure pad runner plate is marked "TOP."

FILM TRAP REMOVAL

1. If removing the film trap from a water-cooled mechanism, it is not necessary to disconnect the water lines. Water cells are contained in the trap support gib assembly.
2. Open the film gate and unplug the aperture motor receptacle. Using a common (slotted) screwdriver, loosen the large knurled-head screw located on the trap behind the picture aperture. This is a "captive" screw, and need not be removed. When the knurled-head screw is disengaged from the trap support gib, withdraw the complete film trap and aperture changer assembly from the film compartment.
3. When replacing the film trap, engage the dovetail of the trap with the dovetail of the trap support gib. Slide the trap all the way inboard until the machined surfaces of the trap and the support gib mate firmly together. Start the knurled screw by hand to prevent cross-threading, and securely tighten with a screwdriver. Reconnect the aperture motor plug.

FILM TRAP PRESSURE STRAP REPLACEMENT

1. Always replace SH-1811 Pressure Straps in *matched pairs*. Rotate the film tension knob to its minimum tension setting (white line at 12:00 o'clock). Open the film gate and remove the film trap as instructed above.

ADJUSTMENTS & REPLACEMENTS (continued)

FILM TRAP PRESSURE STRAP REPLACEMENT (continued)

2. Remove the (4) strap mounting screws from the trap casting; (2) on top, (2) on bottom. NOTE: washers are used under the top (2) screws only. Install the replacement straps and tighten the (4) screws.

ALIGNMENT OF LATERAL GUIDE ROLLERS & STUDIO GUIDES

1. Open the film gate and remove the pressure pad. Dismount the intermittent shoe assembly.
2. The pivots of the lateral guide rollers are held by (2) hex head set screws at the top of the trap behind the framing aperture. Loosen these (2) set screws.
3. Place Century Alignment Gauge C1-E-30 on the intermittent, and push it onto the intermittent sprocket until the side plate touches the outside rim of the sprocket. Carefully push the gauge plate between the studio guides until it lays flat against the trap shoes (pressure straps).
4. When properly assembled, the *outboard* lateral guide roller is **fixed**, while the *inboard* lateral guide roller is spring-loaded and moves horizontally. Bring the fixed (outboard) guide roller into contact with the gauge plate and tighten the hex head pivot set screws.
5. Make certain that the inner surfaces of the studio guides are in contact with the outer edges of the gauge plate. This allows the proper clearance for the passage of film.
6. Replace the gate pressure pad and the intermittent sprocket shoe assembly.

FILM GATE SUPPORT REMOVAL

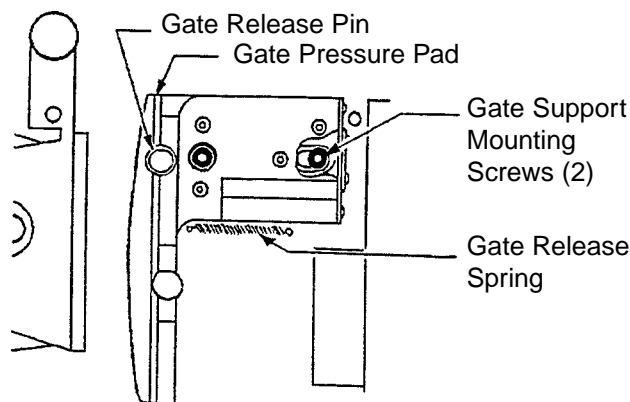

1. Open the film gate and remove the film trap. Close the film gate.
2. Remove the gate release spring at the bottom of the sliding ball bearing assembly.
3. Remove the (2) socket head gate support mounting screws recessed inside the bearing assembly and pull the support assembly straight out of the film compartment.
4. To replace the gate support, set the low-head socket screws through the recess of the bearing assembly and into the mounting block of the bearing assembly.
5. Replace the film trap. Set the distance between the trap and the gate by placing a 1/4" allen wrench or similar spacer between the trap studio guides and the gate pressure pad plate (gate in CLOSED position). Position the gate to be parallel with the trap studio guides. Tighten the (2) mounting screws.
6. Re-install the gate release spring and pressure pad assembly as illustrated.

FILM SPROCKET REPLACEMENT

1. Open the pad roller. Remove the sprocket retaining screw from the center of the sprocket. Pull the sprocket from its shaft.

ADJUSTMENTS AND REPLACEMENTS (continued)

FILM SPROCKET REPLACEMENT (continued)

2. To install the replacement sprocket, open the gear compartment door and hold the fibre sprocket shaft driven gear firmly against its bushing. Slide the replacement sprocket onto the sprocket shaft and press it against its bushing to remove end play. Replace and tighten the sprocket retaining screw.

PAD ROLLER REPLACEMENT & SERVICING

1. Pad roller assemblies can be dismantled as a unit by loosening the retaining set screws in the main frame. Loosen the set screw and withdraw the pad roller assembly from the film compartment.
2. To remove a pad roller, loosen the set screw at the end of the pad roller arm casting, and withdraw the pad roller shaft. Install the replacement pad roller on the shaft and return the shaft to the arm casting. Before tightening the shaft set screw, allow enough end play to center the pad roller over the sprocket without the roller flanges touching the edges of the sprocket.
3. Set the pad roller arm in its CLOSED position and return the pad roller assembly to the film compartment. Rotate the pad roller assembly and rest it against its stop over the sprocket. Retighten the retaining set screw. Open and close the pad roller to check for correct operation; make certain the roller flanges are not binding against the sprocket. Check the stop screw setting; allow a (2) film thickness clearance between the pad roller and the face of the sprocket.
4. To remove and replace the pad roller arm springs and balls, dismantle the pad roller assembly. Drive out the taper pin from the arm stud bushing and remove the bushing. Pull the stud and knob straight out of the arm casting and remove the springs and balls. Install the replacement springs and balls in position in the arm casting. Replace the stud and knob in the arm casting and add on the bushing stud. Press the stud and knob firmly against the arm and align the bushing with its tapered hole in the stud. Insert and secure the taper pin. Return the pad roller assembly to the film compartment and reset the (2) film thickness clearance between the pad roller and the sprocket face.

FIRE SHUTTER SETTING (Optional Accessory C1-G-22)

1. To reset the height of the (optional) fire shutter, open the gear compartment door and loosen the set screw in the upper governor weight holder. See Assembly C1-G-22 on the "Vertical Shaft" drawing following. Loosening the set screw will allow both the governor and the fire shutter to be raised or lowered as a unit.
2. Set to the correct height. If the shutter is too low, it will intrude into the light beam; if too high, it will strike the inner surface of the film compartment light shield.
3. When the proper height of the fire shutter has been set, tighten the upper governor weight set screw. Close the gear compartment door.

SHUTTER SHAFT REMOVAL

1. Remove the rounded portion of the shutter guard. Open the gear compartment.
2. Remove the (2) slotted screws retaining BR-0186 and the (4) socket screws mounting BR-0014. Remove the shutter shaft assembly as a unit.

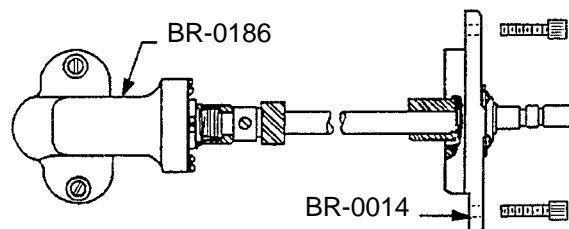

ADJUSTMENTS & REPLACEMENTS (continued)

VERTICAL SHAFT REMOVAL & SERVICING

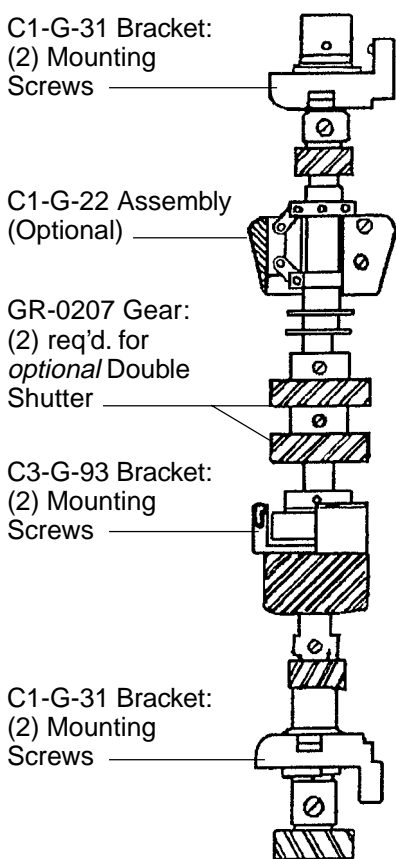

1. Remove the rounded portion of the shutter guard, open the gear compartment, and dismount the shutter shaft assembly.
2. Dismount the lower drive cover. Remove the (4) screws holding the (2) C1-G-31 ball bearing brackets (upper and lower; see illustration).
3. Remove the (2) socket head screws connecting the intermittent drive gear bracket (ref. C3-G-93) to the shutter adjustment bracket. Release the drive gear bracket from its position.
4. Using both hands, grasp the upper and lower bearing brackets (C1-G-31) and remove the entire vertical shaft assembly from the gear compartment.
5. To disassemble the vertical shaft, remove the collar nut on the top of the shaft by loosening its (2) set screws and unscrewing it from the shaft. Dismount the bottom gear from the shaft by removing its retaining screw.
NOTICE: Keep all components in sequence for reassembly. Steel washers are always placed against the face of all ball bearings.
6. Upon reassembly, the upper collar nut should be threaded down on the shaft to rest gently against the upper washer retainer. This will take out all end play between the ball bearings and the collar. When so positioned, tighten the (2) collar set screws.
7. To return the vertical shaft assembly to the mechanism, perform the above procedures 1 - 4 in reverse order. Before tightening down any mounting screws, make certain all gears mesh with a minimum of backlash, yet free of drag.
8. Reset the shutter timing before replacing the shutter guard. Refer to the instructions in the following section.

SHUTTER TIMING

1. Remove the rounded portion of the shutter guard. Remove the sight box glass from the operator's side by lightly pressing on the glass and sliding it upwards. With the glass removed, the indicator bar is visible in the sight box.
2. Rotate the shutter adjustment knob (if so equipped) to its center position. This knob exists on early model projectors only.
3. Rotate the motor flywheel to "inch" the mechanism. With the intermittent movement at rest (locked stage), position a stationary object next to a single tooth on the intermittent sprocket. Slowly rotate the flywheel and allow a (2) tooth advance.
4. Loosen the (2) screws in the hub of the shutter blade. Hold the intermittent flywheel in a stationary position to prevent the mechanism from moving, and rotate the shutter blade to the fully CLOSED position. A notch in the edge of the master shutter blade will align with the indicator bar in the sight box when the shutter is fully closed.

ADJUSTMENTS & REPLACEMENTS (continued)

SHUTTER TIMING (continued)

5. Firmly tighten the (2) screws in the hub of the shutter. Recheck the shutter timing by rotating the motor flywheel for another (2) tooth intermittent sprocket advance and verifying the alignment of the shutter notch to the indicator bar.
6. Replace the sight box glass and the shutter guard.

MAIN (HORIZONTAL) DRIVE SHAFT

1. Open the film compartment. Remove the ball bearing retainer below the lower sprocket by loosening the set screw to the right of the retainer. The ball bearing retainer has an 8-32 hole threaded in its center. By threading an 8-32 screw into this hole, the head of the screw can be used to pull the retainer straight out of the main frame.
2. Remove the (2) 1/4-20 set screws from the drive gear. The set screws are 90° apart.
3. Remove the (2) screws holding the seal on the gear side.
4. From the film compartment, using a brass bar and a hammer, tap the horizontal shaft until it works free. Withdraw it from the gear compartment side, leaving the drive gear in place.
5. Remove the drive gear from the grease bath.
6. To install a replacement drive shaft, first position the drive gear in the grease bath. Observe the position of the (2) set screws.
7. Slide the shaft through the outboard bearing and into the gear. Align the (2) holes in the shaft (90° apart) with the (2) set screws in the gear.
8. When the gear set screws are aligned to the holes in the drive shaft, slide the shaft into the inboard bearing. Tighten the (2) 1/4-20 set screws. The points of the set screws will engage the holes in the drive shaft when correctly aligned. Replace the (2) screws against the seal.
9. Seat the ball bearing retainer on the film compartment side to remove any end play. When seated firmly, tighten the retainer set screw.
10. Check the condition of the grease in the grease bath. If the grease is discolored or contaminated with dirt or dust, clean it out and replace with fresh TU-0380 Century Gear Lubricant. Grease the inner surfaces of the gear teeth.

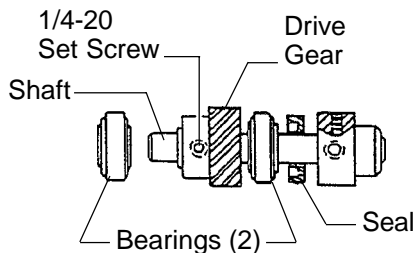

FRAMING LAMP REPLACEMENT

1. Unscrew the glass protector shield and remove the bulb from its socket.
2. Replace the bulb with a 12 volt, 6 watt candelabra-base bulb (Century Part No. LP-0122). Replace the glass protector shield over the bulb.

AUTOMATIC LENS TURRET

1. Check for correct contact between the turret drive tire and the driven indexing plate. Clean surfaces to prevent dust and dirt build-up; replace O-ring tire(s) if cracked or worn. *Do not lubricate.*

ADJUSTMENTS & REPLACEMENTS (continued)

LENS TURRET (continued)

2. Periodically check the (2) coil expansion springs on the index stop pin. Replace with new, matched pair if stretched or worn.

LENS POSITIONING

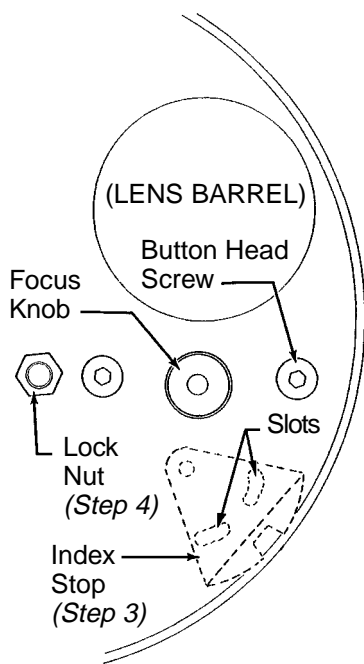

3. The index stops are mounted to the back surface of the lens indexing plate with (3) socket head screws. Two of the screw holes are slotted to permit fine adjustment of the lens position. Adjust the up-and-down position of the picture on the screen by loosening the (3) mounting screws and turning the slot-headed eccentric stud. When correct, securely tighten the (3) socket head mounting screws.
4. Left-to-right (horizontal) positioning of the picture on the screen is adjusted by loosening the (2) large stainless steel button head socket screws on each side of the focus knob (front surface of the indexing plate). When slightly loosened, rotate the large lock nut using a 1/2 inch wrench. This moves the eccentric adjustment. Securely tighten the (2) button head screws when the picture is correctly positioned.
NOTE: The adjustments outlined in Steps 3 and 4 are best performed using SMPTE RP-40 Test Film.
5. A screw in the center of the turret catch acts as a deadstop for turret closure. Adjustment of this screw is to be used to remove "play" ONLY; do not attempt to correct "keystoning" by use of this screw.
6. If a lens change fails to occur when cued, press the desired override switch (FLAT, SCOPE, or SPECIAL) on the turret control box. Check the condition of the cuing material; foil tape may be worn, or bar code information may be obscured by scratches or dirt. Check for faulty cue detector or failed contact in automation controller.
7. A malfunction in aperture/lens turret logic indicates a problem in the turret control board. *Consult the factory.* There are no user-serviceable components on the printed circuit board.
8. Periodically check the condition and positions of the magnets mounted to the index stops. These magnets are sensed by the proximity switch on the turret ring to determine aperture logic. A single magnet mounted *inboard* denotes FLAT, a single magnet on the *outboard* edge denotes SCOPE, and two magnets (*inboard* and *outboard*) indicate SPECIAL (TU2030C only). The magnets are to be positioned close enough to the proximity switch to permit accurate detection, but should not obstruct turret rotation.
9. Two L.E.D. indicators on the control cabinet display operation of the aperture-sensing proximity switch. When the upper L.E.D. is illuminated, the proximity switch is sensing the *inboard* magnet, and setting the FLAT aperture. The lower L.E.D. glows when the proximity switch senses the *outboard* magnet, and actuates the SCOPE aperture. Both L.E.D.'s glowing simultaneously indicates that the proximity switch senses two magnets, thereby setting the SPECIAL aperture (third lens, when used). Failure of the L.E.D. and/or failure of the aperture to cycle means that the magnets or the proximity switch are loose or out of alignment; adjust as required. Periodically clean the surfaces of the magnets to allow good conduction.

ADJUSTMENTS & REPLACEMENTS (continued)

INTERMITTENT MOVEMENT

Each Century Intermittent Movement utilizes components machined to near-zero tolerances and are assembled by trained technicians using special fixtures and tools. Many critical adjustments are difficult to perform in the field, and in some instances as noted, it is recommended to return the movement to the factory for overhaul by qualified personnel. Contact your authorized Strong International Dealer for Return Authorization and shipping information. Factory rebuilt intermittent movements are available under a Repair/Exchange program.

INTERMITTENT MOVEMENT REMOVAL

1. Open the gear compartment (off-operator side door) and dismount the intermittent flywheel.
2. In the film compartment, close the lower pad roller and frame the intermittent all the way DOWN. Dismount the gate pressure pad, the film trap, and the light shield.
3. Loosen, but do not remove, the (4) SC-0106 mounting screws. Rotate the intermittent movement clockwise approximately one-eighth (1/8) of a turn until the cutouts in the intermittent case align with the heads of the SC-0106 screws.
4. Pull the intermittent movement out of the film compartment, taking care not to strike the intermittent sprocket against any object which might damage its teeth.

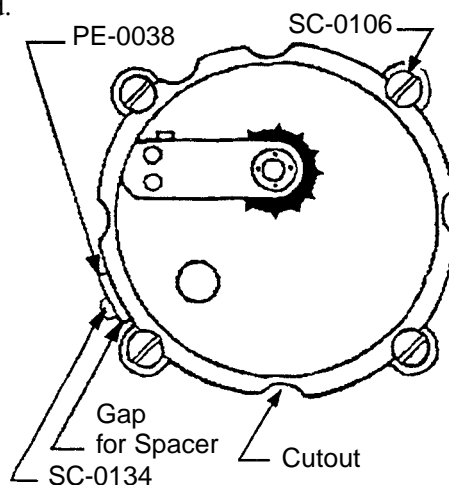

INTERMITTENT MOVEMENT INSTALLATION

1. Dismount the flywheel (if supplied) from the replacement movement. Loosen the SC-0134 intermittent stop screw.
2. Insert the intermittent movement into the film compartment. Align the cutouts in the intermittent case with the heads of the (4) SC-0106 mounting screws.
3. Slide the intermittent into its opening and rotate counterclockwise until the driven gear of the intermittent meshes with its drive gear on the vertical shaft. Turn the movement until the gears mesh with no backlash or excessive play.
4. Tighten any (2) of the SC-0106 mounting screws. Slide the PE-0038 stop plate firmly against its stop, and tighten the SC-0134 screw.
5. Loosen the (2) SC-0106 screws previously tightened. Rotate the movement clockwise to allow a 3/64" (1.19mm) gap between the stop plate and its stop.
6. Insert a 3/64" (.0468 inch; 1.19mm) spacer (i.e. a U.S. dime) between the stop plate and its stop. Tighten all (4) SC-0106 mounting screws. This allows the slight (.003 inch) degree of backlash required between the vertical shaft drive gear and the intermittent driven gear.
7. Loosen the SC-0134 stop plate screw and remove the above spacer. Press the PE-0038 stop plate against its stop and tighten the SC-0134 screw.
8. Lubricate the gears using TU-0380 Gear Lubricant. Install the intermittent flywheel. Fill the intermittent movement to the oil level line with Century Projector Oil. DO NOT OVERFILL.
9. TIME THE SHUTTER following the instructions preceding in the ADJUSTMENTS AND REPLACEMENTS section.

ADJUSTMENTS & REPLACEMENTS (continued)

INTERMITTENT SPROCKET REPLACEMENT

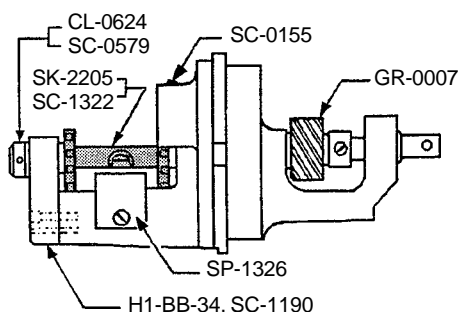

1. Remove the intermittent movement per preceding instructions. Rotate GR-0007 gear until the intermittent sprocket comes to its locked position.
2. Remove the SP-1326 film stripper and the SC-1322 screw holding the SK-2205 intermittent sprocket to its shaft.
3. Loosen the (2) SC-0579 set screws in the CL-0624 collar, and remove the collar.
4. Remove the (2) SC-1190 socket head screws mounting the H1-BB-34 outboard bearing arm. Remove the bearing arm.

NOTE: The outboard bearing arm (H1-BB-34) is factory-positioned by (2) dowel pins. If the bearing arm does not slide off freely, tap gently on the inner side of the arm, taking care not to bend the starwheel shaft.

5. Slide the SK-2205 sprocket off the starwheel shaft. Slide the replacement sprocket onto the shaft without applying force.
6. Align the mounting hole in the sprocket to the hole in the starwheel shaft. Insert the SC-1322 screw and add the nut; do not tighten.
7. Replace the H1-BB-34 outboard bearing arm, aligning to the dowel pins. Secure with the (2) SC-1190 socket head screws.
8. Thread the sprocket clamping nut onto the SC-1322 screw until two sides of the hexagon seat in the cutouts on the sprocket hub. This will anchor the nut for tightening.
9. Replace the CL-0624 collar on the end of the starwheel shaft. Press the collar against the outer surface of the starwheel bushing, while pulling the sprocket toward the collar. When the end play has been thus removed, tighten the (2) SC-0579 collar set screws. Replace the SP-1326 film stripper.
10. Replace the intermittent movement. Set backlash as instructed above. Align the intermittent sprocket to the film trap and securely tighten the SC-1322 sprocket retaining screw.
11. Replace the intermittent flywheel. TIME THE SHUTTER.

INTERMITTENT SPROCKET SHOE ASSEMBLY

1. Open the intermittent shoe assembly. Loosen, but do not remove, set screw SC-0155 in the intermittent case.
2. Pull the intermittent shoe assembly out of the film compartment.
3. When replacing, align the detent in the shoe assembly stud with the SC-0155 set screw. Tighten SC-0155 gradually to allow the point of the set screw to locate the center of the detent.
4. The knurled adjusting nut permits fine adjustment of shoe tension.

INTERMITTENT CAMSHAFT END PLAY ADJUSTMENT

NOTE: This adjustment is best performed at the factory by trained personnel.

1. Remove the large plug screw in the center of the intermittent cover to expose the end of the thrust bearing.

ADJUSTMENTS & REPLACEMENTS (continued)

INTERMITTENT CAMSHAFT END PLAY ADJUSTMENT (continued)

2. The bearing may be tightened or loosened by means of the screwdriver slot. It should be adjusted so that there is no perceptible end play in the camshaft, yet not tight enough to cause the camshaft to drag.

INTERMITTENT STARWHEEL AND CAMSHAFT SPACING

NOTE: This adjustment is best performed at the factory by trained personnel.

1. Dismount the intermittent sprocket shoe assembly. Slightly loosen the (4) socket head intermittent cover retaining screws (SC-1047).
2. The (2) small slot head set screws (SC-0039) at the rim of the intermittent cover in front of the intermittent shoe assembly alter the relative positions of the intermittent cover and case. This position is set at the factory, and in normal operation should *not* be readjusted.
3. The starwheel shaft mounts to the cover, and the camshaft mounts to the case. Alternately loosening and tightening the (2) SC-0039 screws shifts the position of the intermittent cover, thereby changing the spacing between the star and cam. If adjusted incorrectly, the intermittent movement may become noisy, or alternately, run too tight for normal operation. Misadjustment may contribute to premature failure of the movement.
4. **DO NOT PERFORM THIS ADJUSTMENT IF THE PROJECTOR IS UNDER WARRANTY. INTERMITTENT DAMAGE CAUSED BY FAULTY FIELD ADJUSTMENT IS NOT COVERED BY WARRANTY. Consult factory before attempting field adjustment.**

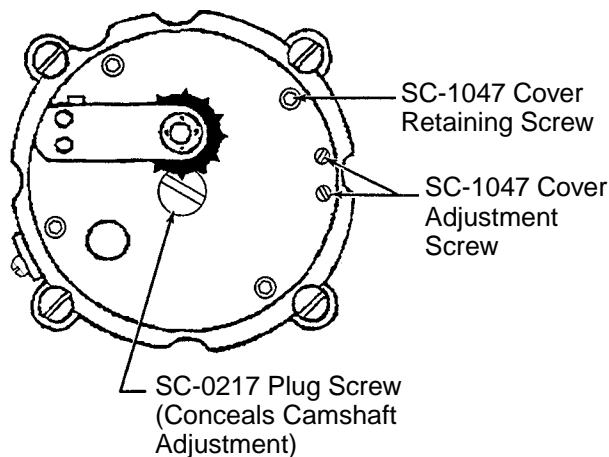

SUPPLEMENTAL PARTS LIST
TU2020C & TU2030C TURRET
for Century Projector

THE FOLLOWING PAGES include a listing of parts unique to the TU2020C and TU2030C Turrets as used on the Century Turret Projector. This turret was adopted for use on Century Projectors by Strong International in March 1997.

PARTS NOT LISTED in the following section will be shown in the 35mm TURRET PROJECTOR PARTS LIST book which is supplied with each Century Turret Projector. The PARTS LIST book includes pages detailing the TA Turret formerly manufactured by Strong, and these pages remain for the convenience of users of the older turret. The Film Gate and Film Trap/Aperture Changer as shown in the PARTS LIST book remain unchanged in the TU2020C configuration.

WITH THE EXCEPTION of the Indexing Plate (see the Turret Parts Drawing, Items 5 & 6) and a Locking Screw (Item 12), the TU2020C and the TU2030C use the same mechanical parts. Turret Controllers utilize one of two IC chips (two-lens or three-lens logic), and the placement of jumpers differ. The Controller PCB is generally *not user serviceable*.

REPLACEMENT PARTS are available only through authorized Strong International Dealers. Specify Equipment Type and Serial Number when ordering parts.

ALL RETURN ITEMS shipped to Strong International must display a **Return Authorization Number** issued prior to such shipment. R.A. Numbers must be requested through Strong International Dealers, and all freight must be prepaid.

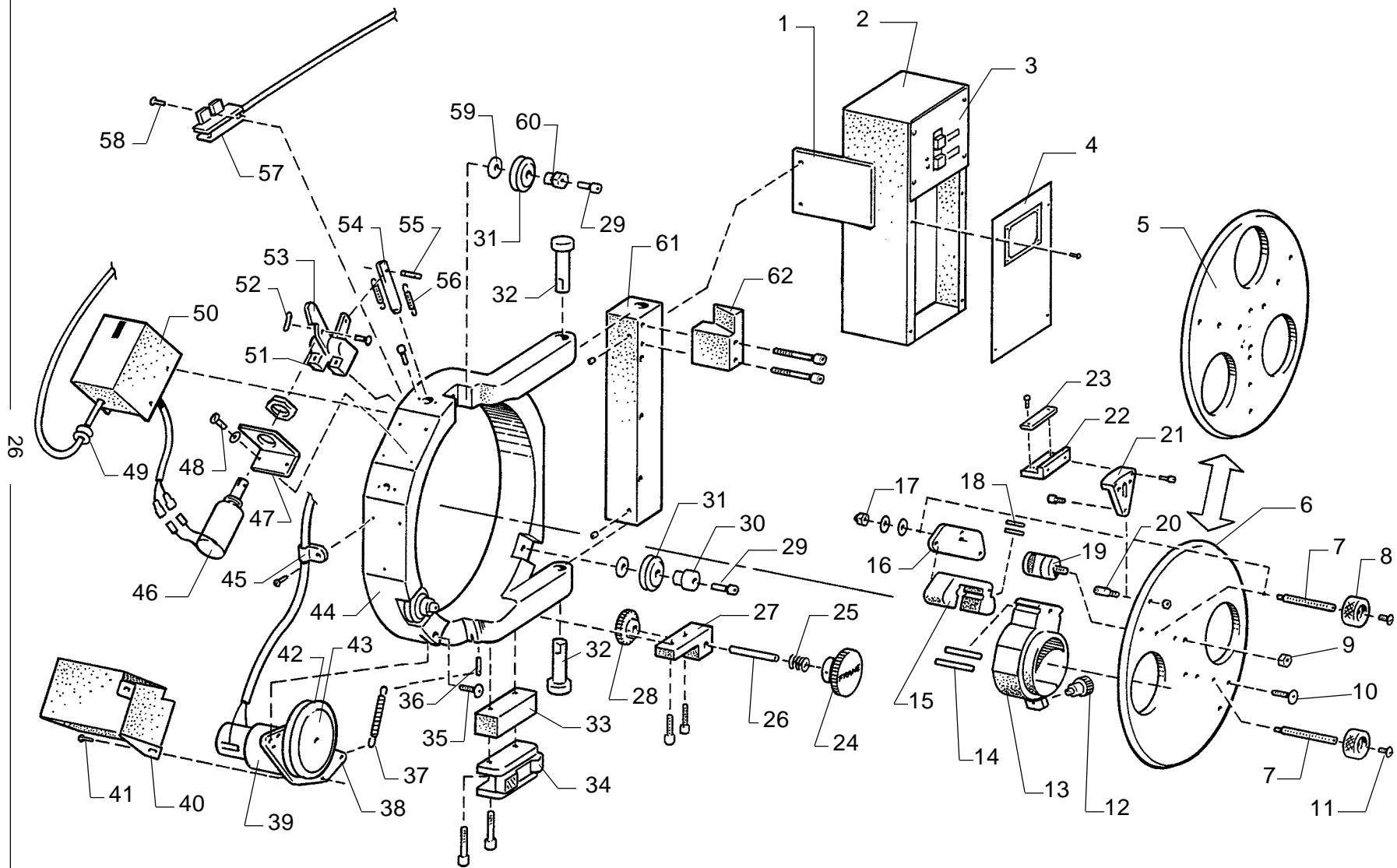

CENTURY LENS TURRET TU2020C, TU2030C
 DC Motor & Solenoid, January 1998

CENTURY LENS TURRET

Parts List

<u>Item</u>	<u>Part No.</u>	<u>Description</u>
1	10253	Mounting Plate, Control Cabinet
2	P-10093	Control Cabinet (less Components)
3	P-10092	Upper Cover, Control Cabinet (as shown; Two-Lens)
-	P-10149	Upper Cover, Control Cabinet (Three-Lens)
-	52-70081	Control PC Board Assembly, Two-Lens, 115/230 V.AC
-	52-70091	Control PC Board Assembly, Three-Lens, 115/230 V.AC
-	51-61006	Switch, Lens Re-Set (with Printed Circuit Board)
4	P-10091	Lower Cover Panel, Control Cabinet
-	P-10121	Transformer (T2), not shown
-	52-70077	Power Distribution PC Board (not shown)
5	P-7776	Indexing Plate, Three-Lens
6	P-7847	Indexing Plate, Two-Lens
7	P-7764	Lens Focus Screw
8	22-21126	Knob, Lens Focus Screw
9	01405A	NyLock Hexnut, 5/16-24
10	41-51429	Screw, 5/16-24 x 3/4" Button Head, Stainless Steel
11	41-51097	Screw, 10-32 x 3/8" Pan Head
12	21-28022	Knob, Lens Locking Screw
-	P-7905	Lens Locking Screw (Two-Lens)
-	41-51269	Lens Locking Screw (Three-Lens)
13	P-7779	Lens Barrel Casting
14	P-7772	Slide Rod, Lens Barrel (2 req'd)
15	P-7778	Base Mount, Lens Barrel
16	P-7780	Back Plate, Lens Base
17	41-35006	Lock Nut, Focus Screw; 6-32 Acorn
-	21-70028	Wave Spring Washer, #6
-	01553	Flat Washer, #6 Stainless Steel
18	41-51182	Set Screw, 10-32 x 5/8" (2 req'd.)
-	H-3218	Lock Nut, 10-32 Hex (2 req'd.)
19	P-7775	Adjusting Screw, Eccentric (Horizontal)
20	P-7789	Adjusting Screw, Eccentric (Vertical)
21	P-7790	Index Stop Bracket
-	41-51564	Mounting Screw, 10-32 x 1/2" Socket Head, Stainless Steel (3 req'd.)
22	P-10119	Magnet Mounting Bracket
23	P-10122	Magnet (2 req'd. with Three-Lens)
24	KN-0044	Framing Knob
-	41-51365	Knob Mounting Screw, 10-32 x 3/8" Socket Head
25	P-6943	Compression Spring

TURRET PARTS LIST (continued)

<u>Item</u>	<u>Part No.</u>	<u>Description</u>
26	10250	Framing Knob Shaft, Turret Mount
-	10260	Framing Shaft (not shown, Projector mounted)
<i>10260 replaces ST-0001 as shown in Parts List booklet, "C1-A-21 Assembly"</i>		
27	10251	Mounting Block, Framing Knob Shaft
-	41-51578	Block Mounting Screw, 1/4-20 x 1" Socket Head, Stainless Steel
28	10341	Coupling Gear, Framing Knob Shaft; 18 Tooth
-	10342	Coupling Gear, Framing Shaft; 48 Tooth (not shown, Projector mounted)
29	41-51228	Screw, 5/16-18 x 3/4" Socket Head, Stainless Steel (3 req'd.)
30	51-07012	Straight Bushing, Lower (2) Bearings <i>See Item 60 for Adjustable Bushing (Top Position only)</i>
31	51-49010	Ball Bearing, Indexing Plate (3 req'd.)
-	41-70023	Flat Washer, 1/4" (ref. Item 59; 3 req'd.)
32	P-7765	Hinge Pin (2 req'd.)
-	41-51186	Set Screw, Hinge Pin Retaining; 1/4-20 x 3/8" (2 req'd.)
33	10261	Spacer Block, Turret Latch
34	G-7980	Turret Latch Assembly
-	P-7770	Latch
-	21-37038	Stop Pin
-	21-58038	Compression Spring
-	P-7779	Base Plate
-	51-51011	Pivot Bolt
-	41-51264	Mounting Screw, 10-32 x 1-1/2" Socket Head (2 req'd.)
35	51-51011	Shoulder Screw, Motor Mount Pivot
36	52-20623	Spring Retaining Screw
37	P-3045	Expansion Spring
38	P-10115	Motor Mounting Plate
39	51-33030	Drive Motor, 12 V.DC
40	P-10148	Motor Cover
41	41-51032	Cover Mounting Screw, 6-32 x 1/4" Pan Head (2 req'd.)
42	21-48001	O-Ring Drive Tire (2 req'd.)
43	P-7794	Drive Wheel, Indexing Plate
44	P-7777	Turret Ring Casting
45	P-4393	Cable Clamp, Nylon
-	41-51032	Screw, 6-32 x 1/4" Pan Head
-	P-10104	Wire Harness, Motor & Solenoid
46	P-10116	Solenoid (including Nut & Lockwasher)
47	P-10124	Solenoid Mounting Bracket
48	41-51567	Bracket Mounting Screw, 10-32 x 3/8" Socket Head (2 req'd.)
49	41-98002	Grommet

TURRET PARTS LIST (continued)

<u>Item</u>	<u>Part No.</u>	<u>Description</u>
50	P-10117	Solenoid Cover, Welded Assembly
-	41-51032	Cover Mounting Screw, 6-32 x 1/4" Pan Head
51	P-10118	Mounting Block, Reset Lever
52	01704	Hitch Pin, 1/16" Diameter
-	P-7966	Clevis Pin, 1/8" Diameter
53	P-7785	Pin Reset Lever
54	P-7784	Index Stop Pin
55	P-7787	Spring Tension Shaft, Grooved
56	P-7786	Expansion Spring (2 req'd.)
57	52-70078	Proximity Switch Wired Assembly, Aperture Sensor
-	G-7831	Cover, Proximity Switch
-	41-51032	Cover Mounting Screw, 6-32 x 1/4" Pan Head
58	41-51032	Switch Mounting Screw, 6-32 x 1/4" Pan Head
59	41-70023	Flat Washer, 1/4" (3 req'd.)
60	51-07013	Eccentric Bushing (Top Bearing only)
61	10249	Mounting Bar, Century Turret
-	41-51580	Bar Mounting Screw, 1/4-20 x 1-3/4" Socket Head, Stainless Steel
62	82-20422	Limit Block, Turret "Open"
-	41-51581	Block Mounting Screw, 1/4-20 x 2" Socket Head, Stainless Steel

ASSOCIATED PARTS (Not Shown)

P-7774	Turret Catch (mounts to 10252 Bracket; mates with Item 34 Latch)
41-35024	Catch Lock Nut, 1/2-20 Hex
41-51531	Turret Deadstop Screw, 1/4-20 x 2" Headless
41-35016	Lock Nut, Deadstop Screw; 1/4-20 Hex
10252	Mounting Bracket, Turret Catch (mounts to Projector Main Frame)
41-51223	Bracket Mounting Screw, 1/4-20 x 1" Socket Head (4 req'd.)
10259	Projector Main Frame (machined for Type "TU" Turret)
	<i>10259 replaces FR-0070T Main Frame shown in Parts List booklet</i>

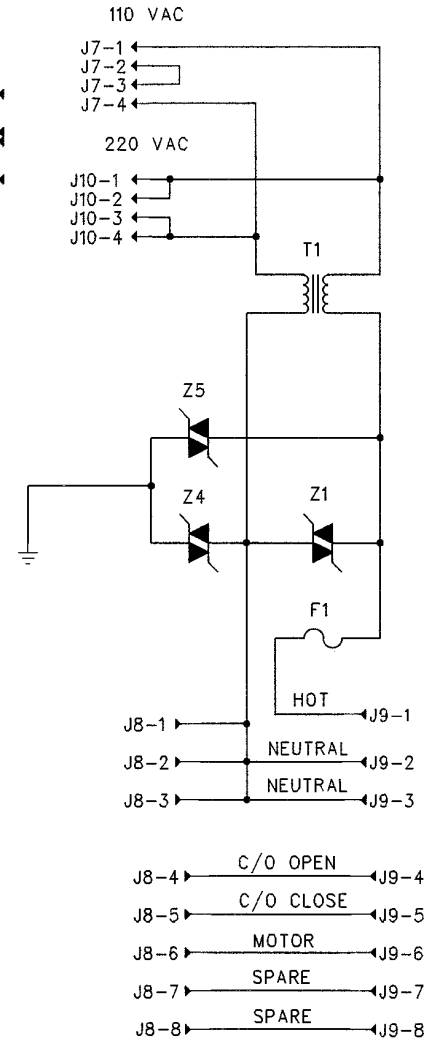
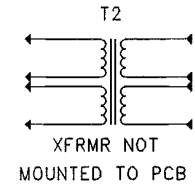
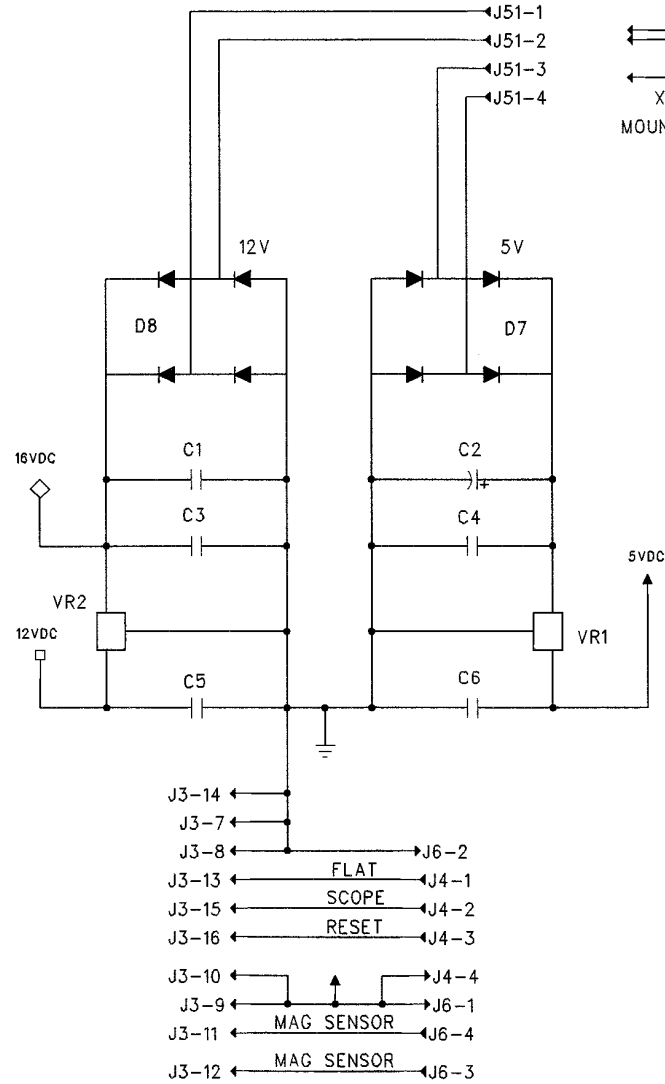
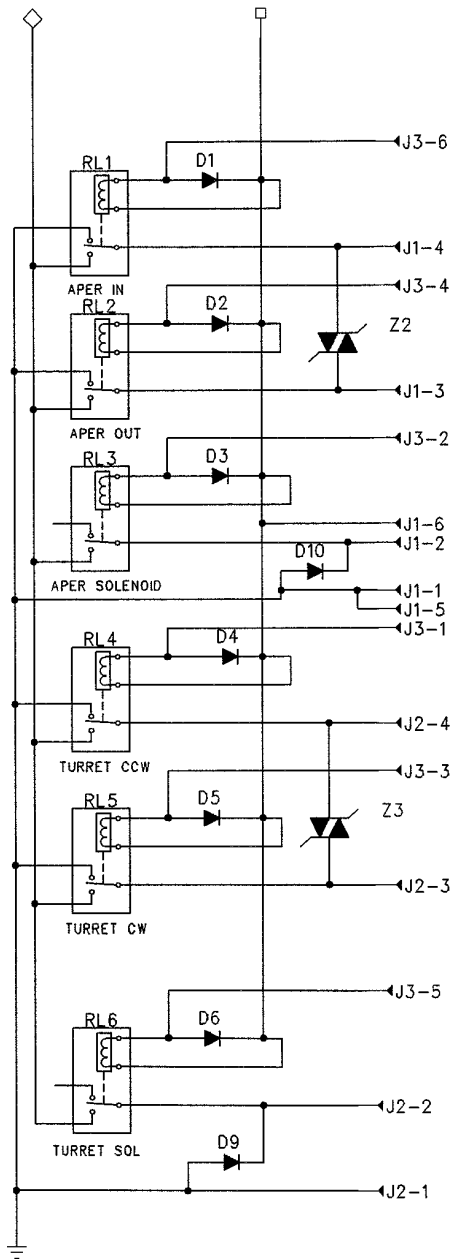

CONTROL CABINET, Wiring Diagram

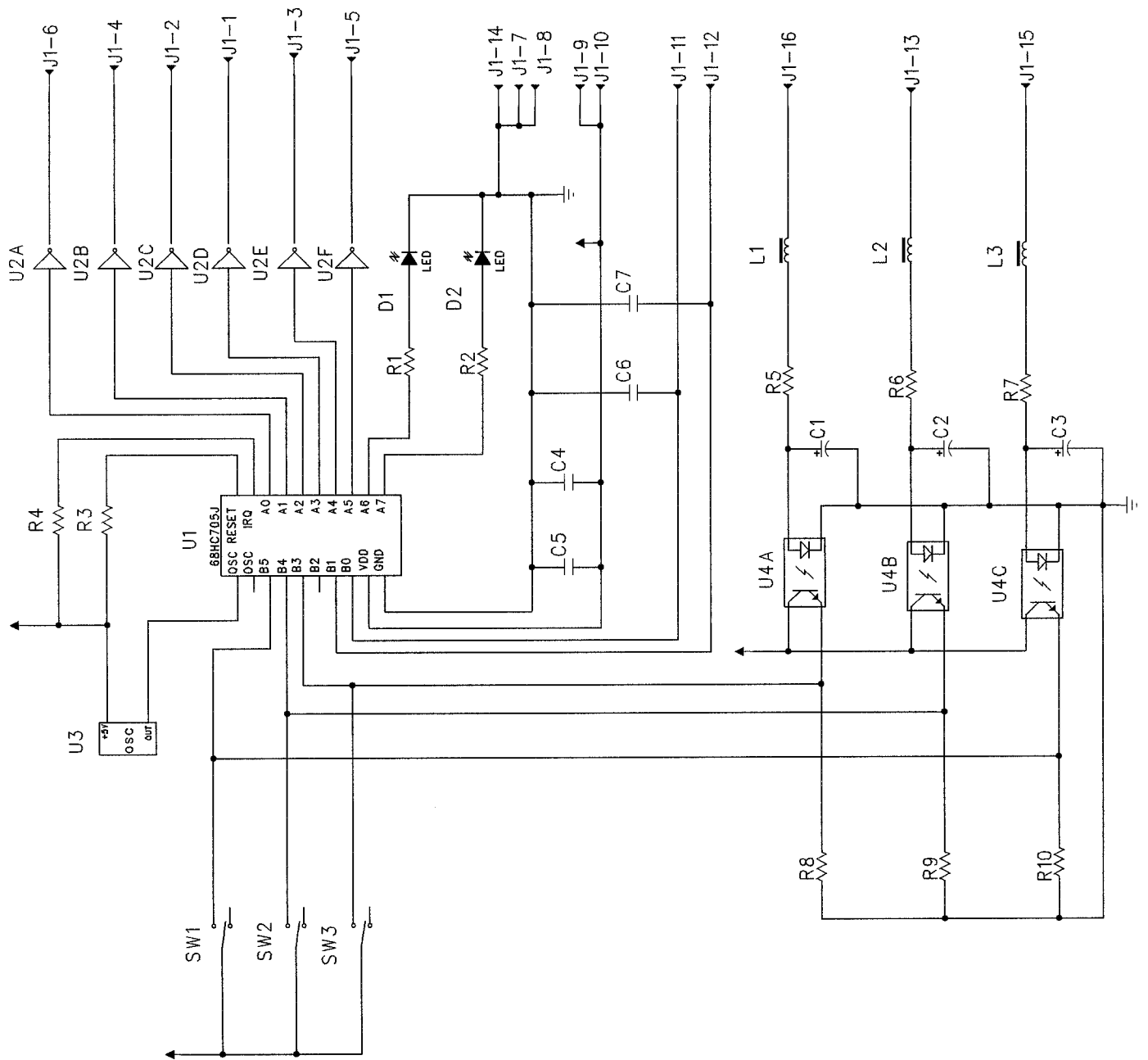

TURRET CONTROL PRINTED CIRCUIT BOARD
Wiring Diagram

