

PREFACE

THE STRONG HIGHLIGHT II Xenon Projection Console is designed and manufactured by Strong International for use in professional cinema presentation. The Console lamphouse incorporates an interference-coated deep ellipse nickel reflector designed to operate at 33-1/8" from the film plane, and utilizes a horizontal xenon bulb as the light source.

LAMPHOUSE INSTRUMENTATION includes a DC ammeter to indicate the operating current of the bulb, and an elapsed time meter to record hours of bulb use. The rocker switch below the analog ammeter changes the meter reading to display the DC voltage at the arc. Indicator lights are provided on analog control models to show that AC power is energized, air flow is adequate, doors are secured, and bulb is ON. A digital LCD screen is a standard-cost option, and provides a continuous display of current, voltage, wattage, and elapsed hours.

A SIMPLIFIED CONTROL CIRCUIT ignites the xenon bulb using a DC Pulse Igniter Assembly. The igniter operates when provided high DC open circuit voltage normally developed by the xenon power supply at start-up, and requires no AC inputs.

SERVICE AND MAINTENANCE are accommodated by hinged access doors. Key locks assure access to authorized personnel only. Interlock switches at the rear and both lamphouse access doors disable operation of the xenon bulb if these doors are opened during lamphouse operation.

AIR FLOW INTERLOCK SWITCHES, installed at the lamphouse upper blower inlet and at the base of the exhaust duct, will prevent bulb ignition if the blowers are not operating. The switches will also interrupt operation of the bulb if air flow falls to an inadequate cooling level.

ADJUSTMENT CONTROLS to position the xenon bulb in relation to the reflector are located on the back of the bulb enclosure. A small access door is incorporated in the rear access door to permit manipulation of the bulb adjustment controls while the lamp is operating. The body of the control mechanism allows horizontal and vertical movement of the bulb, and rotation of the threaded center section adjusts bulb focus. Lock screws secure the mechanism when the bulb is correctly positioned.

A MANUALLY OPERATED DOUSER permits shutting off the light to the projector. The douser is normally left in the OPEN position when the lamp is used in conjunction with an automation system. To prevent deterioration of the douser plate, do not operate the lamphouse for a prolonged period with the douser closed. Do not, under any circumstances, operate the lamphouse in excess of (25) minutes with the douser closed. Observe the HIGH TEMPERATURE warning on the lamphouse snood adjacent to the douser handle. Surface temperatures may reach hazardous levels when the bulb is operating.

SUPPORT EQUIPMENT not supplied by Strong International (automation, amplifiers, sound processors, etc.) must be UL Listed, and is provided by the customer. This equipment is factory installed and pre-wired if so ordered by the customer. See the manuals supplied by the manufacturers of this equipment for information on operation and service.

Highlight II Console

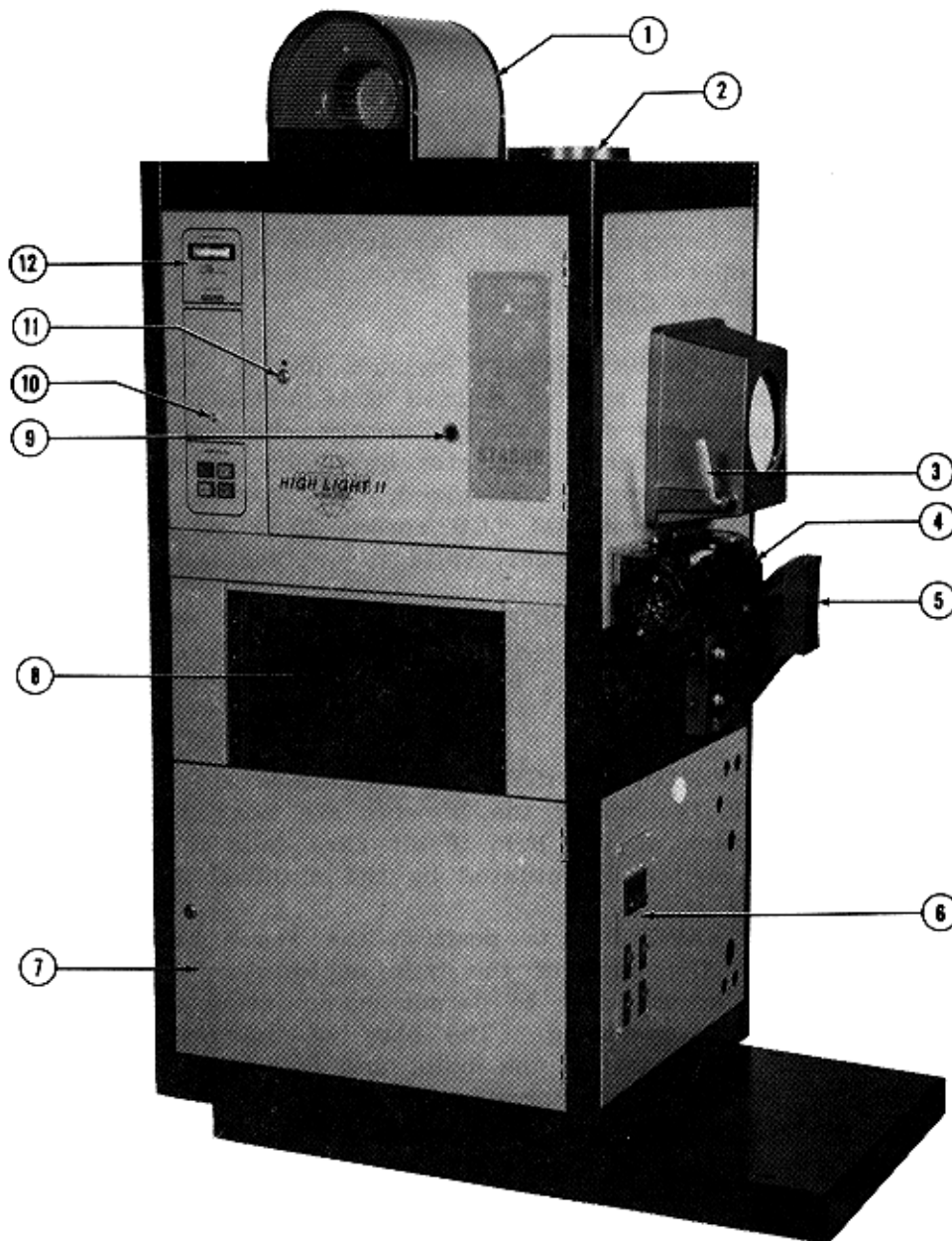

- | | |
|---------------------------------|---|
| 1. Top Intake Blower | 8. Accessory Rack, 19 inch Centers |
| 2. Exhaust Stack, 8 inch | 9. Arc Viewing Port |
| 3. Douser Handle | 10. Current Adjust Potentiometer
(Switching Power Supply only) |
| 4. Front Intake Blower | 11. Key Lock, Lamphouse Access Door |
| 5. Soundhead Mounting Arm | 12. Lamphouse Instrument Panel
(See Figure 2 for Details) |
| 6. Distribution Panel, AC Power | |
| 7. Power Supply Access Door | |
- Leveling Feet (not shown) Packed with Accessory Kit

Run Halftone Plate HL2/002

RECEIVING & INSTALLATION

INSPECT THE SHIPMENT immediately and report any damage to the freight carrier. It is the responsibility of the consignee, not the shipper, to press damage claims. Strong International will provide shipping documents upon request.

MOVE THE CONSOLE on its base pallet as far as possible to its intended location. After removing the console from the pallet, install the four leveling pads and level the console to the booth floor. NOTE: If the booth floor is a soft material, such as linoleum, it is advisable to obtain four 4 inch x 4 inch x 1/4 inch steel plates to place under the leveling pads to prevent "settling."

THE LEVELING FEET on the console are adjustable by loosening the locknut and raising or lowering the corner by turning the stud of the leveling foot with an end wrench. Retighten the locknut after leveling the console.

EACH CONSOLE is supplied with a soundhead spacer block to correctly position the projector aperture at the specified 33-1/8 inch (84.15cm) working distance from the center of the lamphouse reflector. The make and model of the soundhead and projector must be specified with the original equipment order to enable Strong International to supply the correct spacer block. The correct mounting hardware is supplied with the spacer block.

<u>PROJECTOR - SOUNDHEAD MANUFACTURER</u>	<u>SPACER BLOCK PART NO.</u>
Ballantyne	71229
Simplex	71231
Century	71231
RCA 9030	71924
Cinemeccanica V5	71722
Cinemeccanica V8	23809

USING THE CORRECT SPACER BLOCK and the soundhead mounting bolts provided, mount the soundhead to the projector mounting arm on the front of the console. This is most easily accomplished by starting the top two bolts, through the washers and spacer block, into the back of the soundhead casting. The soundhead can then be lifted into place, and the top two bolts into the soundhead casting lowered into the slotted holes in the projector mounting arm. In this manner, the mounting arm will bear the weight of the soundhead while the two bottom bolts are started.

TO AVOID CROSSTHREADING, the soundhead mounting bolts should be screwed in fingertight as far as possible. Before tightening the bolts, check first the console, and then the projector mounting surface, for level.

RECEIVING & INSTALLATION (continued)

MOUNT AND ALIGN the projector in accordance with the manufacturer's instructions. The 115 V.AC supply to the framing light, or the framing light transformer, may be derived from either the convenience outlet or any of the 115 V.AC terminals on the main terminal board.

THE FAN PANEL, located near the bottom of the off-operator side door, is equipped with two six-inch (15.2cm) blowers for cooling a high reactance xenon power supply (when used). Check the molded plug electrical connections for good contact; vibration from shipping and handling may loosen these connections.

CORRECT INSTALLATION of the desired xenon bulb in the Highlight II is determined by the size of the cathode support collet installed in the lamphouse. The collet installed is determined by the bulb model and type specified on the original equipment order. Open the lamphouse access door, remove the stainless steel bulb compartment cover, and examine the cathode support collet. Notify your Strong International Dealer if the collet is not appropriate to your desired xenon bulb.

<u>Bulb</u> <u>Wattage</u>	<u>Collet</u> <u>Part No.</u>	<u>Overall</u> <u>Length</u>	<u>Socket</u> <u>Diameter</u>
2000 & below	24179	5-3/8" (13.65cm)	.475" (12mm)
2000, 3000 "HS"	24201	5-5/16" (13.50cm)	.312" (8mm)
2500 "HS"	24201	5-5/16" (13.50cm)	.312" (8mm)
3000	24180	4-3/8" (11.11cm)	.551" (14mm)
4000-4500 "HS"	24181	4-1/4" (10.80cm)	.312" (8mm)
5000	24433*	4-5/8" (11.75cm)	.710" (18mm)
7000 "HS"	24181	4-1/4" (10.80cm)	.312" (8mm)
3000-7000 "H/VC"	24180	4-3/8" (11.11cm)	.551" (14mm)

* Osram XBO5000W/H OFR; other types, consult Factory

EXHAUST SYSTEM INSTALLATION:

THE EXHAUST STACK of the console lamphouse is designed to fit an eight inch (200mm) diameter duct. This size ducting must be used throughout the entire system and installed to eliminate any possibility of downdraft or rain dripping into the lamphouse. The exhaust blower must be capable of removing 300 cubic feet (8.5 cubic meters) of air per minute, as measured at the exhaust stack. Install bypasses rather than dampers if it is necessary to restrict the air flow.

IF MORE THAN ONE CONSOLE is installed in a common projection booth, the exhaust air flow must be measured at each individual console. Inadequate exhaust draft contributes to premature xenon bulb failure.

IF REPLACING a carbon arc lamphouse, make certain that the entire exhaust system is thoroughly clean of all carbon ash or residue. Carbon residue falling on a xenon bulb will burn into the quartz envelope and possibly shorten bulb life.

WIRING INSTALLATION

ALL INSTALLER CONNECTIONS to the Highlight II Console are made to the main terminal board located behind the left (off-operator) door and blower panel toward the front of the unit adjacent to the xenon power supply.

BECAUSE OF HIGH VOLTAGES impressed during the ignition cycle, the console *must* be grounded. Connect the ground wire to the grounding lug adjacent to the terminal board.

THE AC REQUIREMENT for the Highlight II is a four-wire three phase line (three phase plus neutral), with a separate earth ground. Voltage requirements are stamped onto the Name and Data Plate. All branch circuits are derived from this main input. The AC supply must be installed by a qualified electrician in conformance to local codes. Hardware, wire sizes and conduit types must comply with local codes. A readily accessible disconnect device shall be incorporated in the AC supply line to permit the operator to turn off all power to the console if required. Installer connections include three phase "hot" connections to Terminals 1, 2, and 3, and a neutral connection to Terminal 6. See the attached Installation Diagram.

AUTOMATION SWITCHING LEADS connect to the (2) terminal barrier strip adjacent to the AC input terminal board. *Do not apply voltage* to these terminals; a sustained dry contact rated at five amperes is required. The LAMP switch on the lamphouse control panel is provided for manual ignition control, and to act as an override in the event of an automation failure.

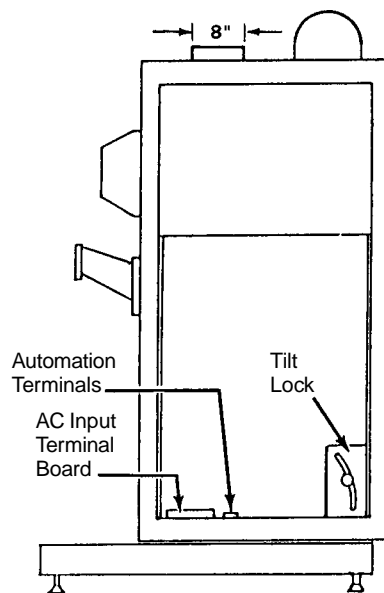

OPTICAL ALIGNMENT

THE OPTICAL SYSTEM of every Highlight II Console is laser aligned at the factory in the course of assembly and testing. This alignment procedure positions the reflector to best collect the light generated by the xenon arc and project it to the film plane. The *focal distance* is the space between the arc and the reflector (2.95 inches; 57mm), and is determined by the use of the correct bulb support collet. The *working distance* is the space between the picture aperture and center hole of the reflector ($33.125" \pm .25"$; $84.15\text{cm} \pm 6\text{mm}$), and is set by the installation of the correct soundhead spacer block. See the preceding RECEIVING & INSTALLATION section for bulb support collet and spacer block part numbers.

AN ALIGNING KIT (81906) is shipped with each console to enable field installation of a projector and soundhead, or to reset the factory adjustments if disturbed in the course of shipping. Before installing the Aligning Kit, open the lamphouse douser, clear the projector shutter blades, open the changeover douser, and tie the fire shutter (when used) open. Make certain the soundhead and projector mounting hardware is securely tightened.

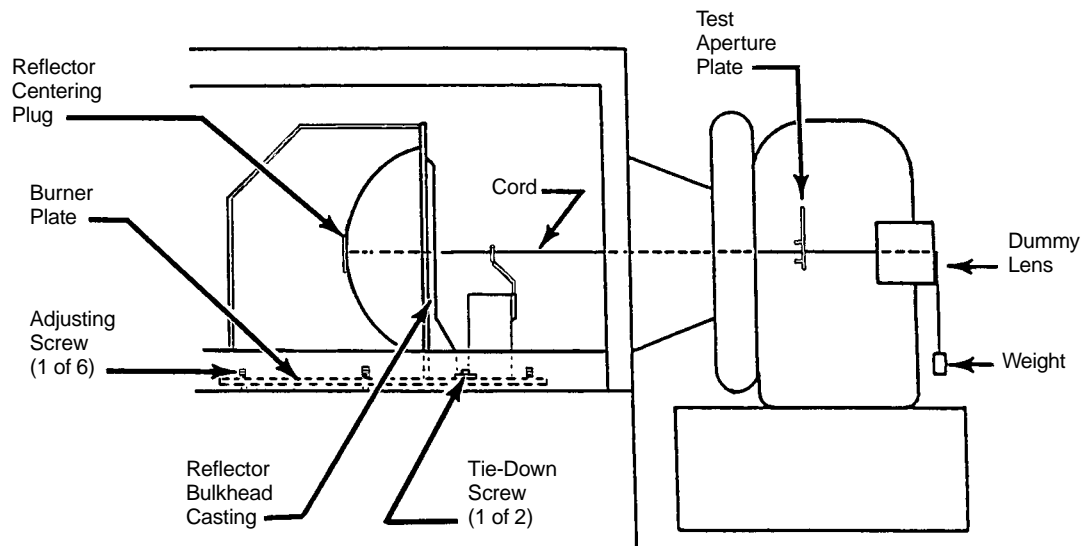

WORKING DISTANCE: 33.125" (84.15cm)

THE DRAWING ABOVE illustrates the placement of the Aligning Kit components. Tie the cord off behind the reflector centering plug. Run the cord through the lamphouse snood, into the projector, and through the film trap. Pass the cord through the hole in the dummy lens, and install the dummy lens into the lens barrel. Attach a weight to the end of the cord. The "weight" is supplied by the installer; use any object of adequate weight to hold the cord taut. Insert the tabs of the test aperture plate into the film trap. Close the projector gate to secure the test aperture plate.

OPTICAL ALIGNMENT (continued)

LOOK INTO THE REFLECTOR and locate the reflection of the aligning cord. When the reflector is correctly positioned, the actual cord will cover its own reflected image. If the reflected image is visibly offset from the cord, a degree of re-adjustment must be performed.

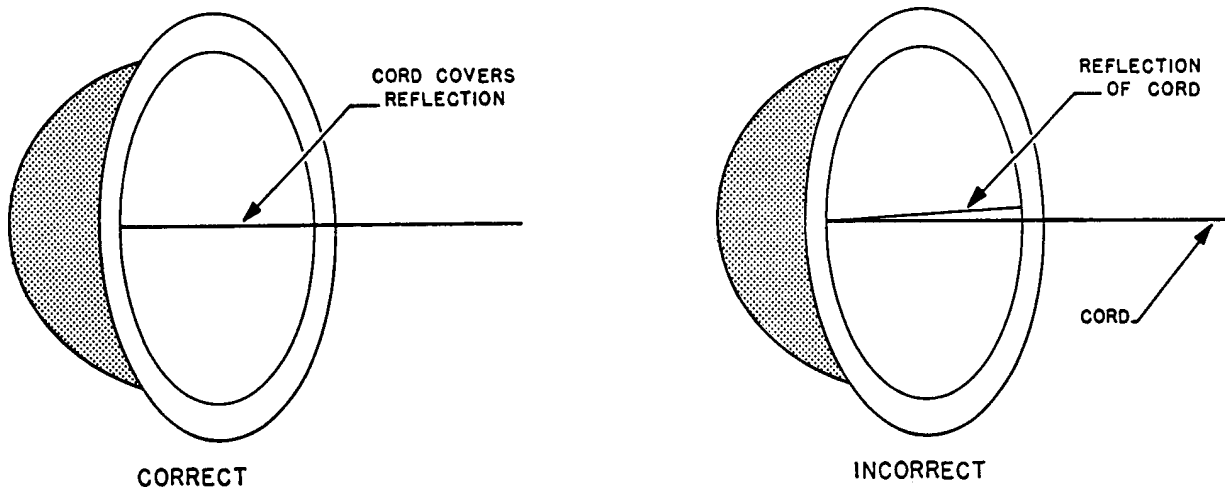

THE REFLECTOR BULKHEAD CASTING is fixed to the lamphouse burner plate and requires no adjustment. The entire burner plate may be adjusted by loosening the (2) socket head tie-down screws and shifting the burner plate on its base plate. Alternately tightening and loosening the (6) headless adjusting screws will raise or lower the front or back of the burner plate. Carefully observe the string image while adjusting the burner plate. When the “correct” (single-string) image is seen, and the cord remains in the center of the test aperture plate, secure the (2) tie-down screws, and tighten the (6) adjusting screw lock nuts.

A SLIGHT DEGREE OF ADJUSTMENT is available by repositioning the soundhead mounting arm. To adjust, loosen the (4) hex head mounting screws and alternately tighten or loosen the (6) headless set screws around the perimeter of the base of the casting. Re-tighten the (4) hex head screws upon completion of the adjustments.

REMOVE THE ALIGNING KIT COMPONENTS and restore operation of the projector fire shutter. Store the aligning kit parts in a secure location in the projection booth, as it may be necessary to again re-align the optical system if a replacement reflector is installed.

RE-CHECK THE WORKING DISTANCE ($33\text{-}1/8 \pm 1/4$ inch) after making any adjustment to the reflector. Operating the lamphouse at the incorrect working distance can produce poor screen illumination or damage film.

SAFETY PROCEDURES

THE XENON BULB is highly pressurized. When ignited, the normal operating temperature of the bulb increases the pressure to a level at which the bulb may explode if not handled in strict accordance to the manufacturer's operating instructions.

THE BULB is stable at room temperature, but may still explode if dropped or otherwise mishandled.

REFER bulb replacement and service to QUALIFIED PERSONNEL with adequate protective clothing (face shield, clean cotton gloves, welder's jacket). For routine lamphouse service, observe the following rules:

1. Allow the bulb to cool to room temperature before opening the lamphouse. Put on protective clothing described above.
2. De-energize the xenon power supply at the AC source before opening the lamphouse compartment.
3. When possible, encase the bulb in its protective cover when cleaning or servicing the lamphouse interior. The bulb, when outside the lamphouse, must be encased in the cover.
4. Clean the bulb after it has cooled to room temperature. Do not touch the quartz envelope of the bulb; fingerprints will burn in and create hot spots which may shorten bulb life. If fingermarks are made, they should be carefully removed with methyl alcohol and cotton prior to bulb operation.
5. Never view an ignited bulb directly. **BLINDNESS OR PERMANENT EYE DAMAGE MAY BE INCURRED.**
6. Use only xenon bulbs designated as OZONE FREE. When possible, vent the lamphouse exhaust to outside atmosphere.
7. Maintain the lamphouse blower in good operating condition. Keep the blower inlet clean for unrestricted air flow.
8. To insure maximum bulb life, operate the lamphouse blower and the exhaust system for at least ten minutes after extinguishing the bulb.
9. If returning a bulb for warranty adjustment, pack it in its original shipping container. Complete and return all required warranty information.

SAFETY PROCEDURES (continued)

10. Dispose of expired bulbs that are beyond warranty in the following manner: Wrap the bulb tightly in several layers of canvas or heavy cloth. Place it on a hard surface and shatter the envelope with a sharp hammer blow. DO NOT place an unshattered bulb in an ordinary refuse container.
11. DO NOT PERMIT UNAUTHORIZED PERSONNEL TO PERFORM OR ATTEMPT ANY PHASE OF XENON BULB HANDLING OR SERVICE.

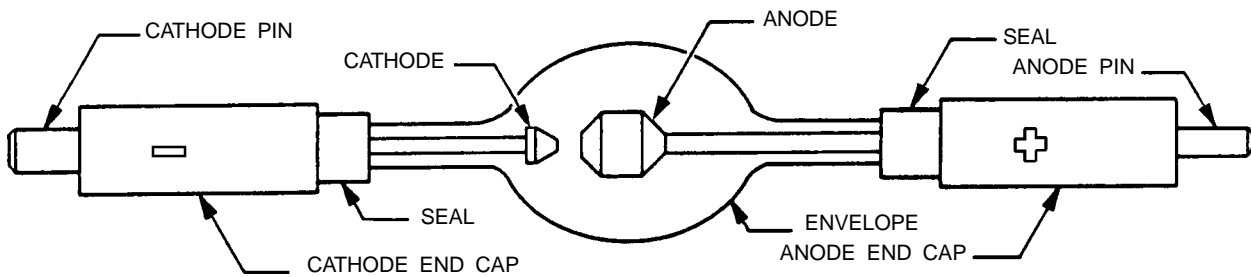

HIGHLIGHT II XENON BULBS

THE FOLLOWING XENON BULBS are approved for use in the Strong Highlight II Console. Bulbs not listed below must be certified by their manufacturer as being 100% interchangeable, and be classified as ozone-free. Dimensions of 5000 watt bulbs vary by manufacturer; *consult factory*.

<u>WATTAGE</u>	OSRAM® <u>Part No.</u>	Hanovia® <u>Part No.</u>	ORC® <u>Part No.</u>
1000	XBO1000W/HS OFR	XH1000HS	XM1000HS
1600	XBO1600W/HS OFR	XH1600HS	XM1600HS
2000	XBO2000W/H OFR	XH2000HW	XM2000H/VC
2000 (short)	XBO2000W/HS OFR	XH2000HS	XM2000HS
2500	XBO2500W/HS OFR	XH2500HS	XM2500HS
3000	XBO3000W/H OFR	XH3000HW	XM3000H/VC
4000-4500	XBO4000W/HS OFR	XH4200HS	XM4500HS*
7000 (70mm+)	XBO7000W/HS OFR	XH7000HS	XM7000HS*

* also available in H/VC configuration using 24180 Support Collet

BULB ADAPTERS are required for 1000 and 1600 watt bulbs only, and are supplied in the accessory kit only when these wattages are specified on the original equipment order. The adapters are designed for use with the 2000 watt bulb support collet 24179 (12mm I.D. socket).

THE CATHODE ADAPTER is drilled and tapped 5/16-18 to accommodate the threaded cathode pin used on the 1000 and 1600 watt bulbs. When screwed onto the cathode pin, the adapter positions the arc at the correct focal point. The chromed anode adapter mounts to the pin of the anode end cap, and rests in the bulb yoke in front of the reflector to support the front of the bulb. A lead is attached to the anode adapter to supply positive DC current.

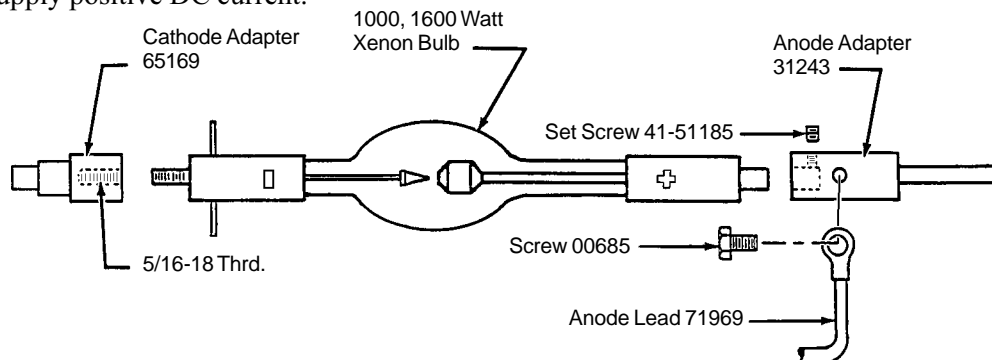

ASSEMBLE THE ADAPTERS to the 1000 or 1600 watt bulb prior to removing the plastic protective covering. DO NOT apply mechanical stress to the quartz envelope. Firmly tighten all fasteners before installing bulb and adapters.

XENON BULB INSTALLATION & OPERATION



Only qualified and trained professional technical personnel are allowed to operate the equipment. Refer service and maintenance to trained personnel. Untrained personnel are not allowed in the projection booth during operation, service, or maintenance.



OBSERVE ALL SAFETY PROCEDURES when working around the xenon bulb. Leave the bulb in its protective plastic cover whenever possible, and remove immediately any fingerprints accidentally placed on the quartz envelope.

OPEN THE LAMPHOUSE COMPARTMENT ACCESS DOOR and dismount the cover plate from the xenon bulb enclosure. Set the cover plate and thumb screws aside. Slide the contact clamp on the igniter lead over the rear bulb socket.

CONNECT THE ANODE LEAD to the positive (+) end cap of the xenon bulb if the lead is not factory attached. Tighten the connection firmly to insure a secure electrical contact and to prevent overheating.

HANDLE THE BULB by the metal end caps only. Insert the bulb into the reflector, passing the cathode (-) end cap through the center hole in the back of the reflector. Seat the cathode pin into the socket of the rear bulb collet as far as possible to permit full focus travel. Rest the anode (+) end cap in the bulb support yoke in front of the reflector.

SECURELY TIGHTEN the socket head clamping screw in the igniter lead contact clamp. Make certain the cathode (-) pin is firmly secured to the socket of the bulb collet. Attach the terminal of the anode (+) lead to the stud of the binding post located adjacent to the front bulb support. Dress the anode lead in front of the support yoke to minimize shadows. Tighten the fastening hardware securely to insure good electrical conduction.

REMOVE THE PLASTIC COVER from the xenon bulb. Replace the cover plate over the bulb enclosure and secure with the thumb screws. Close and lock the lamphouse compartment access door. Turn on the lamphouse exhaust system.

ENERGIZE THE CONSOLE AC INPUTS at the main breaker panel. Place the switching circuit breakers in the ON position. Rocker-type switches (when used) will light when energized. The POWER light on the analog lamphouse control panel will glow, or the backlighting of the LCD screen on the digital control panel will glow (see below paragraph). The cooling fans will start. Operation of the cooling and exhaust blowers will actuate the air flow switch, lighting the AIR indicator on the analog control panel. The DOOR indicator light will glow on analog units when all access doors are closed and locked.

UNITS EQUIPPED with the optional digital display include no indicator lights. POWER ON state is indicated by the display being backlit and showing zero current and voltage. Failure to turn on exhaust air or to secure access doors is displayed as "CHECK EXHAUST" or "CHECK DOOR." A flashing asterisk (*) indicates that the display is active and awaiting inputs. NOTE: the interlock detection circuit in currently manufactured Digital Display models features a (5) minute "bobble" delay to allow the exhaust blower to reach full speed and eliminate air flow backdrafts.

BULB INSTALLATION & OPERATION (continued)

IGNITE THE XENON BULB by pressing the LAMP rocker switch on the lamphouse control panel. When this switch is closed, the LAMP ON indicator light will glow, and the lamphouse control circuit will energize the coil of the xenon power supply contactor. When the initial high DC “no load” surge from the power supply reaches 130 volts, the DC Pulse Igniter will energize. The igniter will supply a high voltage pulse across the electrodes of the xenon bulb.

THE HIGH VOLTAGE IGNITER PULSE, coupled with the high DC open circuit (“no load”) voltage from the xenon power supply, will ignite the xenon bulb. A “cold” bulb will generally ignite after one pulse; a bulb still warm from prior operation may require two or three pulses. A short delay between ignition pulses, as power supply capacitors re-charge, is normal.

UPON IGNITION, the DC voltage will fall to the low sustaining level required for continuous operation. The DC Pulse Igniter ceases operation below 130 V.DC. Allow a minute for the current to stabilize, and check the operating current on the ammeter. The ammeter, located on the analog lamphouse control panel, constantly displays the DC current supplied to the xenon bulb. Pressing the AMP/VOLTS switch will momentarily display the DC arc voltage.

THE OPTIONAL DIGITAL DISPLAY will continuously read out DC current, arc voltage, operating wattage, and elapsed time. No switching is required to change display modes. The flashing asterisk symbol (*) will turn into a plus (+) sign until the bulb is extinguished.

ADJUST THE XENON POWER SUPPLY as required to provide the correct DC output to the bulb. Directions for adjusting the DC output of the xenon power supply are included in the separate Instruction Manual furnished with the power supply. Do not exceed the maximum current specified for the rated wattage of the bulb. See the warranty information packaged with the bulb and comply with the manufacturer’s recommendations. The following figures may serve as a guideline to complete installation; in the event of conflict, the bulb manufacturer’s figures shall prevail.

<u>Bulb Wattage</u>	<u>Nominal Current</u>	<u>DO NOT EXCEED</u>
1000	50 A.	58 A.
1600	65 A.	70 A.
2000	75 A.	90 A.
2500	90 A.	100 A.
3000	95 A.	100 A.
4200	135 A.	150 A.
5000	145 A.	155 A.
7000*	150 A.	160 A.

* Minimum Aperture: 70mm. Radiant Energy levels will damage 35mm prints.

BULB INSTALLATION & OPERATION (continued)

A NEW BULB is normally operated at or slightly below the “nominal” current level. As the bulb ages, the quartz envelope will darken and the light output will decrease. To restore the light output, the operating current can be gradually increased to, but not exceeding, the maximum current. Because of manufacturing tolerances on xenon bulbs, one lamp in a two-machine booth may operate at a slightly higher or lower current setting than the other to balance the light on the screen.

ONCE OPERATING at its correct current setting, the xenon bulb must be positioned inside the reflector to project its optimum light field. The bulb positioning mechanism is mounted to the back of the bulb enclosure inside the lamphouse compartment, and is accessible through the small hinged door in the rear console access door.

BULB ADJUSTMENT CONTROLS

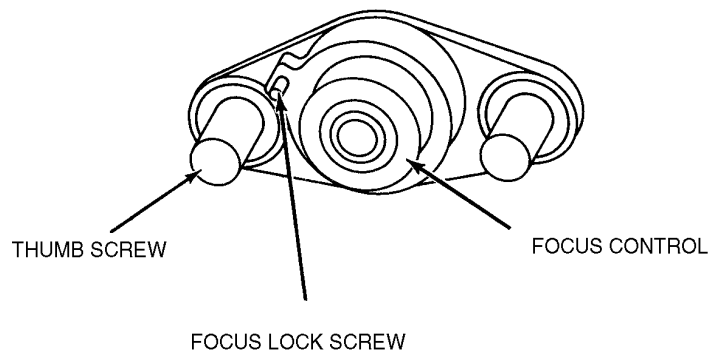

THE CENTER SECTION of the control is a threaded member that focuses the bulb in relation to the reflector. Turning this adjustment moves the bulb in only one plane, into or away from the reflector. Clockwise rotation moves the bulb away from the reflector. The small knurled screw to the left of this section can be tightened to lock the focusing mechanism, after the following procedures have been completed.

THE THUMB SCREWS on either side of the focusing control lock the horizontal and vertical adjustment mechanism in position. The thumb screws are spring-loaded to apply a degree of tension between the mechanism housing and the back of the bulb enclosure.

REMOVE THE PROJECTION LENS, start the projector motor and open the lamphouse douser. Since a xenon light source can be focused to a small, intense spot at the projector trap, do not operate the lamp with the douser open without first starting the projector motor.

THE IMAGE projected to the screen, without the projection lens, is that of the center hole of the reflector, and the shadow of the anode (the larger of the two electrodes in the xenon bulb). The projection of the anode shadow will appear on the screen as a darker spot surrounded by the grey area of the reflector center hole.

BULB INSTALLATION & OPERATION (continued)

TURN THE CENTER FOCUSING SECTION of the bulb positioning control until the smallest black spot obtainable is focused on the projection screen. It may be best to run this adjustment both directions to permit positive identification of the spot. The position of the spot may be to the right, left, top or bottom of the screen, and not necessarily at the center.

LOOSEN the two thumb screws, one on either side of the focusing section just enough to permit manual movement of the complete assembly. The bulb adjustment control will now move about these two thumb screws, and as this control is shifted, the smooth shadow of the electrode can be seen extending beyond the projected hole in the reflector. The electrode shadow must be centered in the projected hole of the reflector.

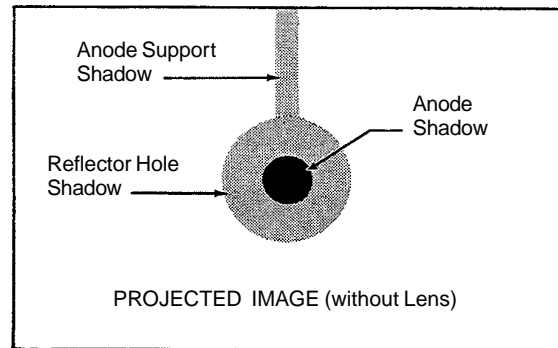

MOVE THIS CONTROL SECTION around the two thumb screws until the black spot is as round as possible to project. The two thumb screws are spring-loaded to apply a degree of tension to the control section. It may be necessary to again adjust the focus control to define a sharp spot. If the bulb adjustment control is at its extreme limit of travel (left-to-right or top-to-bottom), shut off the lamp, allow the bulb to cool, and open the lamphouse door. Remove the stainless steel bulb enclosure cover and loosen the set screw securing the front bulb yoke. Re-position the yoke left-to-right or up-and-down to compensate.

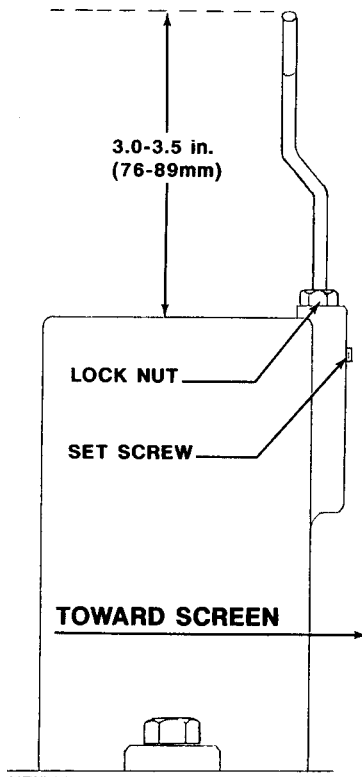

THE FRONT BULB SUPPORT YOKE is adjustable and is factory-set to accommodate the end cap diameter of the xenon bulb specified on the sales order. A height of 3-1/8 to 3-1/4 inch is normal for most commonly used bulbs, but bulbs with larger diameter end caps (i.e. ORC 4500 and 7000 watt models) may require setting the yoke as low as three inches. To adjust the yoke position, loosen the set screw in front of the yoke, and raise or lower the yoke as required. A hex nut is provided to lock the height once selected. Re-tighten the set screw when finished.

AFTER THE BLACK SPOT is as even around the outside as possible to project, and centered in the shaded area as shown above, tighten the two thumb screws to lock the adjustment section. This adjustment has now centered the projected image of the electrode shadow and the hole in the reflector on the aperture and screen. If the spot raises or lowers as the focus screw is turned, it is necessary to re-adjust the front bulb yoke as instructed above.

BULB INSTALLATION & OPERATION (continued)

TO ALLOW FOR MANUFACTURING TOLERANCES in overall bulb length and/or fabrication of the stainless steel bulb enclosure, an additional degree of fine adjustment is available by changing the position of the snap ring(s) retaining the bulb support collet in its bearing. Use this feature only if the proper focal position cannot be gained by use of the focus screw.

TO REPOSITION THE COLLET, extinguish the bulb and allow the lamp to cool. Observing all safety precautions, remove the xenon bulb. From the rear of the bulb enclosure, remove the 21-48027 Snap Ring (see Detail drawing, Figure 3 Parts List) and withdraw the collet from the inside of the bulb enclosure. Position the inner snap ring as required, and re-install the collet by securing the outer snap ring.

IF THE PROJECTED IMAGE is not centered on the screen as illustrated, move the console or adjust the tilt to correct. It is necessary to dismount the off-operator side blower panel to access the left tilt lock. See the illustration on the WIRING INSTRUCTIONS page.

REPLACE THE PROJECTION LENS and install a CinemaScope aperture plate. Turn the center focus adjustment until the desired light distribution is projected to the screen. Avoid running the projector in this manner for an extended period of time without *frequently* closing the lamphouse douser. Without film, the heat from the xenon bulb can damage the projection lens.

THE IDEAL “FLAT” FIELD denotes a pattern of light without a distinct “hot” spot in the center of the screen, and only a slight reduction of light in the four corners. Establish the desired field using the 35mm CinemaScope aperture plate, and DO NOT alter the bulb focus when projecting a “flat” 35mm print. An optional Beam Expander Kit is required for 70mm operation; see the following section entitled “70mm OPERATION” for further details.

IF A “HOT” SPOT REMAINS in an otherwise even field, turn the LAMP switch OFF and allow the xenon bulb to cool. Open the access door and remove the side cover plate of the bulb compartment. Loosen the set screw locking the position of the bulb support yoke, and move the yoke to “point” the front end cap of the bulb away from the “hot” spot. Replace the bulb compartment cover, close and lock the access door, and re-ignite the xenon bulb. Repeat the manipulation of the bulb adjustment mechanism to establish an even field.

TO EXTINGUISH the xenon bulb, turn the LAMP rocker switch on the lamphouse control panel to its OFF position. The LAMP ON indicator light (when used) will extinguish. Leave the console power ON to permit the blowers to operate and cool the bulb. Allow the blowers to operate for at least ten minutes after turning off the xenon bulb. A forced-air cooling cycle is required by xenon bulb manufacturers in order to comply with bulb warranty requirements.

RECORD THE HOURS of xenon bulb operation on the inside back cover of this manual. Use the (HR) figure displayed on the digital unit, as this figure indicates total system hours. Instructions for re-setting the (BLB) display follow in the DIGITAL DISPLAY section.

BULB INSTALLATION & OPERATION (continued)

WHILE XENON BULBS generally will perform well beyond their stated warranty life, no credit will be allowed by the bulb manufacturer for damaged reflectors in the event of an explosion if the bulb is past its warranty period. This should be considered when determining the time of bulb replacement.

UPON REPLACING THE XENON BULB, it will be necessary to repeat only the bulb alignment procedures outlined above. Adjustments detailed in the OPTICAL SYSTEM ALIGNMENT section are required only when a reflector is replaced.

BULB ROTATION:

MOST XENON BULB MANUFACTURERS recommend and/or require rotation of horizontal bulbs at 50% warranty life. Refer to the warranty information packaged with the xenon bulb for specific requirements.

TO ROTATE THE BULB, loosen the socket screw in the cathode clamp and remove the anode lead terminal from the positive binding post. Rotate the bulb 180 degrees, re-attach the anode lead terminal, and tighten the cathode clamping screw.

IF THE BULB'S ANODE LEAD is too short to reach the binding post from the rotated position, an anode lead extension with fittings is available from Strong International Dealers. Order (1) each of Lead Extension 71928, Connector 81349, and Insulation Tubing 71289.

ADJUST THE XENON POWER SUPPLY to increase operating current to or just below the maximum level specified for the bulb. Project a white light to the screen to check for an even field and correct the bulb positioning as required. Operate the xenon bulb at this higher current level for one or two performances, and then return the power setting to its previous level. Temporary operation of the bulb at high current following bulb rotation will restore the cathode tip and enhance ignition at the new arc position.

BULB WARRANTY RETURNS:

RETURN BULBS upon which a warranty claim is being made to the theatre equipment dealer through whom the bulb was purchased. Pack the bulb in its original shipping carton with the protective cover over the bulb. Complete and enclose all warranty forms supplied by the bulb manufacturer.

WARRANTY CREDIT will *not* be allowed if the bulb failure is related to mishandling, incorrect installation, faulty supporting equipment, or abuse.

REFLECTORS damaged by a bulb explosion should be forwarded to the *bulb* supplier for warranty adjustment. Include an invoice copy authenticating the cost of the replacement reflector.

ARC STABILIZING MAGNET ADJUSTMENT

THE ARC STABILIZING MAGNET is located on the lamp base in front of the reflector. This magnet is preset at the factory and should not require adjustment.

IF IT SHOULD BECOME NECESSARY to adjust the magnet, the following procedure must be followed. Observe all safety procedures when working in the lamphouse compartment.

THE NORMAL ARC, when viewed through the arc viewing port, will appear as in Figure A. This represents the correct magnet position.

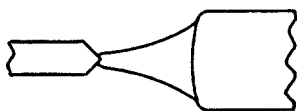

FIGURE A

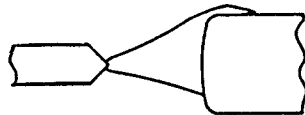

FIGURE B

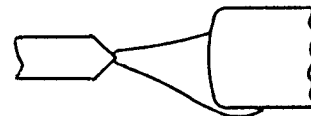

FIGURE C

FIGURE B shows the position of the arc when the magnet is too low. Raise the magnet on its adjustment bracket to lower the arc to the position illustrated in Figure A.

FIGURE C shows the position of the arc when the magnet is too high. Lower the magnet to raise the arc to the position illustrated in Figure A.

THE MAGNET must always be installed with the longest portion of the magnet nearest the bulb, and with the SOUTH (S) pole pointing to the operator side access door. Reversing the magnet will cause bulb flicker, and may inhibit bulb ignition.

IN NEW EQUIPMENT, the magnet is normally in the center of the adjustment range. Changes in the magnet position are required only to correct an improperly burning arc (Figure B or C).

ANY REPLACEMENT MAGNET should first be installed in the center position of the adjustment range. Raise or lower the magnet as required to center the arc as illustrated in Figure A.

70mm OPERATION

BECAUSE OF THE LARGER APERTURE AREA of a 70mm projector, it is necessary to incorporate a beam expander lens to insure proper coverage of the screen. The Beam Expander Kit No. 40959 is factory installed when ordered with new equipment, or may be added to an existing installation at a later date.

THE KIT consists of a lens holder (81847) which mounts to the front casting of the lamphouse with three 1/4-20 x 1-1/8" hex head screws (705) and three 1/4" washers (863), a lens assembly (81848), and a nose cone (40960). The sheet steel nose cone mounts to the lens holder with three 6-32 x 1/8" pan head screws (1412).

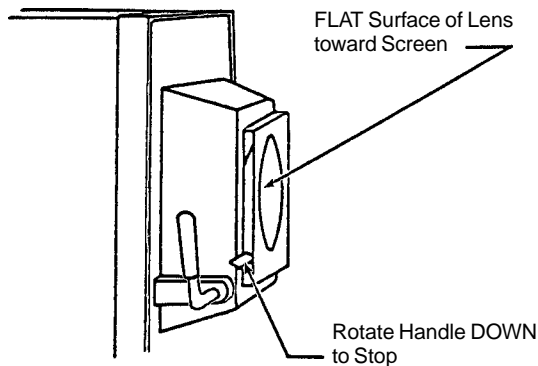

ALL CONSOLE front castings are drilled and tapped to accommodate field installation of the Beam Expander Kit. The nose cone can be trimmed with tin snips to fit as required without disturbing the 33-1/8 inch working distance of the lamphouse reflector to the projector aperture.

THE 70mm LENS is inserted as illustrated ONLY for 70mm operation; DO NOT insert the lens for 35mm projection.

MINOR REFOCUSING of the bulb may be required after insertion of the beam expander lens. Prior to projecting the 70mm film, project a white light to the screen with the projector running. Adjust the center member of the bulb adjustment mechanism until the desired light distribution is projected to the screen. Again, avoid running the projector in this manner for a prolonged period without *frequently* closing the douser to cool the projection lens.

THE BEAM EXPANDER LENS should be cleaned periodically with lens tissue and a lens cleaning solution suitable for coated lens.

LENS HOLDER 81847, as illustrated above, can also be used with a Heat Filter & Ring Assembly (40939) when running 35mm prints. This optional heat filter may be desirable if a high wattage bulb (4500-5000 watt) is routinely used for 35mm projection.

MAINTENANCE



WARNING: OPEN AC DISCONNECT BEFORE SERVICING UNIT.



THE STRONG HIGHLIGHT II CONSOLE requires very little maintenance to keep it in good working order. Routine cleaning of the equipment is the most important element, and cleaning intervals are determined by the dirt and dust conditions at the installation site.

THE REFLECTOR should be cleaned with a soft, clean, dry cotton cloth every two weeks. If excessively soiled, a commercial liquid glass cleaner may be used. *Use no abrasives.* Exercise extreme care not to scratch or fingermark the coated surface.

CHECK ALL ELECTRICAL CONNECTIONS periodically for tightness. Particular attention should be paid to the DC connections at the bulb, the shunt, and the positive binding post.

THE BULB should be checked regularly for presence of dirt or foreign material on the envelope. Dirt or foreign material must be removed from the bulb immediately, or they will burn into the quartz envelope and shorten bulb life. NOTE: Observe all safety procedures when working around the bulb.

THE INSIDE of the lamphouse compartment and the blower intakes should be cleaned periodically, depending on the dust conditions at each installation. Keep all air inlet grilles clean and free from obstructions.

BOTH THE FRONT AND TOP LAMPHOUSE BLOWERS require periodic lubrication. Oil holes in the blower motor end bells are marked, and use of a squeeze-type, plastic injection oiler is recommended. NOTE: blower motors are thermally protected, and failure to routinely service them could cause overheating and periodic shutdowns. Interruption of the air flow will open lamphouse interlock switches and extinguish the xenon bulb.

TO EXPOSE THE OIL HOLES of the front blower, dismount the motor cover by removing the two mounting screws. Both oil holes of the top blower motor are accessible by removing the frame and grille assembly from the off-operator side of the top blower cover. Apply a few drops of machine oil in each oil hole once or twice a year. Wipe off excess oil to prevent dust attraction.

TWO SIX-INCH BLOWERS at the bottom of the off-operator side panel are required only when the console uses a high reactance xenon power supply. These blowers, like the built-in blowers used in the switching power supply, utilize sealed bearings and require no lubrication.

DIGITAL DISPLAY

UPON ENERGIZING the LAMP circuit, the backlighting will illuminate the LCD screen. When all blowers are operating and all access doors are closed and correctly secured, the display will appear similar to the example shown:

000V 000A 0000W
1234BLB 12345HR *

FOR PURPOSES OF ILLUSTRATION, the above display indicates a non-operating bulb with 1,234 hours of use installed into a console with 12,345 hours of operation. The asterisk (*) at the end of the second line, when flashing, indicates that the display is active and awaiting input. Upon bulb ignition, the upper line will display the arc voltage (V), the DC current (A), and the operating wattage (W) of the bulb. The figures will shift for the first few moments of bulb operation, but will stabilize after the bulb reaches operating temperature and pressure. A plus symbol (+) will replace the flashing asterisk.

IN THE EVENT of an open interlock switch, the lower line will display the appropriate diagnostic measure, i.e. CHECK REAR DOOR or CHECK EXHAUST. Diagnostic messages are often abbreviated, and are defined as follows:

- CHECK REAR DOOR:** Make certain the rear console access door is closed, locked, and the locking screw into the lock plate is installed (if unit is equipped with mechanical interlock switches).
- CHECK FRONT DOOR:** Make certain the operator's lamphouse access door (right side, viewed from rear) is closed, locked, and the locking screw into the (mechanical) lock plate is installed.
- CHECK NONOP DOOR:** Make certain the lamphouse access door on the off-operator (left) side is closed, locked, and the locking screw into the (mechanical) lock plate is installed.
- CHECK EXHAUST:** Make certain the exhaust blower has been switched on and is operating without obstruction. A five minute "bobble" delay in this circuit permits the exhaust blower to reach full speed and eliminate air flow backdrafts.
- CHECK TOP BLOWER:** Make certain the large squirrelcage blower on the top of the console is energized and operating, and that the ducting to the bulb compartment is secure.

WHEN THE INTERLOCK CIRCUIT is complete, closure of the LAMP switch, or the automation closure, will energize the contactor of the xenon power supply. The high open circuit ("no load") DC voltage will be displayed. When the open circuit voltage reaches 140 V.DC, the igniter will generate a RF pulse to bridge the gap between the bulb electrodes. This pulse, coupled with the high open circuit DC voltage, will ignite the bulb. The voltage reading will then fall to the bulb's sustaining level, and the DC amperes (A) and wattage (W) will be displayed continuously until the bulb is extinguished. The flashing asterisk symbol (*) will become a plus (+) sign.

DIGITAL DISPLAY (continued)

ELAPSED HOURS will begin counting upon bulb ignition. Bulb hours (BLB) are limited to four digits, and can be re-set when the xenon bulb is replaced. To re-set bulb hours, press and hold (for 3 seconds) the RESET button accessible through marked hole below the LCD screen. The 5/64" allen wrench used to tighten the front bulb yoke set screw is the correct diameter to clear the hole. NOTE: when recording start-up and removal hours on the Xenon Bulb Record, use the *total elapsed hours* (HR) figures. The (BLB) figure, re-set upon installation of the bulb, is a convenience feature ONLY. Basing records of the lamp system on the total hours (HR) figures permits an accurate and ongoing history of bulb usage.

IF THE XENON BULB fails to ignite, additional diagnostic messages will display on the LCD screen:

CHECK PWR SUPPLY: If no DC current is sensed, and voltage does not exceed 125 V.DC, check the xenon power supply. Repair or replace as required.

CHECK IGNITER: If the DC open circuit voltage reaches and exceeds 140 V.DC and the igniter fails to pulse, replace the igniter.

PRESSING and rapidly releasing the RESET button will display the last recorded diagnostic message. The message will be erased after power is shut off. NOTE: Pressing *and holding* the RESET button will set the BLB display to zero.

DIAGNOSTIC MESSAGES serve as prompts and suggestions but do not replace traditional troubleshooting procedures. If an access door is closed and secured but transmits an error message, check the subject door interlock switch with an ohmmeter and replace if defective. Dirt or dust fouling an air vane switch will cause a "blower" or "exhaust" error message. A "power supply" or "igniter" error message might be caused by a loose or oxidized connection.

HIGHLIGHT II LAMPHOUSE

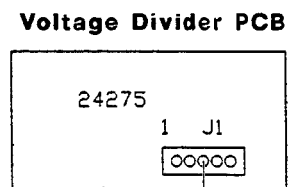
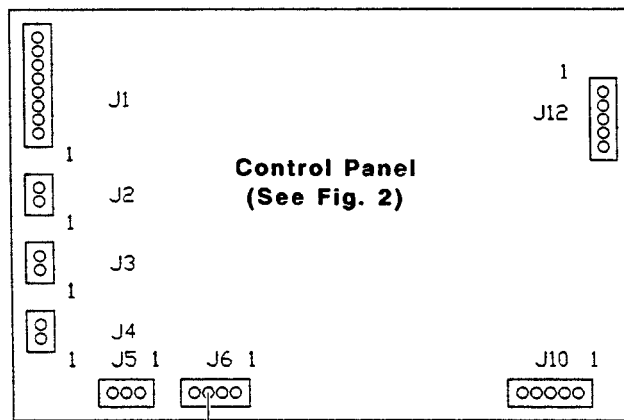
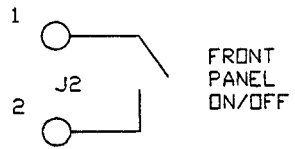
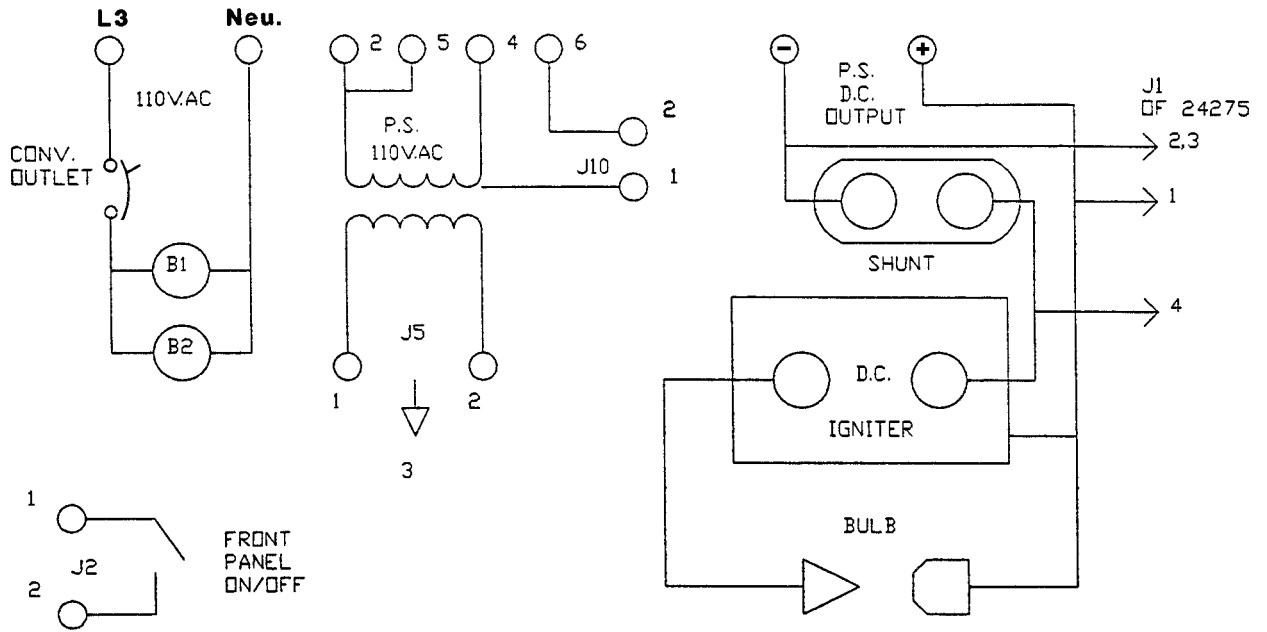

Xenon Bulb Ignition
& Monitor Circuit

24250 LAMPHOUSE WIRE HARNESS

The Highlight II Lamphouse Wire Harness Assembly is designed to permit use of either the Analog or Digital Control Panel without revision to lamphouse wiring. See Figure 2 for details of the two Control Panels.

Individual component parts (switches, etc.) of the 24250 Wire Harness are available as replacement parts. See the Parts List following the Wiring Diagrams.

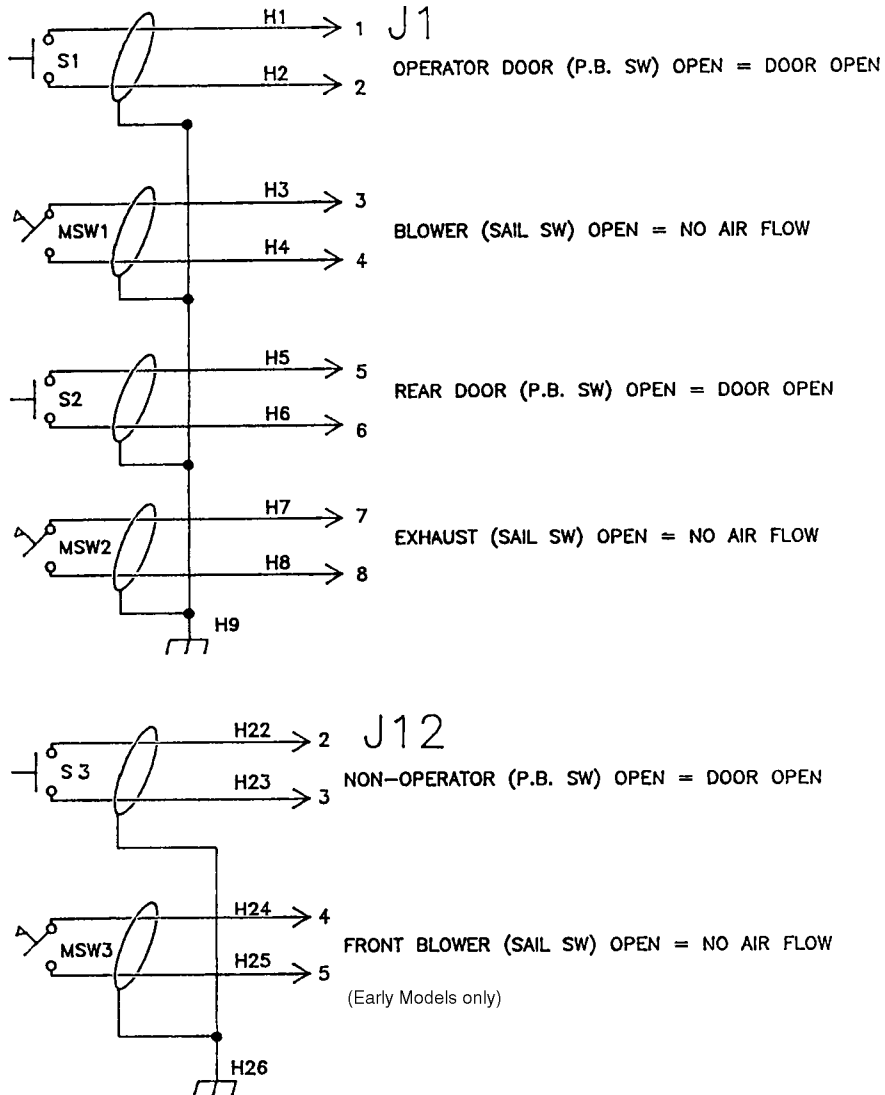

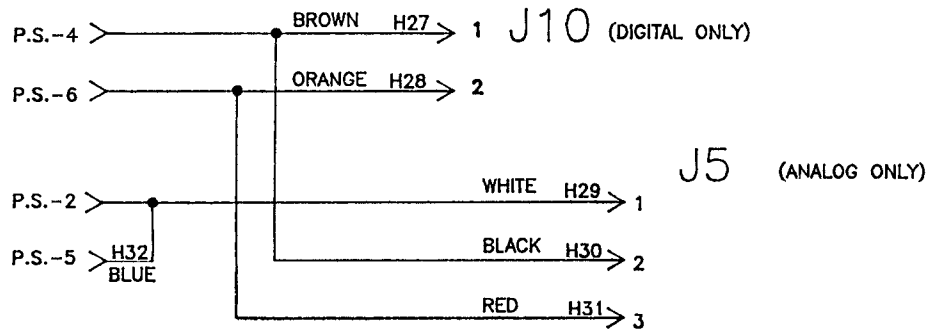
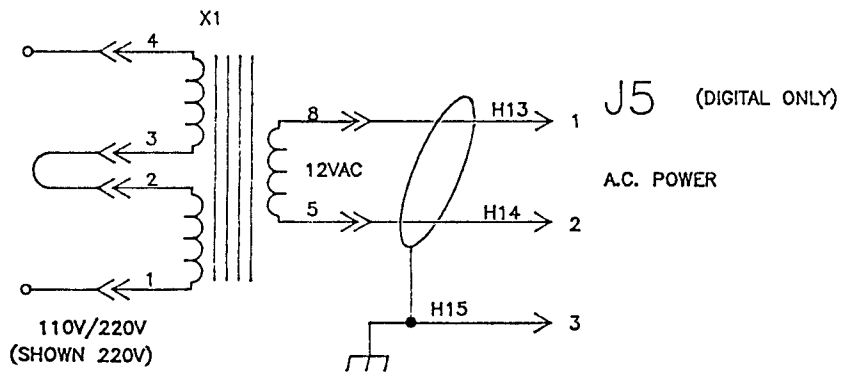
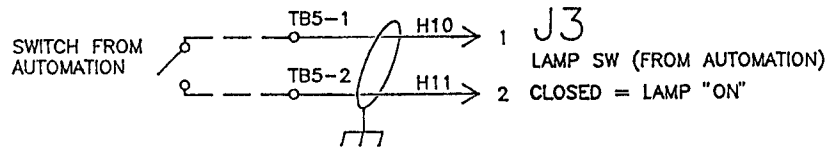

24275 Voltage Divider
PCB Assembly
(mounts to R1 Shunt)

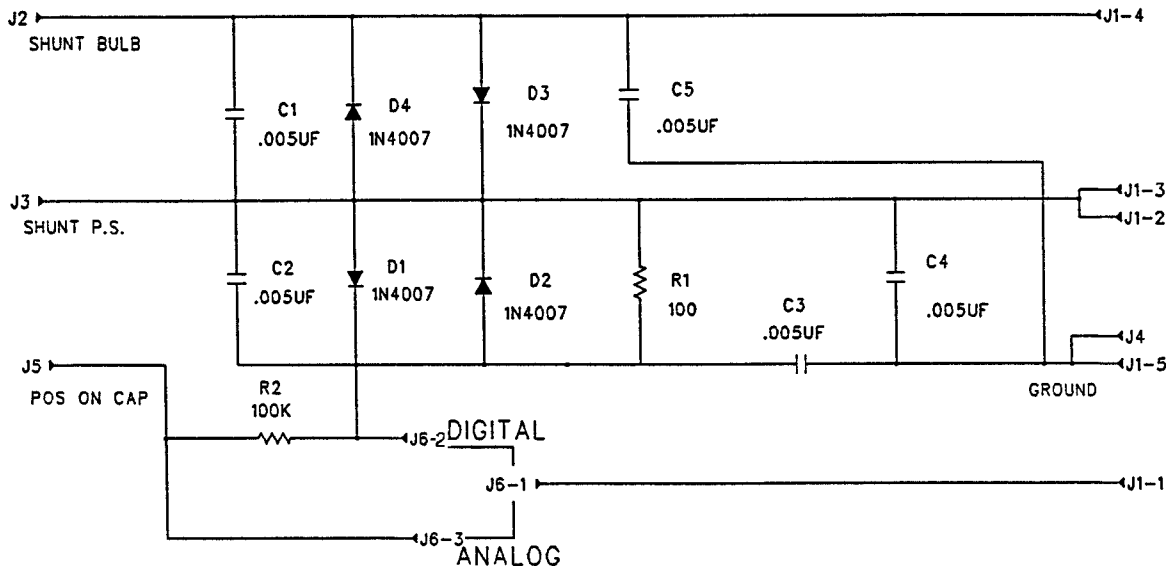
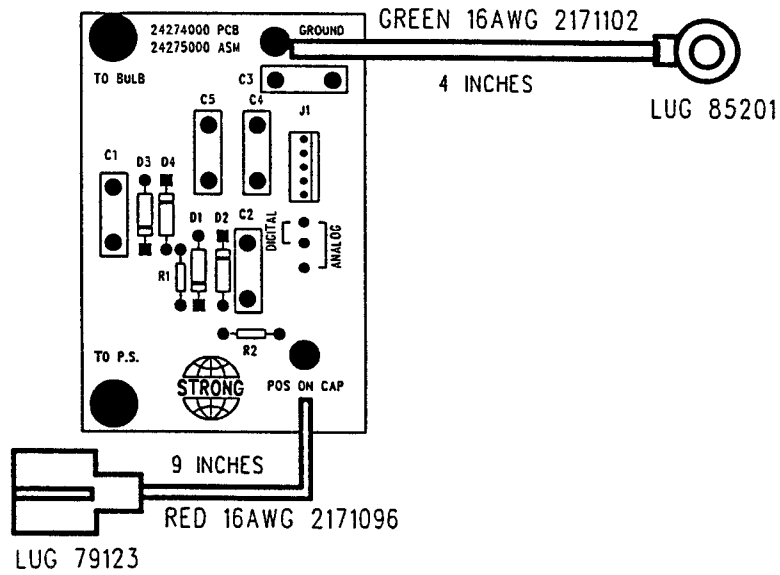

PARTS LIST
Lamp Control Wire Harness
Assembly No. 24250

Ref.			
<u>Desig.</u>	<u>Part No.</u>	<u>Description</u>	
IGN	39862	DC Pulse Igniter Assembly (with Switching Power Supply)	
IGN	39865	DC Pulse Igniter Assembly (with High Reactance Power Supply)	
J1	21-37058	Connector, (8) Position	
J3	21-37055	Connector, (2) Position	
J5	21-37056	Connector, (3) Position	
J10	21-37057	Connector, (5) Position	
J12	21-37057	Connector, (5) Position	
MSW1	85109	Microswitch, Air Flow; Top Blower	
MSW2	85109	Microswitch, Air Flow; Exhaust Stack	
MSW3	78133	Microswitch, Air Flow; Front Blower (early models)	
R1	82167	Shunt, 200 A. 50 mV.	
S1	24406*	Door Interlock Switch, Lamphouse Access, Operator Side	
S2	24406*	Door Interlock Switch, Rear	
S3	24406*	Door Interlock Switch, Lamphouse, Off-Operator Side	
X1	11-64004	Transformer, 110/220 V.	
—	56428A	Terminal, Spade Lug	
—	41-62027	Terminal, Auto Clip (Push-On)	
—	80195A	Terminal, Ring	
—	81252	Butt Splice Connector (Small)	
—	94262	Butt Splice Connector (Large)	

* Replaces 39260 used on earlier models. See Figures 3 & 4.
See 24406 *Detail* drawing on Figure 4 Parts List.

Voltage Divider PCB
Assembly No. 24275

Ref.			
<u>Desig.</u>	<u>Part No.</u>	<u>Description</u>	
C1-C5	61-08025	Capacitor, .005 μ f, 3 kV.	
D1-D4	51-17001	Diode, 1N4007	
PCB	24274	Printed Circuit Board (less Components)	
R1	61-46002	Resistor, 100 Ohm, $\frac{1}{4}$ Watt 5%	
R2	61-46043	Resistor, 100k Ohm, $\frac{1}{4}$ Watt 5%	
J1	21-37051	Connector, (5) Position	

23976 DIGITAL DISPLAY CONTROL PC BOARD

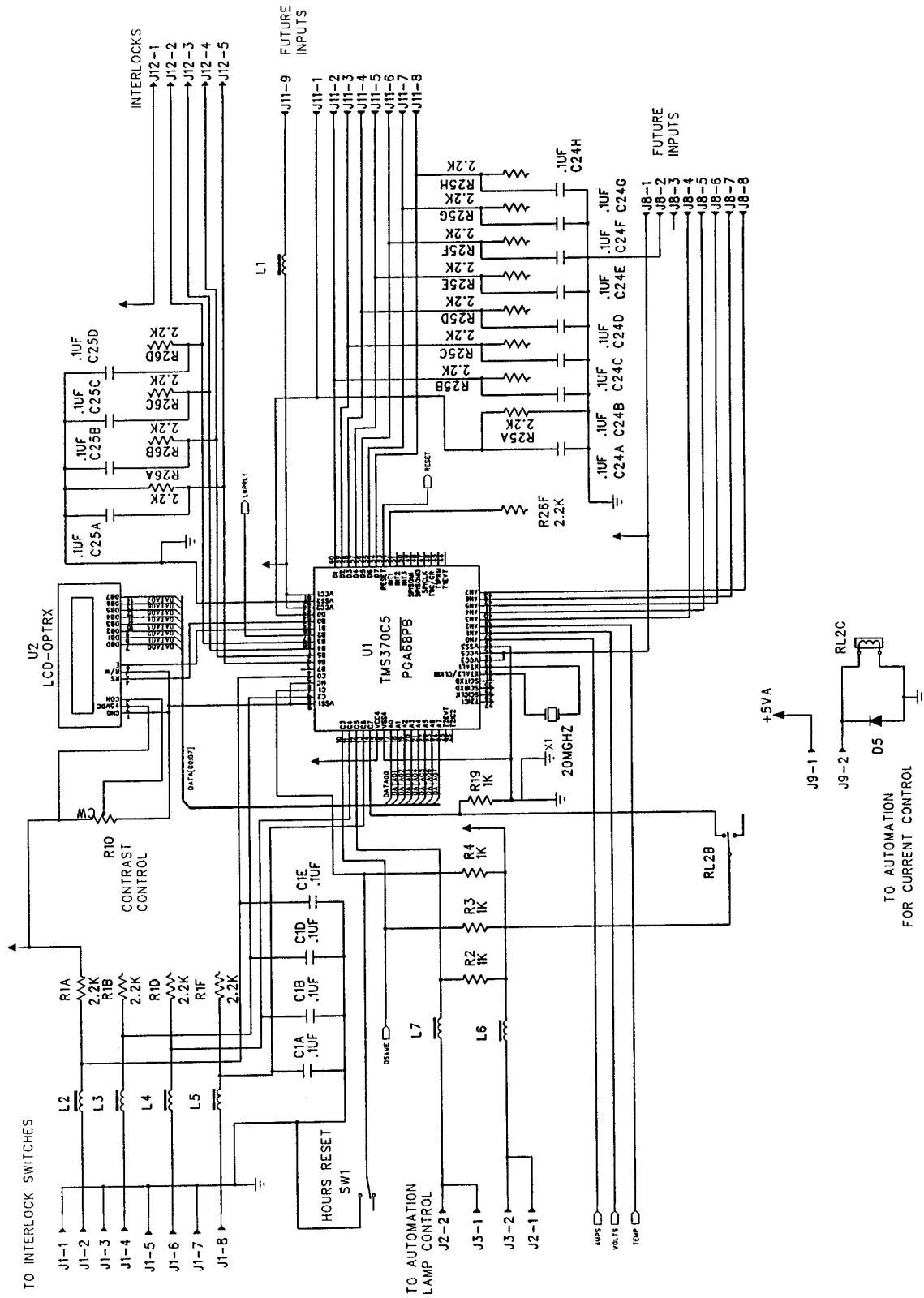

Wiring Diagram
Page 1 of 3

23976 DIGITAL DISPLAY CONTROL PC BOARD

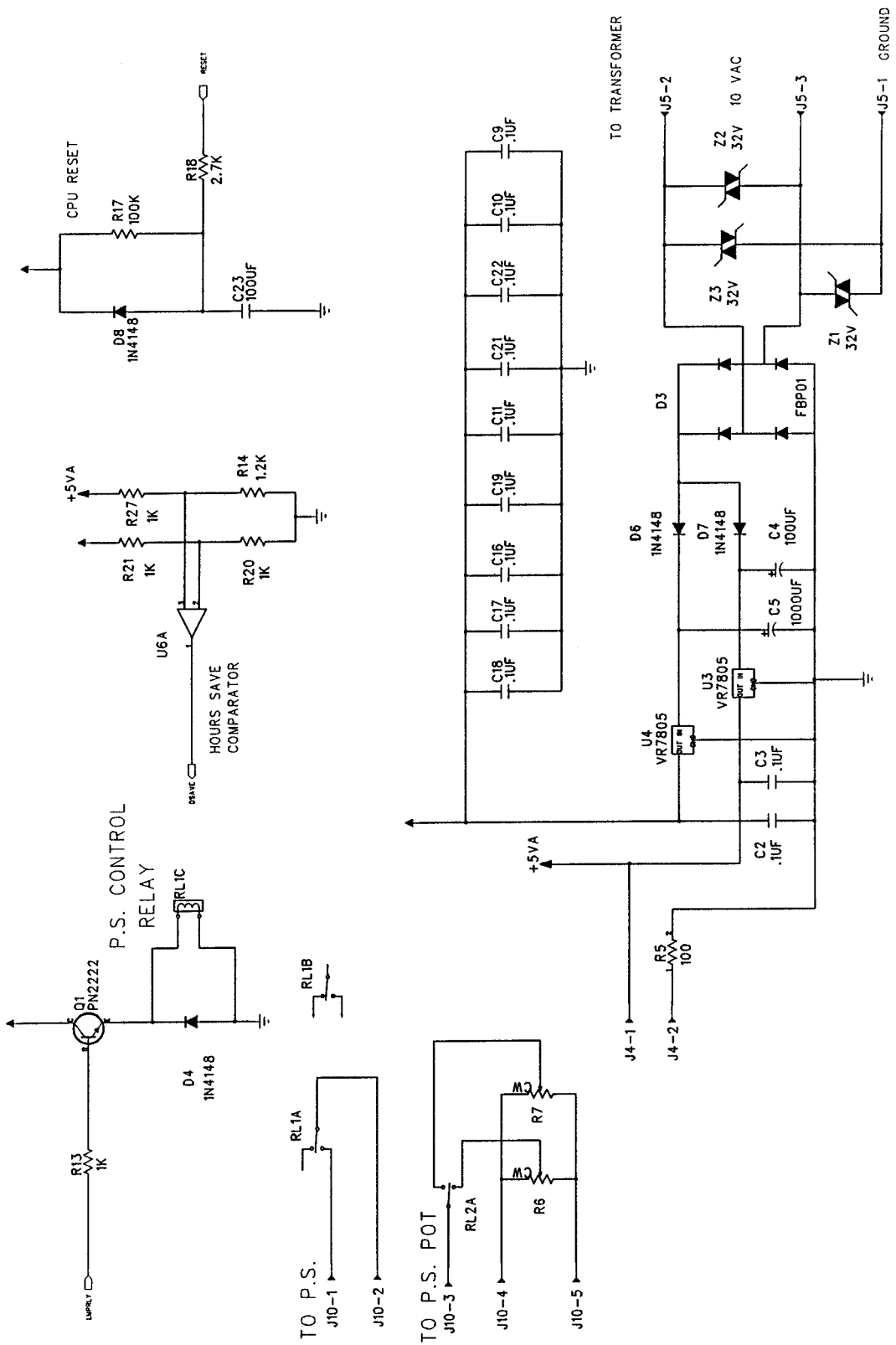

Wiring Diagram
Page 2 of 3

23976 DIGITAL DISPLAY CONTROL PC BOARD

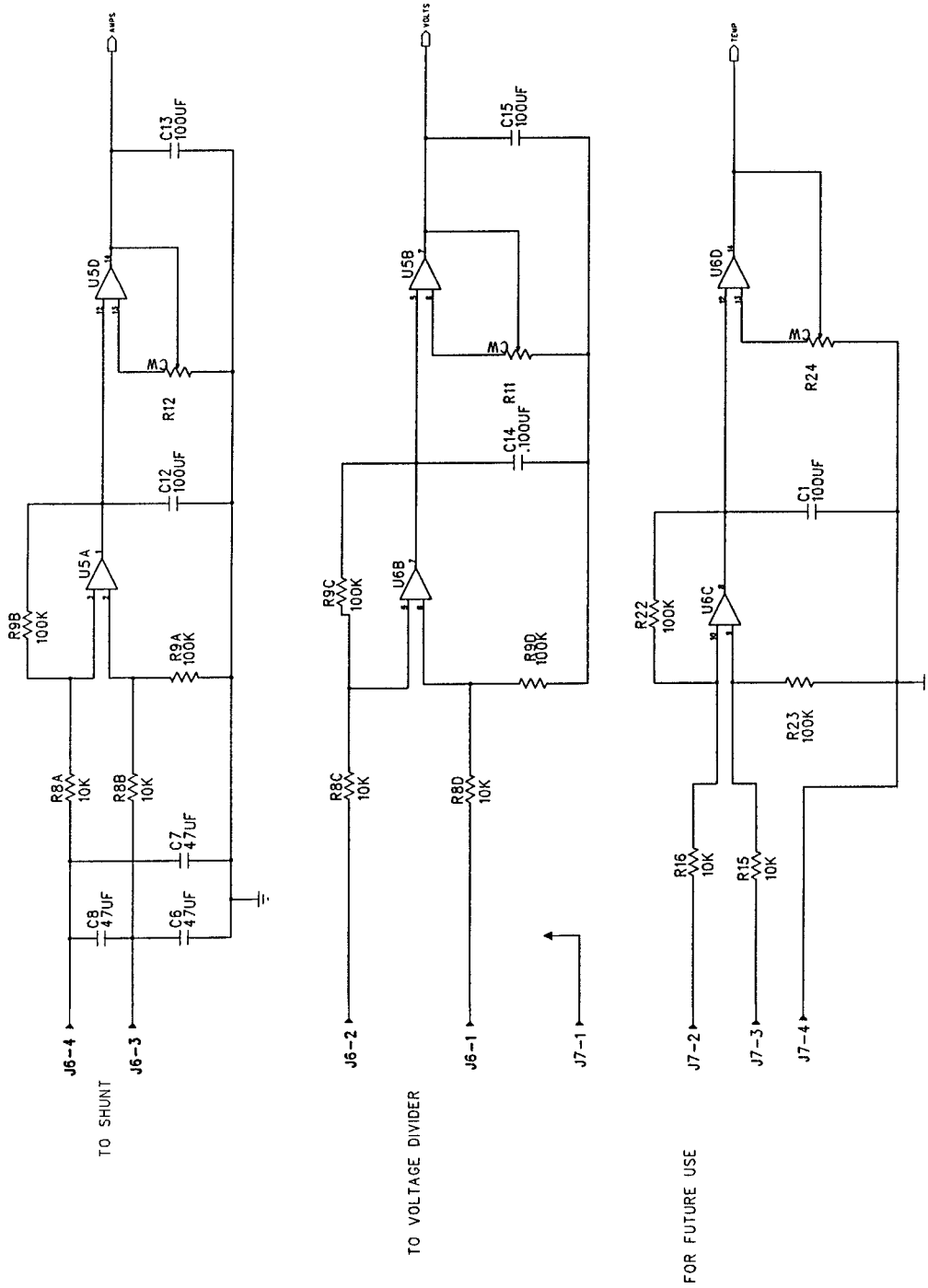

ANALOG LAMPHOUSE CONTROL PANEL

Assembly No. 23236

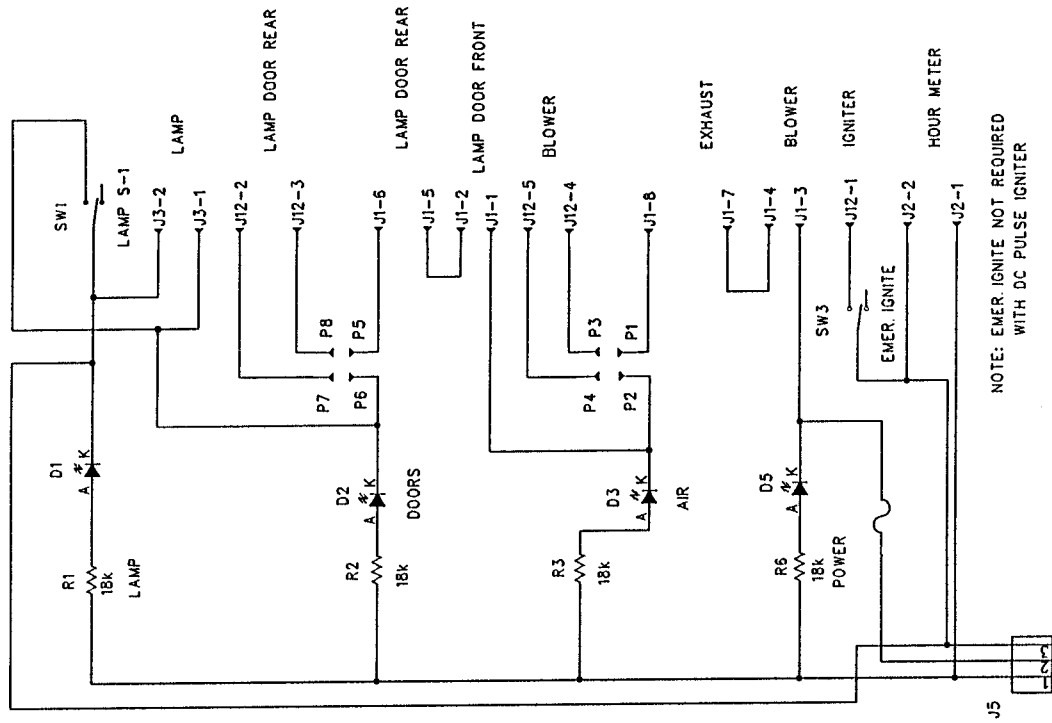

NOTE: EMER. IGNITE NOT REQUIRED
WITH DC PULSE IGNITER

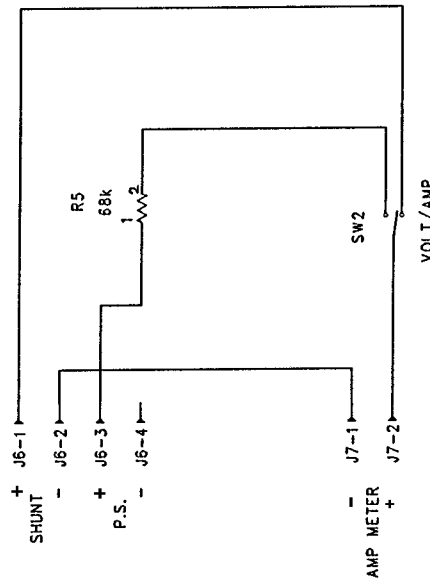

See Figure 2 for Parts List.

TROUBLESHOOTING

IN THE EVENT of an ignition failure, check first the indicator lights mounted to the analog Lamp Control Panel. The digital display will read out items to inspect and conditions to correct.

INDICATOR LIGHT FUNCTIONS: (Analog Units)

- “POWER”** When lit, AC power is supplied to the lamphouse, and to those branch circuits of the console which are switched ON. The lamphouse blowers will operate.
- “LAMP”** This indicator lights only when the control circuit is complete, meaning all access doors are closed and locked, and the bulb seal blowers are operating and supplying adequate air flow across the xenon bulb. This light also indicates that the xenon power supply contactor is pulled, and DC current is applied to the xenon bulb.
- “AIR”** Closure of the air flow switches, indicating adequate ventilation, will light this bulb. Air flow switches are located inside the bulb compartment at the top blower outlet and at the exhaust stack.
- “DOOR”** The (3) door interlock switches, at both operator lamphouse access doors and the at rear door, must be closed and locked to actuate this light. Locking screws, when supplied with mechanical interlock switches, must secure access door lock tabs. Magnetic interlock switches do not require locking screws, but key locks must be secured to insure switch closure.

The “POWER,” “AIR,” and “DOOR” indicators on the analog control panel must all be lighted to indicate that conditions are correct for ignition of the xenon bulb. The MAIN LINE circuit breaker must be in the ON position. The “LAMP” indicator (analog units) lights only when the circuit for bulb ignition is complete.

The elapsed time meter indicates running time only when the xenon bulb is operating. This provides an accurate record of bulb life. A defective elapsed time meter will not prevent bulb ignition.

The control circuit of the Strong Highlight II operates on 115 V.AC. *Exercise extreme caution when taking readings inside the console enclosure.* Do not open the lamphouse enclosure until the bulb has cooled to room temperature and the power supply and igniter capacitors have drained for (10) minutes.

Observe all safety procedures when working around the xenon bulb. If the quartz envelope of the bulb is accidentally touched, remove all fingerprints with alcohol before igniting the bulb.

TROUBLESHOOTING (continued)

NORMAL OPERATION:

The igniter operates from the high DC open circuit voltage furnished by the xenon power supply when energized. The 115 V.AC control circuit (5 & 6), which is energized when interlock and air flow switches are closed, and the LAMP ON closure is completed, actuates the power supply contactor. The igniter then generates the high voltage RF pulse to bridge the bulb arc gap. The RF pulse, combined with the high open circuit DC voltage, are necessary to ignite the bulb.

To accommodate different open circuit voltage characteristics, (2) DC Pulse Igniter Assemblies are available for use in the Highlight II console. Units equipped with switching-type xenon power supplies use Igniter 39862, and consoles with high reactance power supplies use 39865. Check the Part Number stamped on the case of the igniter.

There will be a distinct buzzing sound at the moment the xenon bulb ignites. This is caused by the spark gap in the igniter, and the high voltage arc between the bulb electrodes.

A short delay (two to three seconds) between contactor closure and the ignition pulse is not abnormal. This delay allows power supply capacitors to charge. A similar delay between strikes is normal in the event multiple ignition pulses are needed; a "warm" bulb, or a bulb nearing expiration, sometimes require more than one ignition pulse.

When the bulb ignites, the DC voltage drops to normal bulb operating range. The igniter ceases operation at voltages below 130 V.DC.

VISIBLE INDICATIONS OF MALFUNCTION: (Analog Control)

1. No "POWER" light. Check main circuit breaker or fuse; check AC supply at source.
2. No "AIR" light. Check bulb seal blowers; replace, repair, clean or lubricate as required. Check air vane switches (0 Ohms across contacts).
3. No "DOOR" light. Side or rear access doors open or unlocked. Defective interlock switch; check with ohmmeter for complete closure.
4. No "LAMP" light. Assuming all other indicator lights are ON, check for loose or missing connection in the 5 & 6 circuit; failure in automation circuit.

DIGITAL DISPLAY units will read out sequential inspection points and tests.

Bulb Fails To Ignite

1. No DC current. Switch MAIN LINE breaker ON.
2. Low DC no load voltage from xenon power supply. Check no load voltage by holding VOLTAGE switch and pressing "LAMP" switch (or observe digital display). Repair or replace power supply if no load voltage does not reach 140 V.DC.

TROUBLESHOOTING (continued)

Bulb Fails To Ignite (continued)

3. Defective xenon bulb. Check for damaged or scorched electrodes, discolored quartz envelope or end caps. Replace if defective.
4. Faulty igniter. Arc at spark gap should be audible, and arc across bulb electrodes should be visible through arc viewing port. Repair or replace.
5. Incorrect igniter assembly. Consoles with switching power supplies use 39862; consoles with high reactance power supplies require 39865. Check Part Number stamped on igniter case.
6. DC output level too low. Increase power supply to rated bulb current.
7. Faulty automation contact. If lamp ignites by means of the "LAMP" switch, but fails to ignite automatically, check automation controller.
8. Loose or faulty terminal connection. Visually inspect connections, particularly in AC circuit (5 & 6) and all DC connections.
9. Ignition pulse arcing to ground. Dress all igniter and bulb leads away from grounded metal lamphouse components.

Bulb Goes Out During Operation

1. Blocked bulb seal blower intake or defective blower motor. Clean or replace.
2. Air flow switch sticking or faulty. Clean or replace.
3. Exhaust system malfunction. Check for correct exhaust blower operation; unobstructed air flow through ducting.
4. Overheated thermal switch in xenon power supply. Check for unobstructed air flow through power supply; loose DC connection(s).
5. Blower motor overheated, internal thermal switch open. Allow to cool; clean and oil as required.
6. Faulty automation contact. If lamp operates normally in "manual" mode (using "LAMP" switch), check automation controller relay.
7. Faulty xenon bulb. Check for damaged electrodes, darkened envelope, instability in operating current or voltage. Replace if defective.
8. Phase loss or unstable AC source. See xenon power supply manual; Strong switching power supplies feature *Phase Loss Detection* and *Brown-Out Protection* circuits.

Excessive Light Flicker

1. Defective xenon bulb. Check for cracked and/or sagging electrode.
2. Arc stabilization magnet missing or reversed. Replace or correct.
3. Projector shutter mis-timed. See projector manual.
4. Rectifier diode open or shorted (high reactance supply). Replace as required.
5. Excessive ripple in power supply DC output. Consult factory.

TROUBLESHOOTING (continued)

Reduced Light Output

1. Normal bulb aging. Increase current. Do not exceed maximum current rating specified by bulb manufacturer.
2. Defective bulb. Check for discoloration or premature darkening of envelope.
3. Bulb defocused or misaligned.

Noise in Theatre Sound System During Bulb Ignition or Operation

1. Defective RF suppression capacitor on Voltage Divider PCB. Check with capacitor tester and replace if defective.
2. Console or sound system not correctly grounded. Connect to adequate earth ground.

Excessive Heat at Film Trap (Film Burning)

1. Xenon bulb misfocused. Focus bulb for even field using CinemaScope aperture plate; do not hot spot screen center.
2. Dichroic coating on reflector peeled. Replace reflector.
3. Excessive bulb wattage. **DO NOT EXCEED 4500 watts** for 35mm projection. Air or water-cooled 35mm film traps *do not* adequately reduce the *high radiant energy* levels generated by 7000 watt xenon bulbs. Bulb wattages in excess of 4500 watts are for use with 70mm and larger apertures **ONLY**.

NOTICE

The Strong DC Pulse Igniter is a sealed assembly and contains no user serviceable components. The Strong switching-type Xenon Power Supply employs solid state circuitry requiring sophisticated diagnostic equipment not generally available to field service personnel. If an ignition problem in the TROUBLE CHART section is traced to either of these units, contact an authorized Strong International Dealer for further information.

FIGURE 1

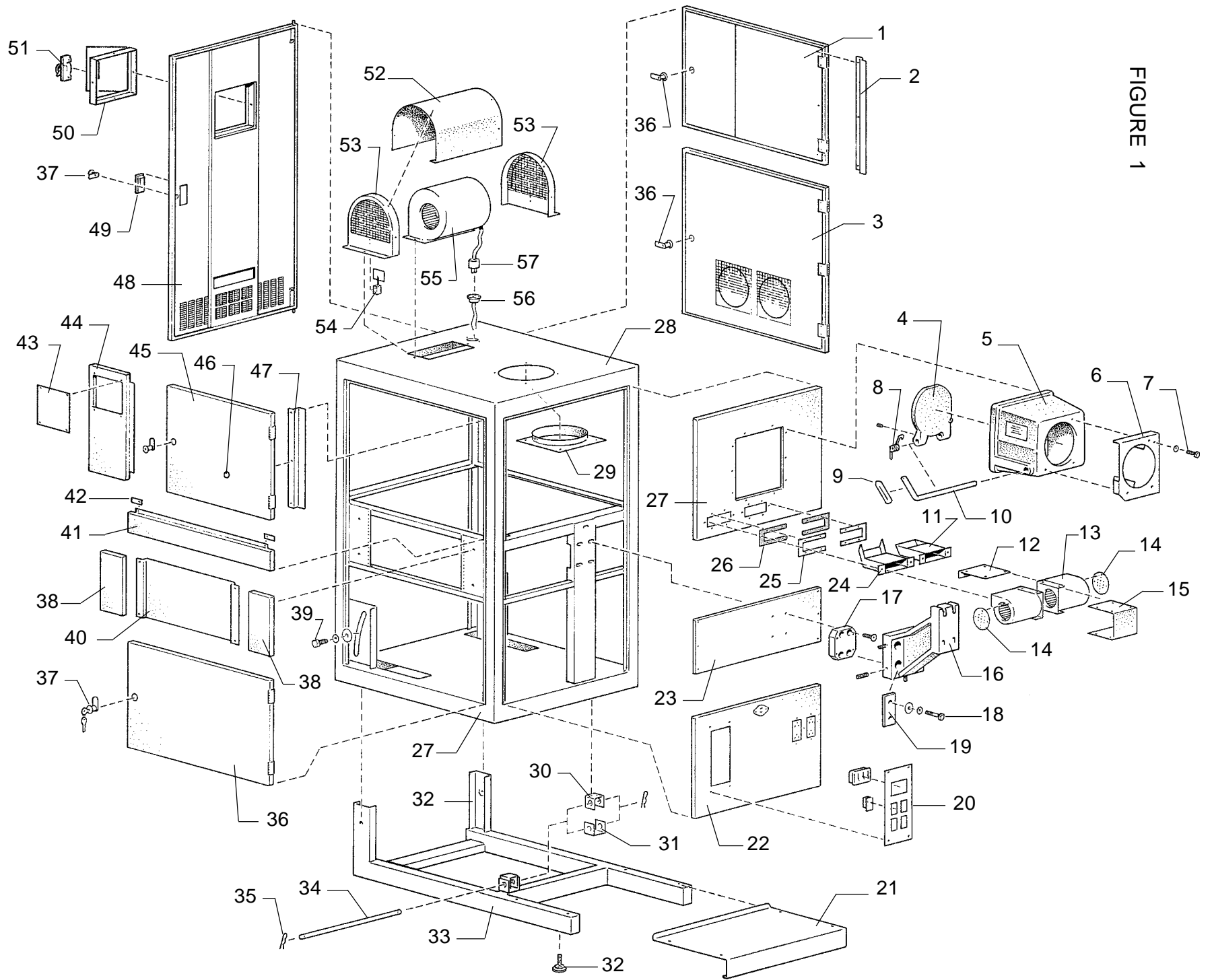

HL2/034

PARTS LIST

Figure 1

<u>Item</u>	<u>Part No.</u>	<u>Description</u>
1	23979	Access Door & Hinge Assembly, Off-Operator Side
-	41-51102	Mounting Screw, 10-32 x 1/2" Bind Head
-	41-35012	Hexnut, 10-32
-	41-70014	Lockwasher, #10
-	41-70003	Flatwasher, #10
2	23938	Light Baffle
-	01748	Mounting Screw, 6-32 x 3/8" Hex Head
3	10512	Side Door & Hinge Assembly, Off-Operator Side (see Item 1 for Hardware)
-	71220	Blower, 6" Round Frame, 115 V.AC, 50/60 Hz.
-	71627	Blower, 6" Round Frame, 230 V.AC, 50/60 Hz. (Export)
		<i>Side Door Blowers required with High Reactance Power Supplies only.</i>
4	81148	Douser Plate Casting
-	81234	Rubber Bumper, Douser Plate
-	81432	Shoulder Screw (attachs Plate to Shaft)
5	71252	Casting, Douser Housing
-	01566	Mounting Screw, 10-24 x 5/16" Pan Head
-	01716	Mounting Screw, 10-24 x 5/8" Pan Head
6	81847	Beam Spread/Heat Filter Holder (optional)
7	00705	Screw, 1/4-20 x 1-1/8" Hex Head
8	81187	Torsion Spring, Douser Shaft
9	45150A	Handle Grip, Douser Shaft
10	81433	Douser Cross Shaft & Handle
11	23953	Reflector Air Duct
12	24367	Motor Mounting Bracket
13	23939	Dual Squirrelcage Blower & Motor
-	31-40002	Twistlock Plug
14	23958	Blower Intake Grille
15	23959	Motor Shield
-	25108	Front Blower Assembly (Items 12-14)
16	71226	Soundhead Mounting Arm
-	01784	Set Screw, Arm Positioning
17	71221	Nut Plate, Mounting Arm
-	41-51348	Mounting Screw, 5/16-18 x 2-1/4" Flat Socket Head
18	41-51149	Bolt, 3/8-16 x 1-1/2" Hex Head
-	00878	Split Lockwasher, 3/8"
-	41-70007	Flatwasher, 3/8"
19	71240	Adjustment Slide Bar
20	24389	Circuit Breaker Panel (less Components)
-	24348	Circuit Breaker, 15 A.
-	24347	Circuit Breaker, 10 A.
-	24345	Circuit Breaker, 5 A.
-	24380	Buss Bar
-	24381	Filler Plug (as req'd.)
-	01307	Panel Mounting Screw, 10-32 x 3/8" Bind Head
-	41-70014	Lockwasher, #10

FIGURE 1 Parts List (continued)

<u>Item</u>	<u>Part No.</u>	<u>Description</u>
21	71331	Cover, Base Legs
-	01307	Mounting Screw, 10-32 x 3/8" Bind Head
22	71155	Lower Front Cover
-	01737	Mounting Screw, 10-32 x 5/8" Hex Head
-	21-40240	Duplex Receptacle, Rectangular (not shown)
23	71225	Mounting Plate, Soundhead Arm
-	41-51223	Screw, 1/4-20 x 1" Socket Head
-	41-35015	Hexnut, 1/4-20
-	00876	Lockwasher, 1/4" Split Ring
24	23950	Bulb Air Duct
25	25162	Gasket Retaining Plate
-	41-51041	Mounting Screw, 6-32 x 3/8" Bind Head
26	25161	Light Gasket, Rubber
27	23947	Front Panel & Heat Shield, Welded Assembly
-	01737	Mounting Screw, 10-32 x 5/8" Hex Head
28	24197	Console Frame, Welded Assembly
29	71728	Exhaust Duct, 8" (200mm)
-	41-51540	Mounting Screw, 8-32 x 3/8" Round Phillips Head, Black Oxide
30	71254	Upper Bracket, Pivot Shaft
-	41-51121	Mounting Screw, 1/4-20 x 5/8" Hex Head
31	71134	Lower Bracket, Pivot Shaft
-	41-51121	Mounting Screw, 1/4-20 x 5/8" Hex Head
32	71184	Leveling Foot
33	71998	Console Base, Welded Assembly
34	71199	Pivot Shaft
35	01783	Hitch Pin, Pivot Shaft
36	71853	Power Supply Access Door & Hinge Assembly
-	41-51102	Mounting Screw, 10-32 x 1/2" Bind Head
-	41-70014	Lockwasher, #10
-	41-70003	Flatwasher, #10
-	41-35012	Hexnut, 10-32
37	71284	Cam Lock & Keys
38	24241	Filler Panel
-	01737	Mounting Screw, 10-32 x 5/8" Hex Head
39	01472	Tilt Lock Screw, 1/2-13 x 1" Hex Head
-	41-70009	Flatwasher, 9/16"
40	24292	Filler Plate, 10.5 x 19"
-	41-51110	Mounting Screw, 10-32 x 1/2" Phillips Truss Head, Black Oxide
41	24112	Cover Panel
42	71260	Mounting Tab
-	41-51	Mounting Screw
43	24249	Control Panel, Digital (see Figure 2)
43	24243	Control Panel, Analog (see Figure 2)
-	41-51414	Mounting Screw, 8-32 x 3/8" Pan Head, Black Oxide
44	24246	Rear Quarter Panel, Welded Assembly
-	01737	Mounting Screw, 10-32 x 5/8" Hex Head

FIGURE 1 Parts List (continued)

<u>Item</u>	<u>Part No.</u>	<u>Description</u>
45	24147	Lamphouse Access Door & Hinge Assembly See Item 1 for Mounting Hardware
46	48930	Arc Viewing Port
47	71204	Light Baffle
-	01748	Mounting Screw, 6-32 x 3/8" Self-Tapping
48	24104	Rear Door, Welded Assembly
49	25214	Door Handle, Recessed
50	24103	Access Door & Frame, Welded Assembly
-	23832	Magnetic Catch (not shown)
-	01748	Mounting Screw, 6-32 x 3/8" Self-Tapping
51	23833	Concealed Pull, Access Door
52	40194	Cover, Top Blower
-	01307	Mounting Screw, 10-32 x 3/8" Bind Head
53	40920	Frame & Grille, Blower Cover
-	01748	Mounting Screw, 6-32 x 3/8" Self-Tapping
54	25200	Air Vane Switch Assembly
-	85109	Switch
-	24419	Air Vane
-	41-51412	Mounting Screw, 6-32 x 1/4" Phillips Head
-	41-70012	Lockwasher, #6
-	41-35005	Hexnut, 6-32
55	25110	Top Blower Assembly, 115 V.AC, 50/60 Hz.
-	25109	Top Blower Assembly, 220 V.AC, 50/60 Hz. (Export)
-	41-51121	Mounting Screw, 1/4-20 x 5/8" Hex Head
56	11-40019	Receptacle, Twistlock Plug
57	31-40002	Twistlock Plug

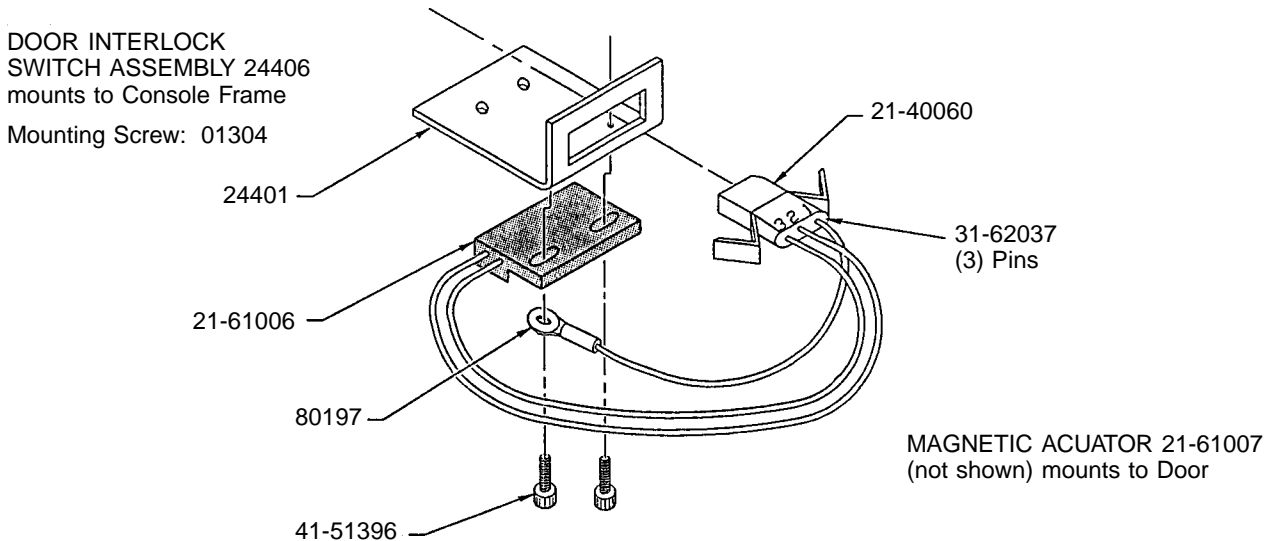

CONTROL PANELS

Digital

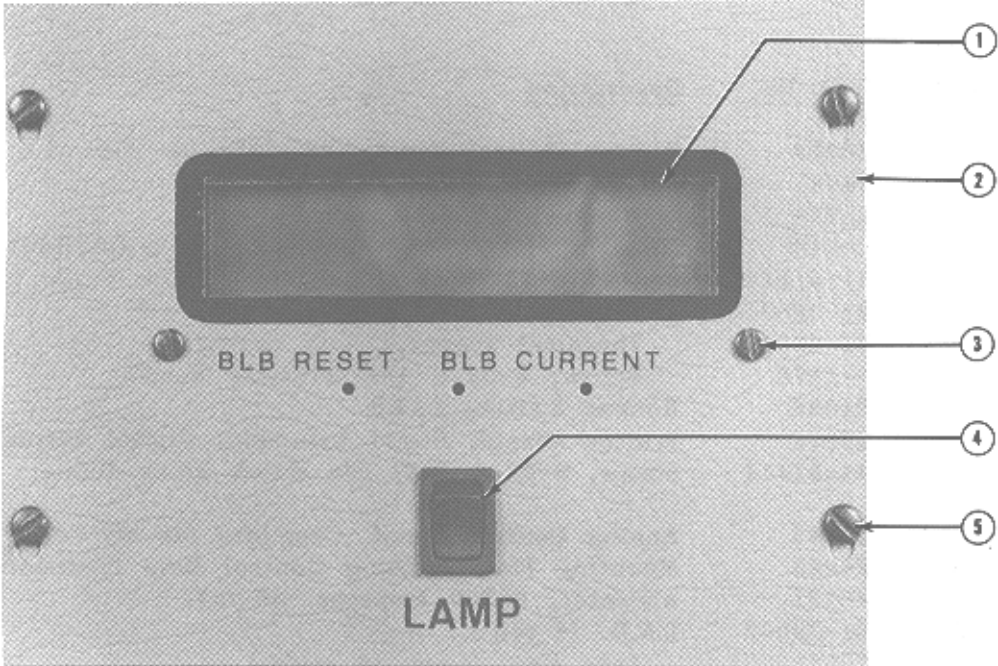

Analog

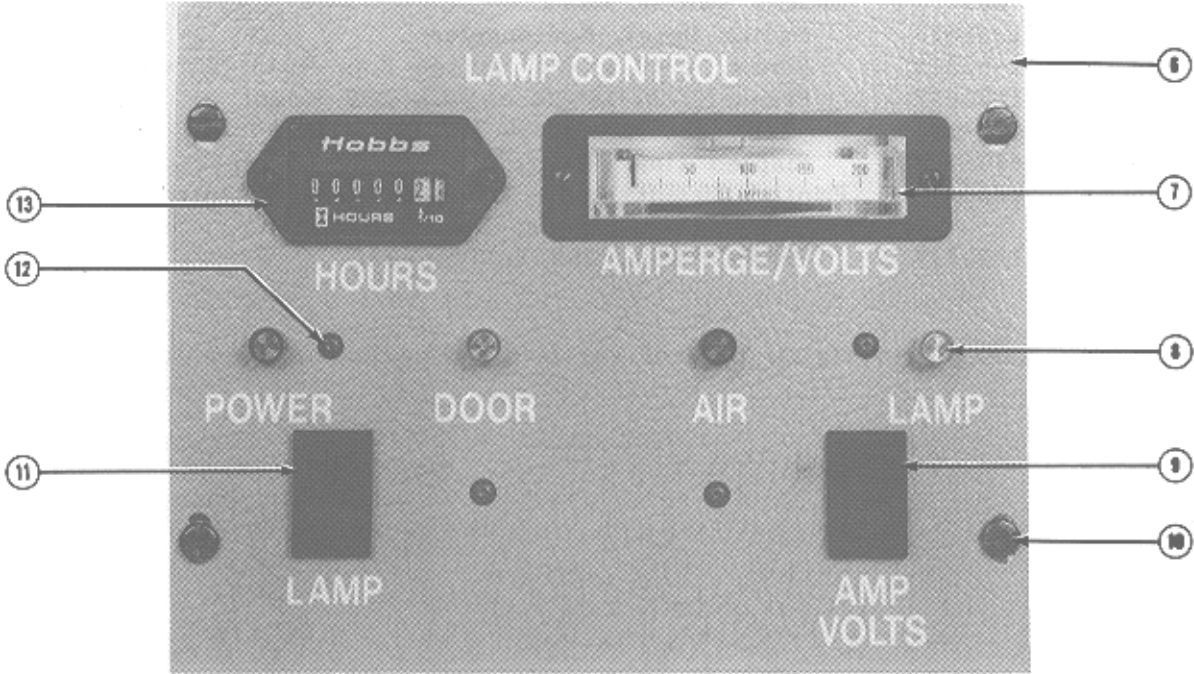

For Position ONLY - Run Halftone Plate!

FIGURE 2

PARTS LIST

Figure 2

<u>Item</u>	<u>Part No.</u>	<u>Description</u>
-	24249	Digital Control Panel , Complete (as shown)
1	24087	L.C.D. Screen, Digital Display
-	24254	Window, L.C.D. Screen
2	24248	Mounting Plate, Digital Display (less Components)
3	41-51412	Screw, 6-32 x 1/4" Pan Head, Black Oxide (2 req'd.)
-	61-98022	Brass Standoff, 1/2" (2 req'd.)
-	61-98023	Threaded Spacer, 1" (2 req'd.)
-	P-1676	Screw, 6-32 x 1/4" Fillister Head
4	24086	Rocker Switch, LAMP
-	23976	Printed Circuit Board Assembly, Digital Display
5	41-51414	Screw, 8-32 x 3/8" Pan Head, Black Oxide
-	24243	Analog Control Panel , Complete (as shown)
6	24245	Mounting Plate, Analog Control (less Components)
7	40191	Ammeter, 0-200 Amperes, 50 mV.
8	81-30002	L.E.D. (4 req'd.)
-	7056-0007	Lens Cap, Green (4 req'd.)
9	23868	Rocker Switch, Momentary; "Volts"
-	51-61015	Switch Bezel, Rectangular
10	41-51414	Screw, 8-32 x 3/8" Pan Head, Black Oxide
11	23869	Rocker Switch, LAMP
-	51-61015	Switch Bezel, Rectangular
12	41-51012	Screw, 4-40 x 1/4" Button Socket Head (8 req'd.)
-	81-56007	Standoff, 11/16" (4 req'd.), PCB Mount
13	2479-1216	Elapsed Time Meter, 60 Hz. (81-32001)
-	2479-1215	Elapsed Time Meter, 50 Hz. (81-32004)
-	24236	Printed Circuit Board Assembly, Analog Control (PCB Assembly includes Items 8, 9, 11)
-	21-21017	Fuse, 3 Amp. 250 V. Type 3AG

NOTE: Analog and Digital Control Panels are Plug-Interchangeable.

LAMPHOUSE ASSEMBLY

FIGURE 3

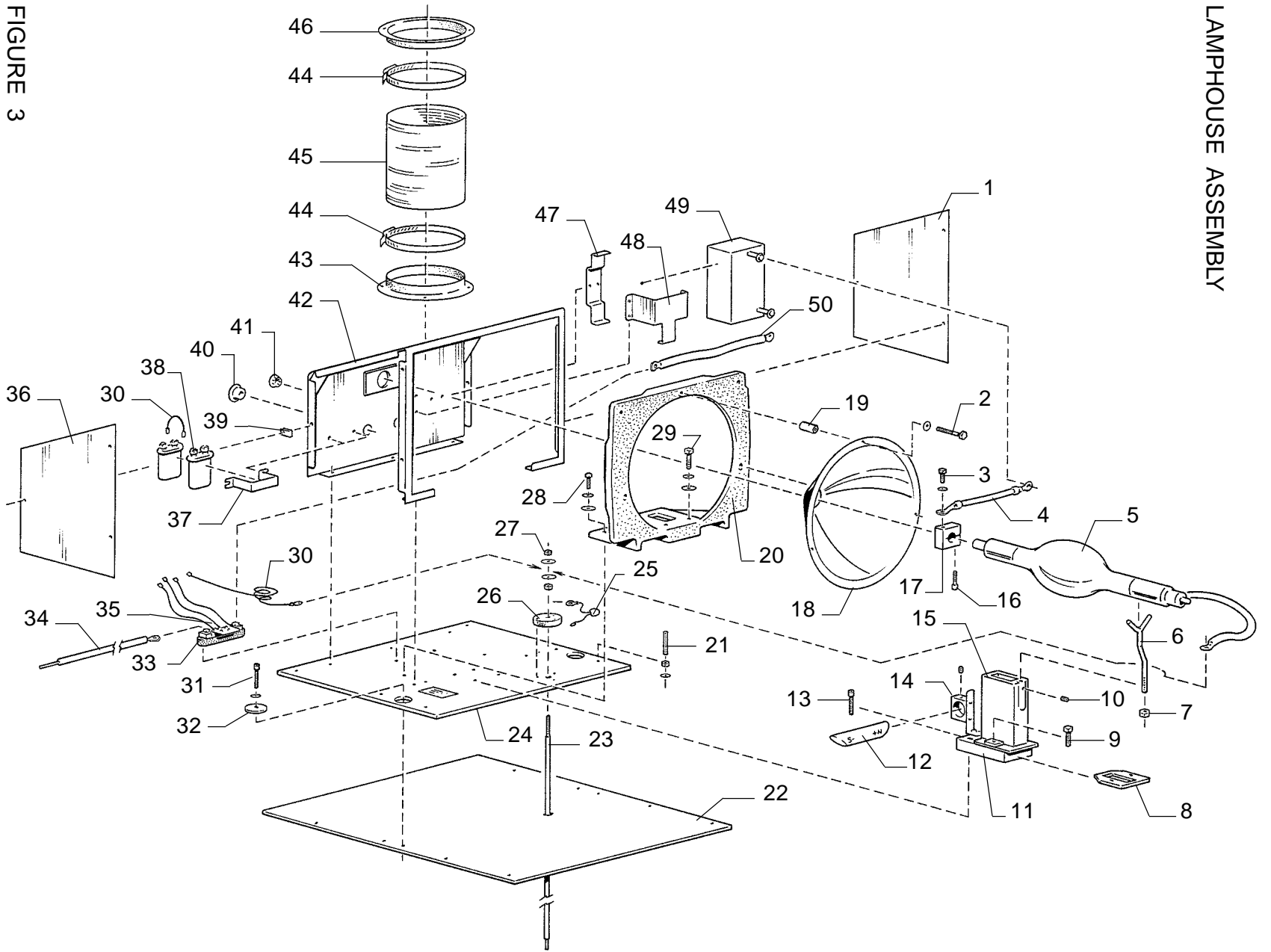

HL2/039

PARTS LIST

Figure 3

<u>Item</u>	<u>Part No.</u>	<u>Description</u>
1	23942	Enclosure Cover Panel, Off-Operator Side
-	31875	Thumb Screw (not shown)
-	01507	Tinnerman Nut (see Item 38)
2	41-51120	Mounting Screw, 1/4-20 x 1-1/2" Socket Head
3	00685	Screw, 1/4-20 x 3/8" Hex Head
-	00876	Lockwasher, 1/4" Split Ring
4	24265	Igniter Lead Assembly
5	---	Xenon Bulb (supplied by Customer)
6	70162	Bulb Support Yoke
7	41-35013	Hexnut, 10-32
8	23980	Fibre Insulator Plate
9	01796	Nylon Screw, 5/16-18 x 3/4" Hex Head
10	41-51443	Set Screw, 8-32 x 1/4"
11	23914	Support Block, Air Duct
12	M15315	Arc Stabilization Magnet
13	01544	Screw, 1/4-20 x 1" Socket Head
14	81137	Magnet Clamp
-	41-51443	Set Screw, 8-32 x 1/4"
-	71424	"L" Bracket, Magnet Clamp
-	01304	Mounting Screw, 8-32 x 5/16" Pan Head
15	40107	Air Duct/Bulb Support Casting
16	01532	Clamping Screw, 8-32 x 7/8" Socket Head
17	40965	Negative Contact Clamp, 4-7 kW (8mm Bulb Pin)
17	24430	Negative Contact Clamp, 5 kW Osram (18mm Bulb Pin)
17	40966	Negative Contact Clamp, 3-7 kW (13mm Bulb Pin)
17	65845	Negative Contact Clamp, 2 kW and below (12mm Bulbm Pin)
18	23754	Flanged Reflector, 15" Dichoric Coated
19	23981	Spacer, Reflector Mount
20	25104	Reflector Bulkhead Casting
21	41-51470	Burner Plate Adjusting Screw, 5/16-18 x 1-3/4" Headless
-	41-35018	Lock Nut, 5/16-18 Hex
22	23940	Lamphouse Sub Plate, 1/8" Steel
-	41-51102	Mounting Screw, 10-32 x 1/2" Bind Head
-	41-35012	Hexnut, 10-32
23	24262	Positive Lead Assembly, Feed-Through
24	23941	Lamphouse Burner Plate, 1/4" Steel
25	25218	Noise Filter Capacitor
26	81301	Binding Post Insulator, Phenolic
-	00385	Mounting Screw, 10-24 x 1/2" Fillister Head
27	01678	Hexnut, 3/8-16 Brass
-	00839	Flatwasher, 3/8" Brass

FIGURE 3 Parts List (continued)

<u>Item</u>	<u>Part No.</u>	<u>Description</u>
28	41-51146	Bulkhead Mounting Screw, 3/8-16 x 3/4" Hex Head
-	00878	Lockwasher, 3/8" Split Ring
-	00839	Flatwasher, 3/8"
29	41-51150	Bulkhead Mounting Screw, 3/8-16 x 1-3/4" Hex Head
-	00878	Lockwasher, 3/8" Split Ring
-	00839	Flatwasher, 3/8"
30	24280	Capacitor Wire Harness
31	01778	Tie-Down Screw, 5/16-18 x 1-3/4" Socket Head
32	23912	Fender Washer
33	81247	Shunt (R1), 200 A. 50 mV.
-	00389	Mounting Screw, 10-24 x 3/4" Fillister Head
34	25206	Negative Lead, Power Supply to Shunt
35	24275	Voltage Divider PC Board Assembly
36	23943	Enclosure Cover Panel, Operator Side
-	31875	Thumb Screw (not shown)
-	01507	Tinnerman Nut, #10 (see Item 39)
37	76208	Capacitor Clamping Strap
-	01311	Mounting Screw, 8-32 x 3/8" Bind Head
38	76323	RF Suppression Capacitor
39	01507	Tinnerman Nut, #10
40		Grommet
41		Hole Plug
42	23960	Enclosure Assembly, Bulb Compartment
-	01566	Mounting Screw, 10-24 x 5/16" Bind Head
-	41-70014	Lockwasher, #10
43	23778	Lower Hose Mount
-	01311	Mounting Screw, 8-32 x 3/8" Bind Head
-	41-70013	Lockwasher, #8
-	41-35008	Hexnut, 8-32
44	23830	Hose Clamp
45	23829	Fibreglass Hose, 9" Diameter
46	23778	Upper Hose Mount
-	00685	Mounting Screw, 1/4-20 x 3/8" Hex Head
-	00876	Lockwasher, 1/4" Split Ring
-	00805	Hexnut, 1/4-20
47	23790	Igniter Mounting Bracket, Inner
-	00687	Mounting Screw, 1/4-20 x 1/2" Hex Head
-	00876	Lockwasher, 1/4" Split Ring
-	00805	Hexnut, 1/4-20
48	23791	Igniter Mounting Bracket, Outer
-	00687	Mounting Screw, 1/4-20 x 1/2" Hex Head
-	00876	Lockwasher, 1/4" Split Ring
-	00805	Hexnut, 1/4-20
49	39862	DC Pulse Igniter (with Switching Power Supply)
49	39865	DC Pulse Igniter (with High Reactance Power Supply)
50	24265	Lead Assembly, Shunt to Igniter

65827 BULB ADJUSTMENT MECHANISM

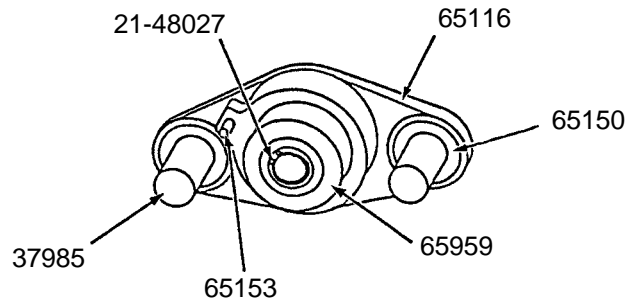

37985	Thumb Screw (2 req'd.)
15010	Compression Spring (2 req'd.)
65116	Casting, Adjustment Mechanism
65150	Fender Washer (2 req'd.)
65153	Focus Lockscrew
65154	Nylon Locking Ball
65959	Focus Screw & Bearing Assembly
21-48027	Snap Ring, Collet Retaining

REAR BULB SUPPORT COLLET ASSEMBLY

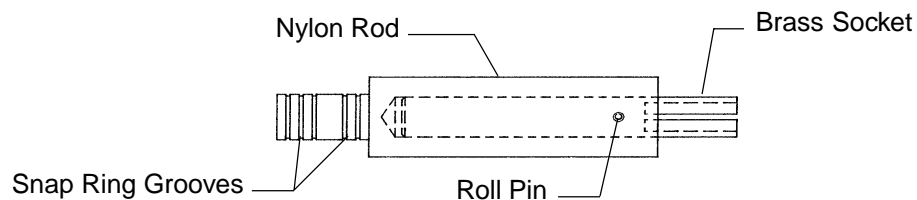

<u>Bulb Wattage</u>	<u>Collet Part No.</u>	<u>Overall Length</u>	<u>Socket Diameter</u>
2000 & below	24179	5-3/8" (13.65cm)	.475" (12mm)
2000, 3000 "HS"	24201	5-5/16" (13.50cm)	.312" (8mm)
2500 "HS"	24201	5-5/16" (13.50cm)	.312" (8mm)
3000	24180	4-3/8" (11.11cm)	.551" (14mm)
4000-4500 "HS"	24181	4-1/4" (10.80cm)	.312" (8mm)
5000	24433*	4-5/8" (11.75cm)	.710" (18mm)
7000 "HS"	24181	4-1/4" (10.80cm)	.312" (8mm)
3000-7000 "H/VC"	24180	4-3/8" (11.11cm)	.551" (14mm)

* Osram XBO5000W/H OFR; other types, consult Factory

Bulb Adapters required for 1000 and 1600 watt bulbs only. See preceding HIGHLIGHT II XENON BULBS section for adapter Part Numbers.

INSTRUCTION MANUAL

STRONG HIGHLIGHT II

Xenon Projection Console

Type 72000

Rev. 4/98



**STRONG
INTERNATIONAL**

a division of Ballantyne of Omaha, Inc.
4350 McKinley Street
Omaha, Nebraska 68112 USA
Tel 402/453-4444 • Fax 402/453-7238

